

Design and Development Of 3D Sand Mold Printer For Rapid Casting



Author

ARSLAN ASGHAR

Registration Number

00000171911

Supervisor

DR. MUSHTAQ KHAN

DEPARTMENT OF DESIGN AND MANUFACTURING ENGINEERING

SCHOOL OF MECHANICAL & MANUFACTURING ENGINEERING

NATIONAL UNIVERSITY OF SCIENCES AND TECHNOLOGY

ISLAMABAD

JULY 2019

Design and Development of 3D Sand Mold Printer for Rapid Casting

Author

ARSLAN ASGHAR

Registration Number

00000171911

A thesis submitted in partial fulfillment of the requirements for the degree of
Masters in Design and Manufacturing Engineering

Thesis Supervisor:

DR. MUSHTAQ KHAN

Thesis Supervisor's Signature: _____

DEPARTMENT OF DESIGN AND MANUFACTURING ENGINEERING
SCHOOL OF MECHANICAL & MANUFACTURING ENGINEERING
NATIONAL UNIVERSITY OF SCIENCES AND TECHNOLOGY,
ISLAMABAD

JULY, 2019

Declaration

I certify that this research work titled “*Design and Development of 3D Sand Mold Printer For Rapid Casting*” is my own work. The work has not been presented elsewhere for assessment. The material that has been used from other sources it has been properly acknowledged / referred.

Signature of Student

ARSLAN ASGHAR

00000171911

Thesis Acceptance Certificate

It is certified that the final copy of MS Thesis written by Arslan Asghar (Registration No. 00000171911), of Department of Design & Manufacturing (SMME) has been vetted by undersigned, found complete in all respects as per NUST statutes / regulations, is free from plagiarism, errors and mistakes and is accepted as a partial fulfillment for award of MS Degree. It is further certified that necessary amendments as pointed out by GEC members of the scholar have also been incorporated in this dissertation.

Signature: _____

Name of Supervisor: Dr. Mushtaq Khan

Date: _____

Signature (HOD): _____

Date: _____

Signature (Principal): _____

Date: _____

National University of Sciences & Technology

MASTER THESIS WORK

We hereby recommend that the dissertation prepared under our supervision by: **Arslan Asghar (Registration No. 00000171911)** Titled: Design & Development of a 3D Sand Mold Printer for Rapid Casting be accepted in partial fulfillment of the requirements for the award of Master's in Design & Manufacturing degree and awarded grade _____.

Examination Committee Members

**ORIGINAL TH-4 FORMS WILL BE PASTED HERE THAT
WERE BEEN SIGNED BY SUPERVISOR AND GEC COMITTEE
MEMBERS ON DAY OF DEFENSE PRESENTATION**

Plagiarism Certificate (Turnitin Report)

It is certified that MS Thesis Titled “*Design and Development of 3D Sand Mold Printer For Rapid Casting*” by Arslan Asghar has been examined by us. We undertake the following:

- a) The thesis has significant new work/knowledge as compared already published or are under consideration to be published elsewhere. No sentence, equation, diagram, table, paragraph or section has been copied verbatim from previous work unless it is placed under quotation marks and duly referenced.
- b) The work presented is original and own work of the author (i.e. there is no plagiarism). No ideas, processes, results, or words of others have been presented as an Author own work.
- c) There is no fabrication of data or results which have been compiled/analyzed.
- d) There is no falsification by manipulating research materials, equipment or processes, or changing or omitting data or results such that the research is not accurately represented in the research record.
- e) The thesis has been checked for plagiarism using TURNITIN (copy of originality report attached) and found within the limits as per HEC plagiarism Policy and instructions issued from time to time. Turnitin report endorsed by Supervisor is attached.

Signature of Student

ARSLAN ASGHAR

Registration Number

00000171911

Signature of Supervisor

Dr. Mushtaq Khan

Copyright Statement

- Copyright in text of this thesis rests with the student author. Copies (by any process) either in full, or of extracts, may be made only in accordance with instructions given by the author and lodged in the Library of NUST School of Mechanical & Manufacturing Engineering (SMME). Details may be obtained by the Librarian. This page must form part of any such copies made. Further copies (by any process) may not be made without the permission (in writing) of the author.
- The ownership of any intellectual property rights which may be described in this thesis is vested in NUST School of Mechanical & Manufacturing Engineering, subject to any prior agreement to the contrary, and may not be made available for use by third parties without the written permission of the SMME, which will prescribe the terms and conditions of any such agreement.
- Further information on the conditions under which disclosures and exploitation may take place is available from the Library of NUST School of Mechanical & Manufacturing Engineering, Islamabad.

Acknowledgements

Special thanks to ALLAH ALMIGHTY for providing me with this opportunity and granting me with the strength and skills necessary for this task. Indeed, nothing is possible without his divine decree. I could have done nothing without his priceless help and guidance.

I would like to show gratitude for the encouragement and support of my Supervisor Dr. Mushtaq Khan and my Co-Supervisor Dr. Hussain Imran. It would have been impossible to complete my thesis without the continuous support of my respected supervisor Dr. Mushtaq Khan.

I would like to thank my teachers who tutored us with dedication and commitment at ‘NUST University’. I would like to acknowledge the support of Department of Manufacturing and Design Engineering for providing us adequate resources and workspace within the premises of university to accomplish our task efficiently. I would also like to pay special thanks to my class fellow for his tremendous support and cooperation.

I would also like to pay special thanks to the entire staff of the Manufacturing Resource Center (MRC) and the CNC Lab who have been really helpful. Without their cooperation and help, the fabrication for the project would not have been possible.

Last but not least I am grateful to my family who has supported me both morally and financially at every step. Special dedication to my exceptional parents and adored siblings, whom tremendous support and cooperation led me to this wonderful accomplishment.

Abstract

3D printing is one of “Additive Manufacturing” technique that has been defined as “the process of joining materials to make parts from 3D model data, usually layer upon layer, as opposed to subtractive manufacturing and formative manufacturing methodologies”. The process is used for rapid casting and can be used for direct printing of sand molds. It holds quite a promise to reduce the lead times of cast parts since it can create difficult and exact sand cores and molds directly from CAD data, thereby reducing the need for a physical pattern. Research had been carried out to determine how the locally available/used sands and binders affect the properties of the 3D printed mold. An experimental scale lab setup for 3D printing sand molds was also developed which had made use of inkjet printing technology to spray the binder on the sand layers. The process was started with distributing a fine layer of sand, pre-mixed with the activator, and followed by spraying binder in the selected area of the deposited sand layer. Bonding reactions took place that made the sand particles stick together only within the region where the binder was sprayed. The process was repeated as the platform moves downward by a set distance until all of the layers of the part are completely printed and a final sand layer is spread. Finally, the mold produced was tested for determining the relationships between the various parameters and the properties of the 3-D printed mold. Piezoelectric Jet Head was also designed and manufactured in order to study the droplet dispersion of binder that is jetted by head.

Table of Contents

Declaration	i
Thesis Acceptance Certificate	ii
FORM TH-4	iii
Plagiarism Certificate (Turnitin Report)	iv
Copyright Statement	v
Acknowledgements	vi
Abstract	vii
List of Figures	x
CHAPTER 1: INTRODUCTION	1
1.1 Casting Process – An Overview	1
1.2 Problem Statement	3
1.3 Objectives	4
1.4 Breakdown of Thesis Report	4
CHAPTER 2: LITERATURE REVIEW	5
2.1 Additive Manufacturing	5
2.1.1 Advantages	5
2.1.2 Disadvantages	6
2.1.3 Types of additive manufacturing	7
2.2 Sand casting.....	9
2.2.1 Types of sand casting	10
2.3 Local Visits & Surveys	10
Small Scale Local Foundries.....	10
KSB Pumps (Hassan Abdaal):	11
Excel Engineering (Lahore):	11
2.4 3DP of Sand Molds Using Additive Manufacturing.....	13
CHAPTER 3: METHODOLOGY	18
3.1 Selection of Binder.....	18
3.2 Selection of Print Head	20
3.2.1 Piezoelectric Print Heads:	20
3.2.2 Thermal Inkjet Print Heads:	21

3.3 Initial Testing	21
3.4 Design and Development	25
3.4.1 Sand Beds Mechanism	25
3.4.2 Base frame	27
3.4.3 Control Circuit	27
3.4.4 Recoater.....	28
3.4.5 Binder Jetting Mechanism.....	30
3.4.6 Piezo Electric Jet Head.....	33
CHAPTER 4: TESTING & RESULTS	35
4.1 Operating Instructions	35
4.2 Testing & Results.....	36
CHAPTER 5: CONCLUSION & FUTURE WORK.....	39
5.1 Conclusion.....	39
5.2 Recommendations for Future work.....	40
APPENDIX A	42
APPENDIX B	45
REFERENCES.....	48

List of Figures

<i>Figure 1 Types Of Casting</i>	2
<i>Figure 2 Growing trend in the number of scientific research publications on additive manufacturing and 3D sand mold printing</i>	6
<i>Figure 3 Stereo lithographic Process</i>	7
<i>Figure 4 Fused Deposition Modeling Process</i>	7
<i>Figure 5 Selective Laser Sintering Process</i>	8
<i>Figure 6 Powder Bed Binder Jetting Process</i>	9
Figure 7 ExOne's S-MAX 3D Sand Mold Printer	13
Figure 8 Powder Densification Zone	15
Figure 9 Effect of layer thickness on RD in powder densification zone	16
Figure 10 RD of new compacted powder layer with respect to layer thickness	16
<i>Figure 11 Difference between organic and inorganic binder processes</i>	18
<i>Figure 12 Piezoelectric Print Head Working Mechanism</i>	20
<i>Figure 13 Thermal Print Head Working Mechanism</i>	21
<i>Figure 14 EPSON Stylus S22 Printer</i>	21
<i>Figure 15 Initial Test Specimens Using Traditional Ramming Method</i>	23
Figure 16 Initial Test Specimens Using Manual Layer by Layer Deposition	23
<i>Figure 17 Complete 3D View of Sand Beds</i>	26
<i>Figure 18 Rendered 3D Model of Support Frame</i>	27
<i>Figure 19 L298N Motor Driver Pinout Diagram</i>	27
<i>Figure 20 Wired Configuration For Controlling Sand Beds</i>	28
<i>Figure 21 Rendered 3D Model of Recoater</i>	29
<i>Figure 22 Recoater Control Circuit Wiring</i>	29
<i>Figure 23</i> Assembly (Motor / Encoder / Roller)	30
Figure 24 Print Mount Control Circuit Wiring	32
<i>Figure 25 Rendered 3D Model of Final Assembly</i>	35
<i>Figure 26 3D Printed Sand Mold Sample</i>	38
<i>Figure 27 Developed 3D Sand Mold Printer Setup</i>	39
<i>Figure 28 End Shooter VS Xaar's Hybrid Side Shooter Technology</i>	41

List of Tables

<i>Table 1 Binders, properties and applications of some of the 3D printed sand molds</i>	14
<i>Table 2 Initial Test Results for Resin / Catalyst Ratios</i>	22
<i>Table 3 Initial Test Results for Assumed 160 um Layer Thickness</i>	24
<i>Table 4 Brief Summary of Testing and Results</i>	36

CHAPTER 1: INTRODUCTION

Manufacturing process is a transformation of raw material into a final product. It must include the design of product and the material specification from which we aim to make the final product. It contains number of steps like literature review, product design, testing and simulations of design product and then manufacturing begins. Casting is one of the manufacturing processes that deals with liquid material poured into hollow cavity of specific shape and then it is solidified. The solidified part in this process is known as casting that is merely broken down to get required mold. It is a time consuming process, it may take hours of effort yet leaving behind chances of failure. Casting process is best used in industry where you need same type of product in huge numbers. In other words it is best suited for batch production. One of the drawbacks of casting process is that it is not at all flexible in design perspective.

The two most intense requirements which are required for enhanced industrial productivity and competitiveness are the reduction in the required time of manufacturing products and the flexible design of manufactured products in small scale quantities. This requires development of comparatively shorter operation cycles and lead time. Rapid Prototyping reduces these variables and allows for development of various manufacturing methods to bring about innovation. It not only reduces production time but also allows you to flexibly change your design for better and efficient product depending upon customer needs.

Rapid Prototyping are the techniques that employ computer aided design software to construct a part or assembly in short time. The time for fabrication and to develop necessary tooling (e.g. dies) greatly affects the manufacturing process efficiency and productivity. Tooling serves as a gating item for costs related to manufacturing. These are a major factor in determining the batch size for any process. Owing to these factors, rapid prototyping by 3D printing helps to eliminate the need of tooling. 3D printing technology not only reduces the overall time of process but also allow you to make complex molds with flexible design changes.

1.1 Casting Process – An Overview

Casting is process that deals with liquid material poured into hollow cavity of specific shape and then it is solidified. The solidified part in this process is known as casting that is merely broken

down to get required mold. Casting materials are usually metals or different cold setting materials that cure after mixing two or more components together; examples are epoxy, concrete, plaster and clay. Casting is most often used for making complex shapes that would be otherwise difficult or too expensive to make by other methods.

There are many types of casting techniques such as:

- i. **Investment Casting:** Investment casting as referred to as lost-wax casting is used to produce high quality castings. It derives its name from the fact that the pattern is invested or surrounded with a refractory coating as is suitable for repeatable production of net shape intricate components.
- ii. **Continuous Casting:** It is a refinement of the metal casting process for the continuous high-volume production of constant cross-section metal parts. It allows lower-cost production of metal sections with better quality due to standardized production of product.
- iii. **Centrifugal Casting:** It is the metal casting process in which molten metal is poured into a permanent mold as it spins at high speeds around its axis.
- iv. **Sand Casting:** It is the metal casting process characterized by using sand as the mold material.
- v. **Permanent Mold Casting:** It is the metal casting process in which reusable molds, usually made from metal, are used. It is typically used for the high volume production of simple metal parts.

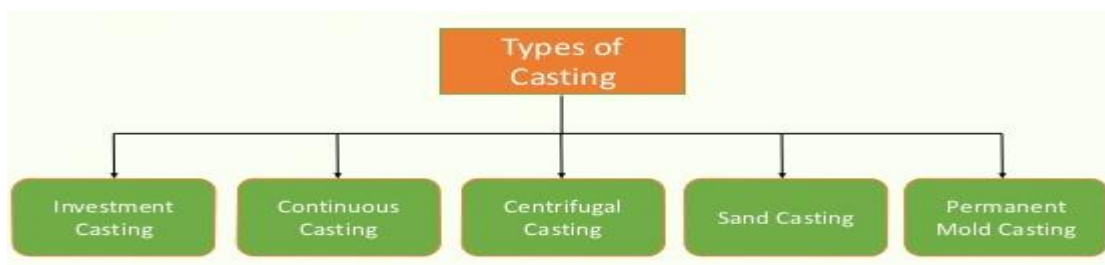

Figure 1 Types Of Casting

Out of these sand casting is one of the most popular and simplest types of casting and has been used for centuries as it allows for smaller batches than permanent mold casting at a very reasonable cost. Based on the type of sand and binding agents used, sand casting is further divided into green sand molding, dry sand molding, no bake sand molding, cold box molding etc.

1.2 Problem Statement

In industrial processes lead time is the key to success. Such processes that have minimum lead time can make a successful reputation in contrast to those having time consuming processes. Every industry lay focus to reduce lead time to increase its productivity and competitiveness. For sand casting, the traditional process begins with manufacturing a physical pattern which is then used to develop a mold. This process however may require a lead time of days, or even weeks sometimes, depending on the complexity of the part to be cast.

Additive Manufacturing, also known as 3D printing, is one of the best solutions for reducing lead time. The technique in principle joins materials to make parts from 3D model data, usually layer upon layer, as opposed to subtractive manufacturing. The process has been used for rapid prototyping, it can also be used for direct printing of sand molds[1]. It holds quite a promise to reduce the lead times of cast parts since it can create complex and accurate sand cores and molds layer by layer directly from computer aided design (CAD) data in a short period of time, thereby eliminating the need for a physical pattern. The processes that are capable of producing sand molds and cores include laser sintering and 3 dimensional printing (3DP), with the latter additive manufacturing process growing in dominance over the former. 3D printing of sand molds by binder jetting technology for rapid casting plays a vital role in providing a better value for orthodox casting industry by producing quality sand molds economically. The parts of the mold assembly can be manufactured by precisely controlling the process parameters and the gas producible binders within the printed mold. A variety of powders, of different particle size or shape, and bonding materials can be used and a functional mold can be manufactured with the required mold properties such as gas permeability, strength, and heat absorption characteristics [2]. This process has high success rate of quality castings with an optimized design for weight reduction.

The importance of 3D printing to produce complex sand molds has increased substantially in the last two decades as casting companies are starting to buy large scale commercial 3D sand mold printers. Confined data is available understand the relationship between the characteristics of the printed mold, the materials used, and the processing parameters for making the mold. Most of the material supply is controlled by machine manufacturers and thus it is difficult for academics to experiment with different materials and to determine their properties. Furthermore, most works have focused on the printers which use powder of plaster-ceramic composition. Other systems

using various sand (e.g. Chromites, Silica, Zircon, or Ceramic Beads) - binder (furan or phenol) - catalyst systems may provide better properties, especially due to the lower binder content than the earlier system [1].

1.3 Objectives

Main aim of this project to build a prototype of 3D sand mold printer that will use layer by layer deposition and drop jet technology. Following are the objectives of research that are mainly covered in this thesis.

- To study the existing procedures used for the production of sand molds in the local foundry.
- To review the literature available related to the 3D printing of sand molds & to obtain the contemporary knowledge about the different mechanisms used.
- To find and select suitable binders/catalyst for the working prototype.
- To design and develop a sand layer deposition platform & compaction mechanism.
- To reverse engineer an existing inkjet printer for binder dispersion.
- To propose and design a substitute piezo electric jetting head if printer head.
- To determine and recommend future work.

1.4 Breakdown of Thesis Report

This thesis report consists of a total of five chapters. In chapter 1, an overview of casting, the research problem and objective of the research is presented. Chapter 2 discuss the different types of sand molds, the different additive manufacturing technologies and the relevant literature available for the 3D printing of sand molds. The chapter also discusses the findings from visits conducted to the local foundries. Chapter 3 covers the methodology for the selection of materials, proof of concept and the development of the lab scale working prototype. Chapter 4 discusses the results obtained from the testing of the developed setup while the final chapter, chapter 5 concludes the research and recommends future work.

CHAPTER 2: LITERATURE REVIEW

2.1 Additive Manufacturing

Additive Manufacturing is a term which refers to a group of production techniques used to fabricate a physical part or assembly by depositing material drop by drop or layer by layer as opposed to subtracting material using three dimensional computer aided design (CAD) data. The geometrical CAD model is sliced into layers and a single two dimensional layer is deposited in the specified shape of the of the part model. Continuous deposition of layers one after another in the end results in the production of a 3 dimensional part with the required geometry.

Like every other technology additive manufacturing has its strengths and its weaknesses and is not always the right choice. It has distinct pros and cons and careful consideration should be done to decide if additive manufacturing is the best process for the required product. Following are some of the prominent advantages and disadvantages of additive manufacturing.

2.1.1 Advantages

- i. **Free complexity:** It actually costs less to print a complex part instead of a simple cube of the same size. The more complex the faster and cheaper it can be made through additive manufacturing.
- ii. **Easy revision:** In traditional manufacturing, modifying a design during production can lead to significant cost increases or time delays as tooling on a production line is changed out. In additive manufacturing parts can be modified on the original CAD file in seconds, and reprinted without complicated tooling changes
- iii. **Reduced assembly components:** Moving parts can be printed in directly into the product which can significantly reduce the quantity of components in the assembly.
- iv. **Reduced lead time:** Prototypes can be printed with a 3-D printer immediately after finishing the part's stereo lithography (STL) file. As soon as the printing is done the parts can undergo testing rather than waiting for weeks or months for a prototype or part to come in.
- v. **Reduction in weight:** Additive manufacturing systems can produce structures with higher strength-to-weight ratio as compared to completely solid structures.

- vi. **Lower wastages:** rather than producing an end product by taking material away, additive manufacturing adds to it instead leading to lower material wastages (if any).
- vii. **Lower energy usage:** As compared with traditional manufacturing processes, additive manufacturing can significantly reduce energy usage by using less material and eliminating the steps from the production process.

2.1.2 Disadvantages

- i. **Slow build rates:** Additive manufacturing processes usually have slow build rates as compared to traditional techniques.
- ii. **Poor quality:** The surface finish and dimensional accuracy may be of a lower quality as opposed to other manufacturing techniques and may require some post processing.
- iii. **Limited size / volume:** The products size / volume is limited to the build area of the machine. While larger machines are available, they tend to be quite a bit pricey.
- iv. **Poor mechanical properties:** The end products may have poor mechanical properties and defects because of the layering and multiple interfaces.

While the process of additive manufacturing has been used for rapid prototyping, its application in the field of manufacturing of sand molds for direct casting is rather new and unexplored. Fig-2 shows the increasing trend of the research and publications in the field of additive manufacturing as well as 3D sand mold printing

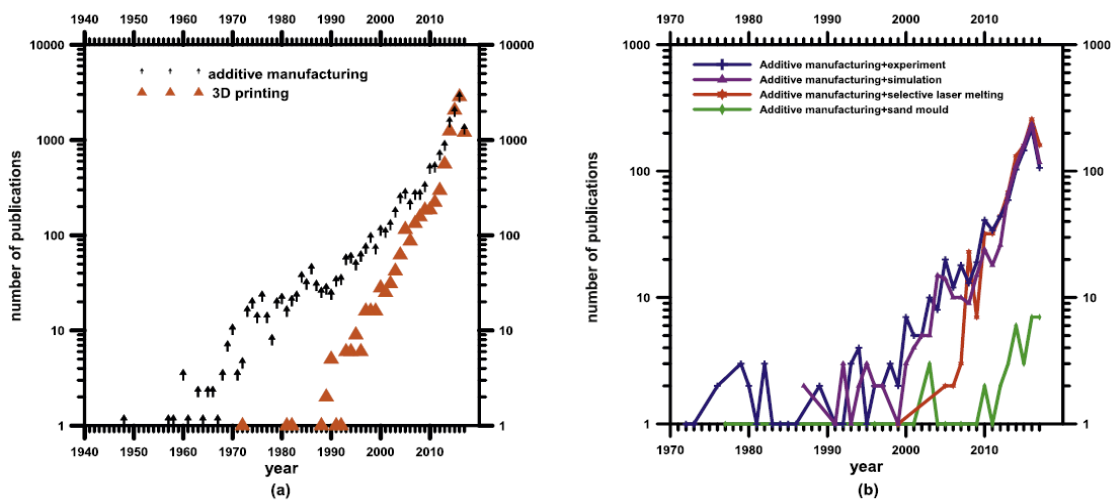

Figure 2 Growing trend in the number of scientific research publications on additive manufacturing and 3D sand mold printing

2.1.3 Types of additive manufacturing

There are various additive manufacturing methods that are being used by the industries to construct parts or geometries. Some of the most widely known are discussed below [3];

- i. **Stereo lithographic:** Also known as VAT photo-polymerization and is a laser-based technology that uses an ultraviolet (UV) light is to cure or harden the resin corresponding to a cross section of the product, whilst a platform moves the object being made downwards after each new layer is cured [4].

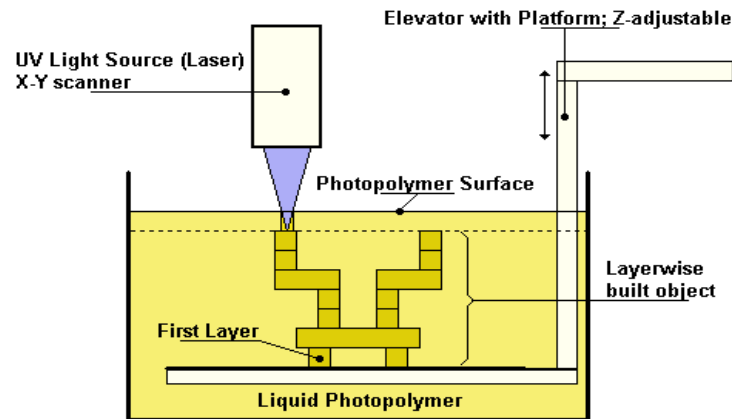

Figure 3 Stereo lithographic Process

- ii. **Fused Deposition Modeling:** It is the most recognizable printing method in which heated material is extruded through a nozzle and onto a build plate. The nozzle continuously moves around, extruding the melted material at a precise location, where it instantly cools and hardens. Layer by layer the part builds up [5].

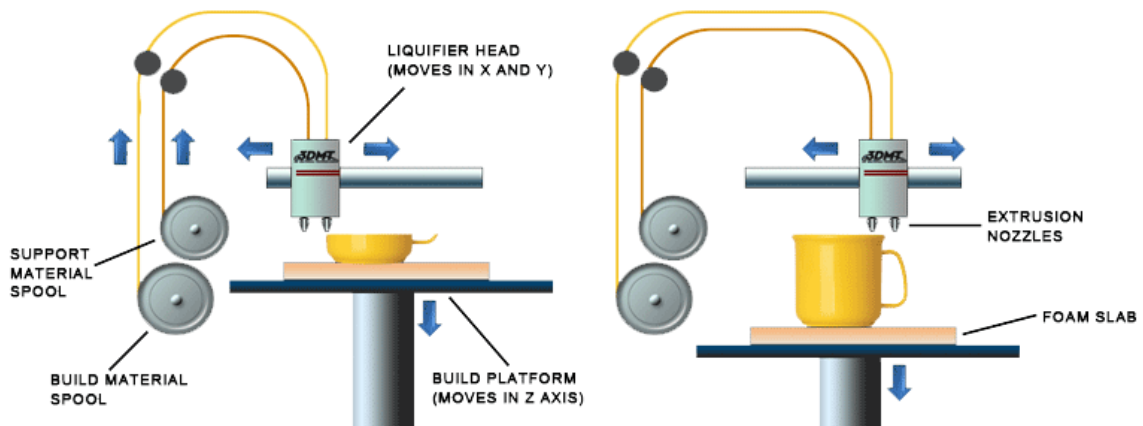

Figure 4 Fused Deposition Modeling Process

- iii. **Selective Laser Melting:** Selective laser melting is an additive manufacturing process that works on the principle of melting and fusing powders through a laser. The usage of the laser ensures that the printed part is in high accordance with the CAD model and has high surface finish and accuracy. The costs however associated for setup and the fabrication of the parts is considerably high. It is used in the casting industry to produce sand or ceramic molds for castings that give high porosity and strength.

- iv. **Selective Laser Sintering:** The process is almost similar to selective laser melting in basic concept. The slight difference is that the powder isn't melted but sintered giving rise to differing properties. The process never actually consolidates the material; instead, the laser simply allows the particles to merge unlike melting which actually creates a pool where the materials can consolidate before reforming and hardening to create a new solid structure.

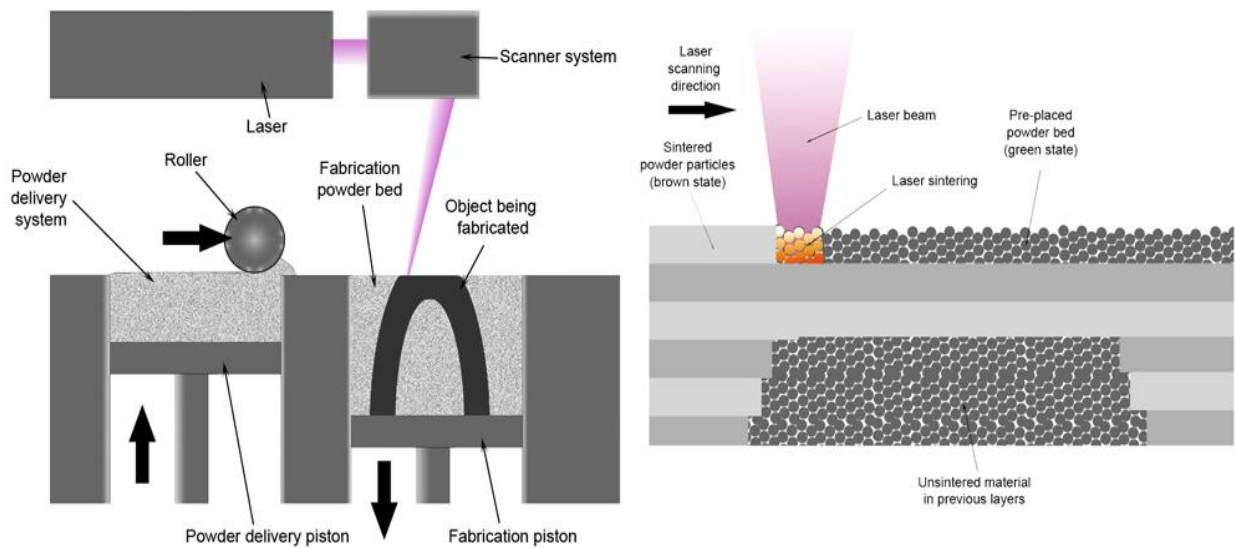

Figure 5 Selective Laser Sintering Process

- v. **Powder Bed Binder Jetting:** Powder bed binder jetting printing makes use of the inkjet printing technology and uses two materials; a powder based material and a binder. The binder acts as an adhesive between powder layers. The binder is usually in liquid form and the build material in powder form. The process begins with distributing a fine layer of the powder which is followed by spraying binder in the selected area of the deposited sand

layer. Curing reactions taking place make the particles of the powder stick to each other only in the selected areas where the binder was dispensed. The process repeats itself as the platform moves downward by a set distance until all of the layers of the part are completely printed and a final powder layer is deposited [1]. The remaining unbinder powder still remains loose is brushed off leaving only the finished product.

One major advantage of the process is that there is no need for supports because the powder bed itself provides this functionality. The parts however resulting directly from the machine are not as strong as compared to other techniques and require post-processing to ensure durability.

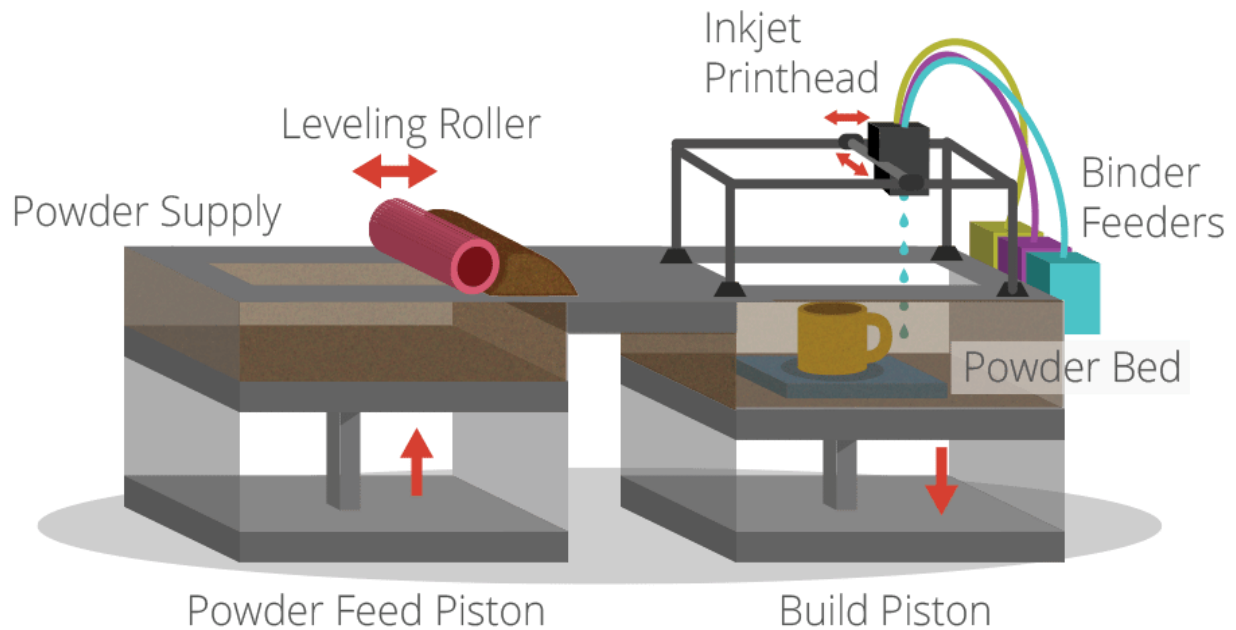

Figure 6 Powder Bed Binder Jetting Process

2.2 Sand casting

Sand is the most widely used of all the casting process because the sand offers several benefits to the casting process. The sand itself is very inexpensive and can withstand high temperatures, allowing metals with very high melting points to be cast easily. It however has a low production rate because the expendable mold must be destroyed in order to remove the final casting.

2.2.1 Types of sand casting

Depending on the preparation of the sand, the sand molds can be characterized into the following distinct types;

- i. **Green Sand Molds:** Green sand molding is a process of making molds with three essential ingredients - Sand, clay and water. It is called green sand as the mold is used green without drying. Typical composition of the mixture is 90% sand, 3% water, and 7% clay or binder. These types of sand molds are the least expensive and most widely used.
- ii. **Skin Dried Molds:** A skin dried mold is basically a green sand mold with added bonding materials which is dried to remove the moisture and to increase the mold strength. Doing this also improves the dimensional accuracy and surface finish but will lower the collapsibility of the mold. These types of mold are comparatively more expensive as compared to green sand molds.
- iii. **Dry Sand Molds:** A dry sand mold also known as called a cold box molding is the process in which the sand is mixed with an organic binder and is strengthened by baking it in an oven.
- iv. **No Bake Molds:** In no bake sand molds the sand is mixed with a resin and catalyst mixer and the curing reaction takes place at room temperature. As a result, the cured mold can immediately be used for casting.

2.3 Local Visits & Surveys

The local foundries were visited to gather information about the techniques employed by the local industry for the making of sand molds. The information gathered is briefly summarized below;

Small Scale Local Foundries

There were no standard quality procedures employed in the small scale local foundries. The molds were made out of sand obtained and sieved from the river bed and using water and molasses as a binder. They were also not aware of the 3D printing of sand molds technology.

KSB Pumps (Hassan Abdaal):

KSB Aktiengesellschaft is a universal supplier of pumps, valves and related services having one of its manufacturing facilities located in Hassan Abdal under the name of KSB Pumps. They have been one of the leading providers in their field for over 100 years.

The manufacturing facility is an international standard foundry having proper quality control and testing procedures to ensure quality castings and sand molds. Following is some of the information gathered during the visit;

- i. Sand with specified moisture content and having a GFS Grain Fineness Number approximately equal to 55 is used for the sand molds whereas the Grain Fineness Number is a method for expressing the average grain size of a given sand sample.
- ii. Two types of binders were used for the preparation of sand. One was an undisclosed organic binder for cold box sand mold making and the other was a Furan no bake resin with a sulfuric acid based initiator. However due to the highly toxic nature and strongly pungent smell of furan resin, proper care and handling was required. Furthermore, the resins and binders were specially imported from Germany since they are not available in local market.
- iii. Sand mold hardness, sand mold permeability, grain fineness number, moisture content test and metallurgical tests were some of the tests conducted to ensure the quality of the molds and castings.
- iv. Some of the higher management were aware of the 3D sand mold printing technology.

Excel Engineering (Lahore):

Excel Engineering a part of Excel Group of Companies is located in Shahdrah Lahore. It is fully equipped with state of the art engineering tools and produces high quality standard automotive and engineering products including casting. The foundry section develops a range of complex sand castings and cores using different materials like sodium silicate, resins and molasses.

The company in the past years have used a furan no bake resin for its sand castings however due to the environment unfriendly and toxic nature of the resin they switched to an alkaline phenolic binder. The resin is specially imported from Jinan Shengquan Group Share-Holding Co., ltd

(China) since it is not available in the local market. Following are the features, application procedure and the precautions for the alkaline phenolic resin;

i. **Features:** The alkaline phenolic no bake resins are a brownish-red transparent liquid cured with and organic ester.

- Resin contains no nitrogen, and the hardener is free of phosphorous and sulfur greatly reducing surface and subsurface defects.
- The resins thermoplastic properties and secondary high temperature hardening process reduce hot tear and veining defects in steel and ductile iron castings.
- Improved plant working environment as a result of no noxious or irritating odors during sand mixing, core production and pouring.
- Excellent shakeout characteristics contribute to the overall efficiency of the process.

ii. **Application Guide:**

- The sand is mixed with the hardener first and then with the resin.
- Approximately 1.2 – 2.0% resin by weight (based on sand) is added to the sand along with 20-25% hardener by weight (based on resin).
- Typical mixing time is 5 to 10 minutes. Different types of hardeners or hardeners with different curing speed can be used to adjust the curing speed.

iii. **Precautions:**

- Resin –It is corrosive to eyes, respiratory system and skin. Wear protective gloves, [protective clothing, eye protection, face protection. When contact with skin remove all contaminated clothing and wash with plenty of soap and water.
- Resin – Provide local exhaust or general room ventilation to minimize dust and/or vapor concentration. Keep away from kindling, heat source and oxidizer. Keep the container well sealed.
- Hardener – It may be irritating to eyes. Handle in accordance with good industrial hygiene and safety procedure. Ensure prompt removal from eyes, skin and clothing.
- Hardener – Provide local exhaust or general room ventilation to minimize dust or vapor concentrations. Keep away from kindling and heating source.

2.4 3DP of Sand Molds Using Additive Manufacturing

There have been advancements in the field of 3 dimensional printing of sand molds using additive manufacturing techniques over the last decade and a few commercially available 3D printers from companies like Voxeljet& EXONE have made their way into the local market. The setups however are quiet expensive and the applications and results are limited to specialized materials. Regardless of the company all the printers however make use of the powder bed binder dispersion technology for the making of sand molds because it can produce optimized parts for weight reduction. Figure 7 shows the technical specifications of a commercial 3D sand printer from ExOne.



Technical Specifications	
Process cell including job box and roller conveyor	
Build volume	1 x w x h 1800 x 1000 x 700 mm (70.9 x 39.37 x 27.56 in.)
Build speed	60,000 to 85,000 cm ³ /h (2.12 to 3.00 ft ³ /h)
Layer thickness	0.28 to 0.50 mm (0.011 to 0.0197 in.)
Print resolution	X/Y 0.1 mm / 0.1 mm (0.004 in. / 0.004 in.)
External dimensions including one job box, right - standard	1 x w x h 6900 x 3520 x 2860 mm (271.7 x 138.6 x 112.6 in.)
Weight	6500 kg (14,330 lbs.)
Electrical requirements S-Max	400V 3-Phase/N/PE / 50-60 Hz, max. 6.3 kW
Electrical requirements heater	400V 3-Phase/PE / 50-60 Hz, max. 10.5kW
Data interface	STL

Figure 7 ExOne's S-MAX 3D Sand Mold Printer

Various factors play an important role in the 3D printing of sand molds. These factors include, type of sand, grain size, binder properties, hardener properties, binder saturation, layer thickness, layer compaction, curing time, printing speed, droplet size, build orientation of job box etc. Table

2 presents the binders, properties and applications of some of the 3D printed sand molds used for casting.

Table 1 Binders, properties and applications of some of the 3D printed sand molds

Powder	Particle Size	Suitable Binder	Properties	Heat Treatment	Application
Plastic Ceramic Composite		Zb56		190° C for 4-8 h	Non-ferrous metals
Chromite, Silica	140/190/250µm	Furan or Phenol	250 - 300Ncm ⁻²	None required	Non-ferrous metals
Silica, Zircon, Chromite,	140/190/250µm	Phenolic	250 - 300Ncm ⁻²		Ferrous metals
Ceramic Beads		Furan			Grey iron & steel

The following discussion presents a review of the research already carried out on some of the factors which is available in the literature;

- Research shows that an increase in the binder saturation level for a constant layer thickness results in an increase of the tensile and flexural strengths of the molds specimens. This is however associated with a decrease in dimensional accuracy and surface quality [6].
- Research shows that an increase in the layer thickness for a constant binder saturation results in the decrease of the tensile strength and increase of the flexural strength. It also gives a better quality uniform surface [6].
- The density and surface roughness of 3D printed parts is found to be decreased in certain powder and binder combinations as compared to traditional sand molds.
- The 3DP process provides higher flexibility in the printing of the mold with the requisite runners and riser system along with the cores. Studies have shown that binder jetting process fabricates parts in shorter times with dimensional tolerances. The volume of production and the geometries complexities also have a marked effect on the costs for production.

- New powder layers can be deposited using a scrapper or a roller. A scrapper only deposits a new layer without any additional compaction while a roller also provides added compaction. The compaction further depends on the direction of rotation, speed or rotation and feed of the roller. Each technique has its advantages and disadvantages however a counter rotating roller is preferred because it creates an even and flat layer and since a forward rotating one is more prone to disturbing the new powder layer [7].
- According to a research conducted by Yaser Shanjani & Ehsan Toyserkani at the University of Waterloo (Canada), the relative densities shown in figure 9 and figure 10 can be obtained by analyzing the counter routing compaction of powder with the 1 dimensional slab approach [7]. The results however shown are valid for the following analysis parameters;
 - Friction coefficient between loose powder and underlying compacted layer = 0.5
 - Friction coefficient between roller and powder = 0.3
 - Roller radius (R) = 10mm
 - Initial powder density ($\rho_{initial}$) = 30%
 - Upper bound angle of roller (α_{in})= 0.2 radian

Whereas,

H_s = rolling gap

V = linear roller motion

ω = rotational speed

R = Roller radius

P_r = Roller pressure

α = Roll angle

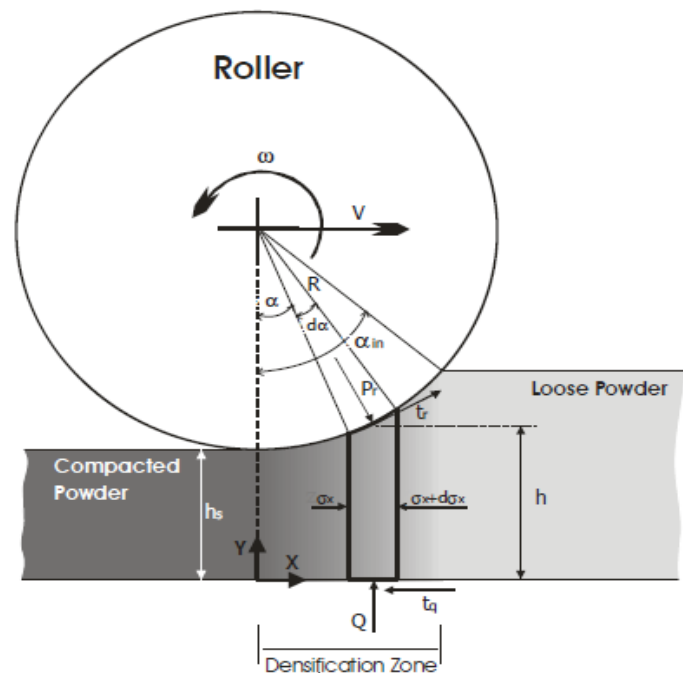

Figure 8 Powder Densification Zone

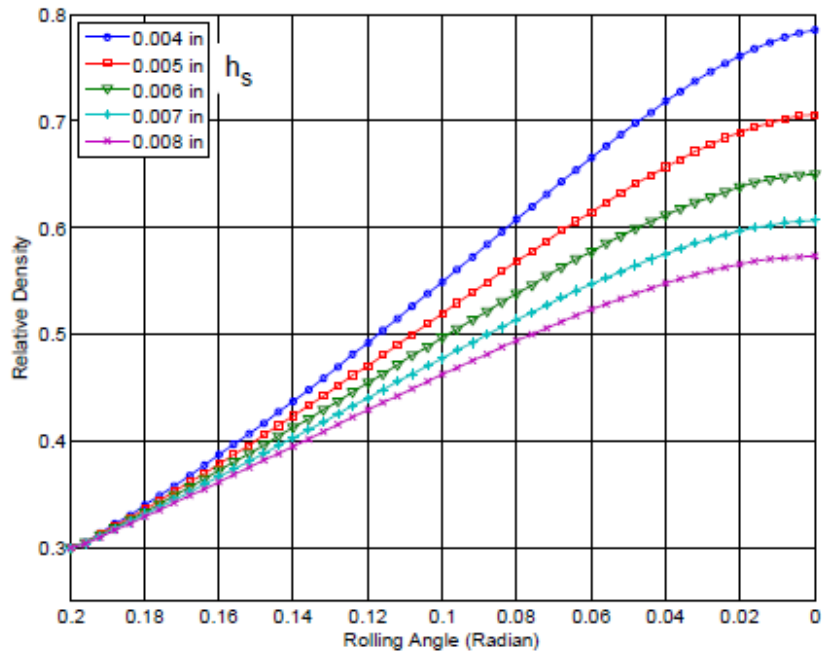

Figure 9 Effect of layer thickness on RD in powder densification zone

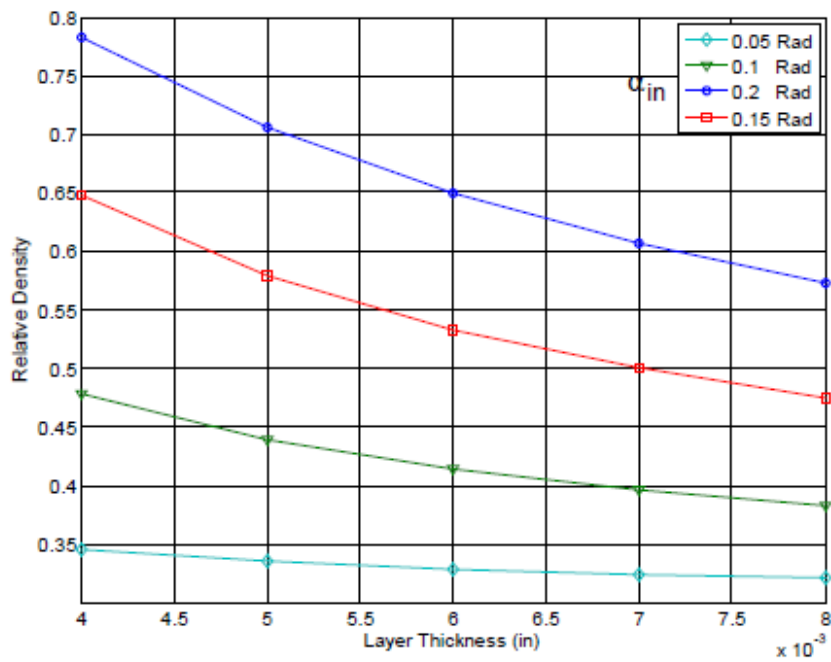

Figure 10 RD of new compacted powder layer with respect to layer thickness

- A small roller diameter and a large new layer height achieves a lower level of compaction as compared to a roller with a larger diameter and smaller layer height.
- Binder selection is of utmost importance in regards to the generation mold with high strength and requisite permeability. The binder system depends on which binder is used, which catalyst is mixed with it, if there is an activator in the sand and the comparative proportion of each. The catalyst needs to be added slowly into the sand and mixed thoroughly before the resin is introduced. The resin and catalyst should never be mixed with each other directly because the highly exothermic reaction could result in an explosion [8].
- Heat curing of the mold also has a direct effect on the sand mold properties. It improves and provides additional strength as compare to uncured molds and in some cases is even necessary to compensate for the poor compaction of the molds as compared to traditional ones. The heating however doesn't noticeably have any effect on the hardness and surface quality of the printed molds [9].

Considering all of the research that has already been done, there is significant room for further research that still needs to be carried out to develop a better understanding of the properties of parts produced by 3D printing.

CHAPTER 3: METHODOLOGY

Main idea was to develop a low cost 3D sand mold printer. As we know additive manufacturing techniques are way too expensive and keeping an eye on some of the available 3D sand printers in the market. It was decided to adopt powder bed binder jetting mechanism to make lab scale 3d sand mold printer. To achieve the goals and objectives of this project a very simple design for the functioning prototype was made. This model mainly includes two sand beds, one that act as sand feed bed and other as print bed, leveling roller, binder dispensing unit and outer body to hold these in place. Both the sand beds (feed bed and print bed) are individually operated by stepper motor to lift and lower the beds respectively. A leveling roller is used to scrap sand, layer by layer from feed bed to print bed. Binder is dispersed on each sand layer by binder jetting mechanism done with the help of Epson Stylus ink jet Printer.

3.1 Selection of Binder

Binder selection is of utmost importance in order to make mold with high strength and requisite permeability. The binder system depends on which binder is used, which catalyst is mixed with it, if there is an activator in the sand, the comparative proportion of each. There are two major categories of binders, the organic and inorganic. Organic binders don't require heat treatment whereas inorganic do at the end phase. Below figure show difference between them:

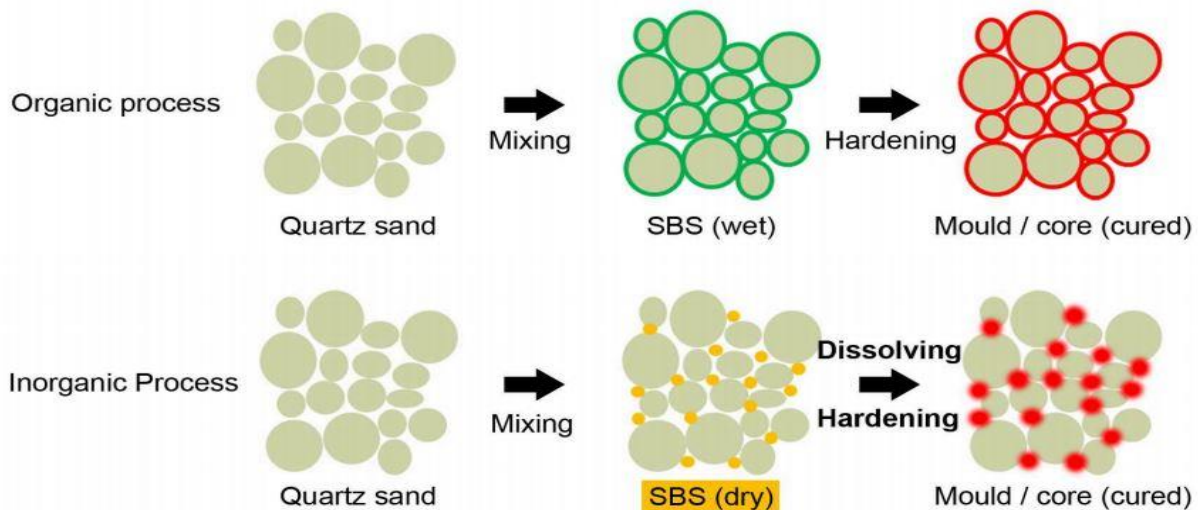

Figure 11 Difference between organic and inorganic binder processes

Furan and Phenol resins are organic binders. Furan binders were made in 1958 to provide for no-bake acid catalyzed systems. The Furan No-Bake System (FNB) system comprises of two parts, the furan resin and an acid catalyst. It can be employed to make all types of castings. The overall quantity of furan binder used is 0.9-1.2% based on sand weight. Catalyst amounts are from 20-40% based on weight of the binder. The Furan No-Bake system isn't compatible with high demand silica type sands and alkaline aggregates such as olivine. Like all other no-bake systems, temperature is of paramount importance because the catalyst needs to work in conjunction with the temperature to start and carry out the curing reaction. The color undergoes a change from green to black. Ultraviolet light brings the color back to the original brown. Catalyst choice and potency is essential for binder performance. The speed of the curing reaction is controlled by controlling the quantity of catalyst.

Furan systems provides a large number of advantages

- More reactive binder types can use milder acids like phosphoric
- Mixing with sand provides good flow ability
- Lesser smoke and odor
- It provides recognized polymerization shrinkage.
- It gives excellent dimensional accuracy
- Wide variety gives tradeoff between cost and performance.

Phenolic resin is also a non-bake system. The other option besides furan is to use phenol formaldehyde resin with an ester hardener. It has low nitrogen content. It has primarily employed for medium size casting process and is primarily used for core making process. The general content used for 1.2 – 2.0 % and the hardener is primarily in 20 – 25%. Upon combining with different speed esters in varying quantity to find appropriate curing rates at desired temperatures.

Considering the unavailability of and toxic nature of furan based no bake resins, alkaline phenolic resin and its corresponding catalyst was procured for the research directly from Excel Engineering. The binder and catalyst system have an approximate density of 1.228gm/ml & 1.173gm/ml

respectively. They were less harmful as compared to Furan based resins. It presents the following advantages:

- It doesn't give out toxic or irritating odors
- It has excellent shakeout characteristics
- Its thermoplastic properties reduce mechanical defects
- It has lower sulfur and nitrogen content
- It provides flexibility in mold handling

3.2 Selection of Print Head

After having procured the resins, a relevant print head was selected. The inkjet print head technology was taken into consideration which is primarily classified into the following two categories:

3.2.1 Piezoelectric Print Heads:

Piezoelectric print heads differ from thermal print heads in the sense that opposed to heat energy, very tiny piezoelectric crystals present in the head force the liquid out as they tend to expand when electric charge is applied. The amount of discharged liquid can be controlled with high accuracy by controlling t

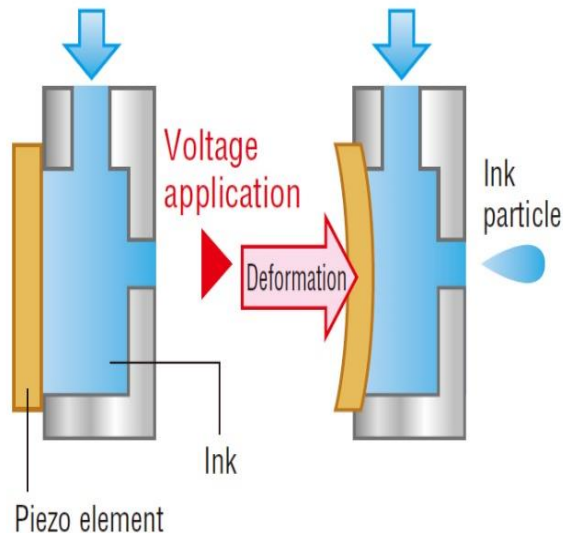

Figure 12 Piezoelectric Print Head Working Mechanism

3.2.2 Thermal Inkjet Print Heads:

Thermal print heads use heat energy to heat up the liquid and force it through the nozzles. They are one of the most common inkjet printers seen in common households because they tend to be more affordable. They however tend to burnout if run on dry conditions.

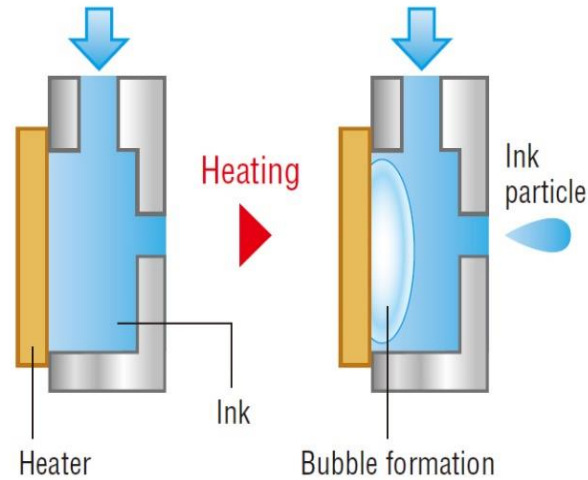

Figure 13 Thermal Print Head Working Mechanism

Taking into consideration the curing characteristic of the phenolic binder and to prevent clogging upon heating, an EPSON Stylus S22 Printer with a piezoelectric head was selected. The printer has the following specifications and was further fitted with a CISS ink supply kit to ensure a continuous supply of resin.

- Minimum Droplet Size – 4 pl
- Ink Technology –DURABrite™ Ultra
- Printing Resolution – 5,760 x 1,440 dp
- Nozzle Configuration – 90 Nozzles
black, 29 Nozzles per color
- No. of cartridges – 4



Figure 14 EPSON Stylus S22 Printer

3.3 Initial Testing

Various initial tests were performed to verify the printability of a 3D sand mold having sufficient strength. These tests are discussed below in a sequential manner

- To test the printability of the phenolic resin the ink cartridges were filled with a diluted solution of resin and water since the resin has a considerable higher viscosity as compared

to ink. Initial tests were performed using a 50:50 by volume ratio. This was subsequently increased and fixed to a 70:30 (resin to water) ratio after successful prints.

- ii. Having proven the printability of the resin, cylindrical sand molds test specimens at different resin & catalyst ratios (including a 70:30 resin to water ratio by volume) were produced to determine the conditions that were necessary to produce molds with the sufficient shape & strength. The following table summarizes the results that were obtained.

Table 2 Initial Test Results for Resin / Catalyst Ratios

Sr.	Resin	Catalyst	Compaction	Results
1.	2%	20%	Uncompacted	Failed to retain shape
2.	5%	20%	Scrapped	Retains some shape
3.	15%	20%	Scrapped	Retains shape but is lumpy
4.	3%	20%	Fully Compacted	Retains shape without lumps

The results show that too low a level of resin without any compaction fails to produce a mold that holds up and too high a level with scrapping produces lumping. Some compaction is necessary for making molds through the traditional way by mixing resin / catalyst in the approximately industrially specified ratios. Although the results aren't a 100% valid for 3D printing of sand molds since layer by layer and drop by drop deposition would overcome the problem of lumpiness, they however indicate that sufficient compaction is necessary if we wish to employ the industrially specified resin / catalyst ratios for traditional techniques.



Figure 15 Initial Test Specimens Using Traditional Ramming Method

- iii. To check layer by layer sand and resin adhesiveness, a translucent paper was fed into the printer and 1 in x 1 in resin (resin 70:30 water by volume) squares were printed. Sieved sand premixed with the activator was scrapped onto the newly deposited resin layer and excess sand was removed. The process was repeated up to 8 times for both single and double resin layers which resulted in thin wafer like test specimens (approximately 0.84mm thick). The specimens had exceptional rigidity once the water content had dried.



Figure 16 Initial Test Specimens Using Manual Layer by Layer Deposition

- iv. To measure the amount of resin printed per square inch by the printer, a pre-weighed absorbent paper is fed into the printer. The paper is weighed again after printing and the change ($5.336\text{mg}/\text{in}^2$) gives the weight of resin + water which has been deposited by the print head. Using the respective densities of the two this translates to approximately $3.958\text{ mg}/\text{in}^2$ of resin.

- v. From literature it was decided that the setup should be able to deposit sand layers of approximately 100-200 micron thickness. The printable quantity of 3.958 mg resin/in² translates to approximately 4.7 – 5.3% resin by weight for uncompacted 100 micron thick sand layer and 3.3 – 3.7% resin by weight for fully compacted 100 micron thick sand layer. Similarly, for 200 micron thickness the values come out to be 2.3-2.7% resin by weight for uncompacted and 1.6-1.9% resin by weight for fully compacted sand layers respectively. The ratios calculated approximately correspond to the industrially specified ratios and ratios used for the initial tests using traditional ramming method. These results along with the thin wafer like test specimens indicate that a single pass resin layer should be sufficient enough to 3D print sand molds with a 100-200 micron thick layer resolution.
- vi. Cylindrical test specimens using ratios for a 160 micron thick sand layer from the previous test were constructed (including a 70:30 resin to water ratio by volume) using the traditional method with different compaction levels.

The results obtained are summarized in the following table.

Table 3 Initial Test Results for Assumed 160 um Layer Thickness

Sr.	Assumed Layer Thickness	Grain Size	Compaction	Hardness	Density (gm/cm³)	Relative Density
1.	160 μm	< 150 μm	400 gm	74	1.016	46%
2.	160 μm	< 150 μm	800 gm	82	1.070	49%
3.	160 μm	< 125 μm	400 gm	73	1.024	47%
4.	160 μm	< 125 μm	800 gm	82	1.070	49%

Due to manual making, the results were not accurately reproducible to indicate a trend. The hardness however achieved was greater than the minimum acceptable threshold (~ 65) of the industrial standard. Furthermore, the relative density of the specimens was lower as compared to that of the loose bulk sand (~ 62.7%) which suggest that mold specimens printed with loosely

scrapped sand layers should have sufficient hardness. The thin wafer like test specimens printed by manual layer scrapping in the tests conducted before reinforces this suggestion. All these specimens were tested for hardness with a sand mold hardness tester and the corresponding relative density of the specimens that was recorded has been shown in above table.

3.4 Design and Development

Designing is the first step for the development of any product. All of the designing was done on Solid Work. 3D model for each part was made and then each part was manufacturing on CNC milling machine in Department of Manufacturing and Design, NUST. Whole project was fabricated and assembled inside CNC lab due to tight clearances required in the project. The design & fabrication phase can be subdivided into four broad sections

3.4.1 Sand Beds Mechanism

Binder is dispersed on the mold bed in the shape generated through 3D CAD model of mold to be prepared. After dispersion, print bed is lowered by lead equal to thickness of sand layer and simultaneously feed bed is raised by the same height. Both these operations are controlled by microcontrollers that control stepper motor operation accordingly. After each bed movement, leveling roller moves from feed bed to print bed transferring next layer of sand over the previous layer which is already been dispensed by binder. Binder then binds both these layer and again dispersion unit is used to displace binder on the new sand layer and the process is repeated till the required height of the mold is achieved.

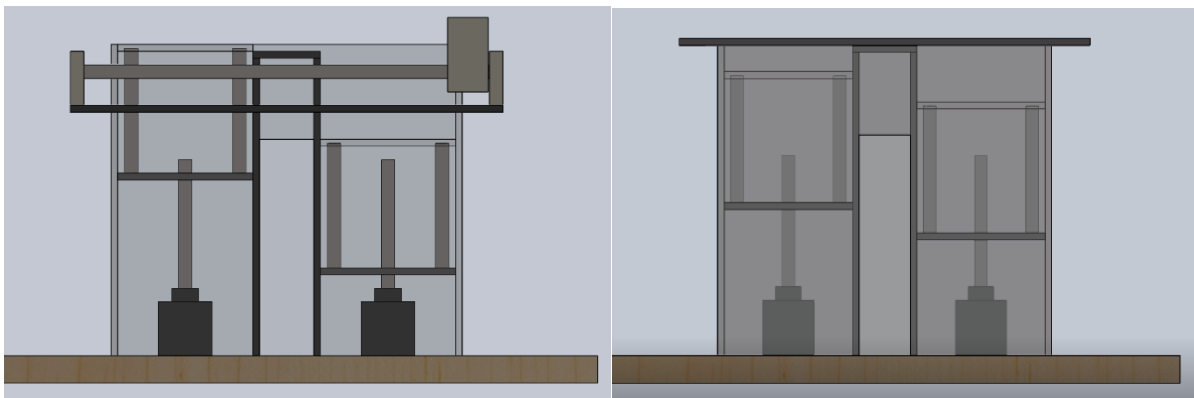

Figure 17a Front View of Sand Containers

The print bed size is restricted by the printable area of the selected printer i.e. EPSON Stylus S22 while the supply bed size is half that of the print bed to reduce the layer recoating speed.

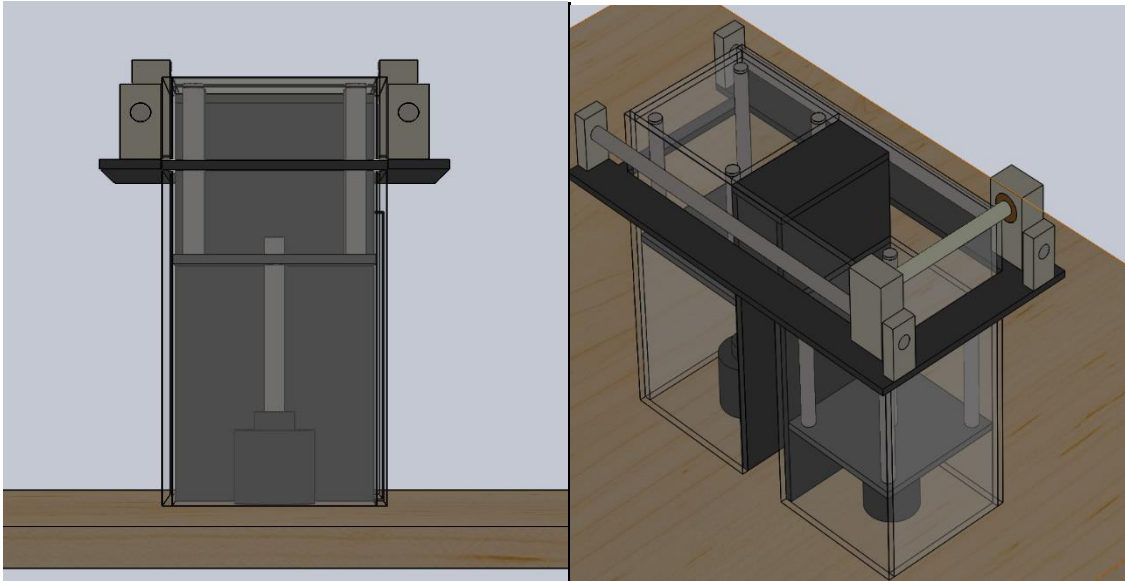

Figure 17b Side View

Figure17c Isometric View

The bed platforms move using stepper motors that are coupled with a lead screw. The combination of a 200 step stepper with a lead screw having an 8mm lead provides a resolution of 40 microns per step which is sufficient enough for our purpose. The raising structure also comprise of guide rods and linear bearings for guiding and restricting the movement of the platforms to the z-axis. The complete raising mechanism is fixed to a mild steel base plate.

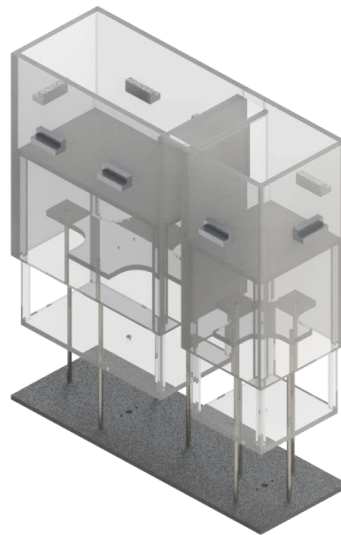

Figure 17 Complete 3D View of Sand Beds

3.4.2 Base frame

The complete powder bed platforms and binder jetting mechanism is supported using a support frame which is similar in design to that of a table. The support structure is fabricated using 18 SWG mild steel pipes which hold up the powder bed platforms while the top is made out of a 4ft x 2ft wide acrylic sheet. The complete frame measures approximately around 4ft x 2ft x 3ft.



Figure 18 Rendered 3D Model of Support Frame

3.4.3 Control Circuit

The stepper motors are controlled by an Arduino Mega 2560 and a L298N motor driver. The Arduino Mega 2560** is a microcontroller board based on the ATmega2560 while the L298N motor driver is a dual H-Bridge motor driver which allows bidirectional independent control of two DC motors or one bipolar stepper motor [10]. The motor driver acts as a current amplifier. It takes a low current logic control signal from the Arduino Mega 2560 microcontroller and turns it into a higher current signal, using an external power supply, which can drive a motor.

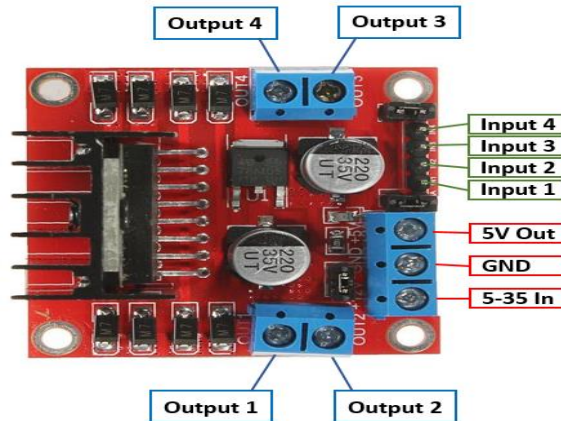

Figure 19 L298N Motor Driver Pinout Diagram

Following is the wired configuration of interfacing stepper motor and H bridge motor driver with Arduino Mega. Each of the stepper motor is controlled by a separate L298N motor driver package. Each motor driver is supplied with separate 12Volt with the help of a varying 12V adaptor. Two stepper motors are attached one for each sand container.

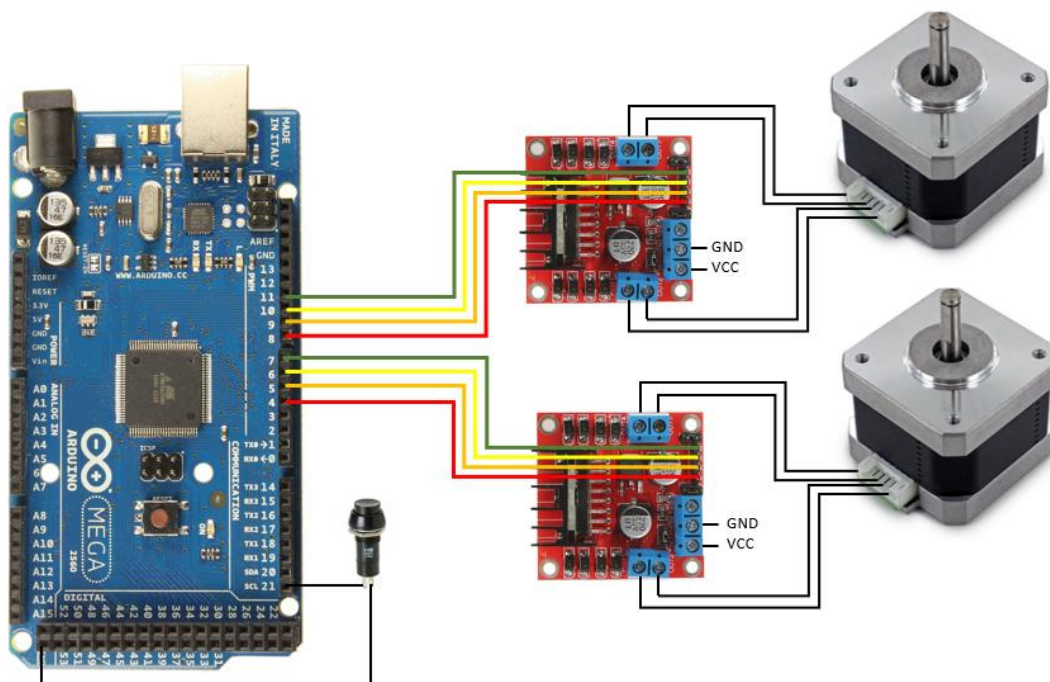

Figure 20 Wired Configuration For Controlling Sand Beds

3.4.4 Recoater

The recoater mechanism consists of a counter rotating stainless steel roller having a diameter of 16mm. The diameter has been selected taking into consideration the research already conducted by YaserShanjani& Ehsan Toyserkani and the effect of an increase in roller diameter on the compaction of the newly deposited powder layer. These studies have already been highlighted under section 2.4 of this report. Furthermore, the counter rotating roller is selected because it creates an even and flat layer as compared to a forward rotating roller which is more prone to disturbing the new powder layer [11].

A timing belt and pulley system is used to feed the roller over the beds and to deposit a new powder layer. Both the rotation of the roller and feed of the rotating roller are controlled by stepper motors

whose rpm can be adjusted to optimize the speed and feed of the roller for new layer deposition. Both the stepper motors are controlled by an individual Arduino Mega 2560 microcontroller and a L298N motor driver, the reason being that simultaneous and bidirectional movement of the two motors is required. The Arduino accelstepper library can provide a simultaneous looking movement of two or more than two motors but the movement isn't ideally speaking simultaneous since the Arduino code is executed in a sequential manner.

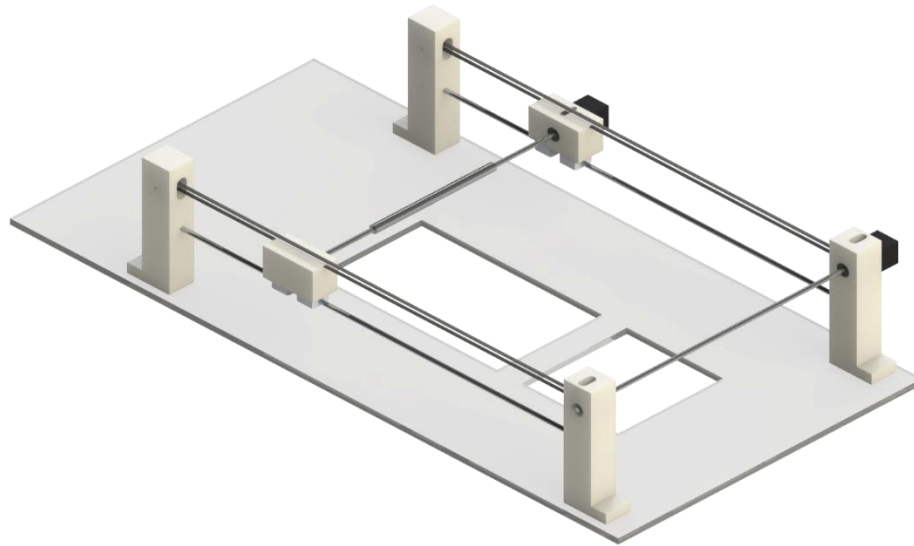

Figure 21 Rendered 3D Model of Recoater

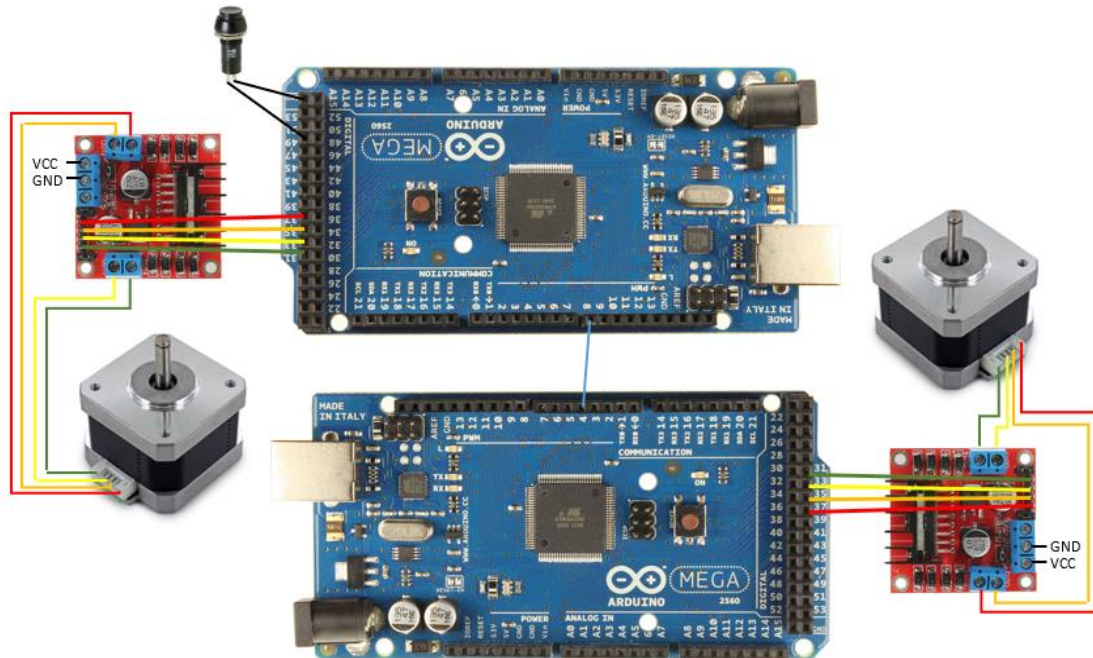

Figure 22 Recoater Control Circuit Wiring

3.4.5 Binder Jetting Mechanism

An EPSON Stylus S22 printer has been modified for the purpose of this project in such a way that the printer itself moves on the paper instead of feeding the paper (print bed). The redundant components/sensors have been removed or bypassed. Before we move on to which ones to bypass and which ones to remove, we first discuss them and the overall working of the printer in detail.

- i. **Paper Tray & Feeder Roller:** The paper tray is where the paper is loaded into the printer and stored. It contains a rubber drum like feed roller which feeds the paper inside during printing. The roller is connected to the paper feed (PF) motor through the PF roller shaft.
- ii. **Paper Sensor:** The paper sensor is an optical sensor located after the paper feed roller and before the print area. It checks if the paper has entered the print area and signals the printer if it has or has not. The printer either starts printing or gives us an error depending on this signal.
- iii. **PF Encoder:** The paper feed encoder is a dual rotary encoder connected to the PF motor and PF roller shaft. It keeps track of the rotation of the PF motor.
- iv. **PF Roller Shaft:** The PF roller shaft connects the PF motor to the pumping cap assembly and the paper feed roller.

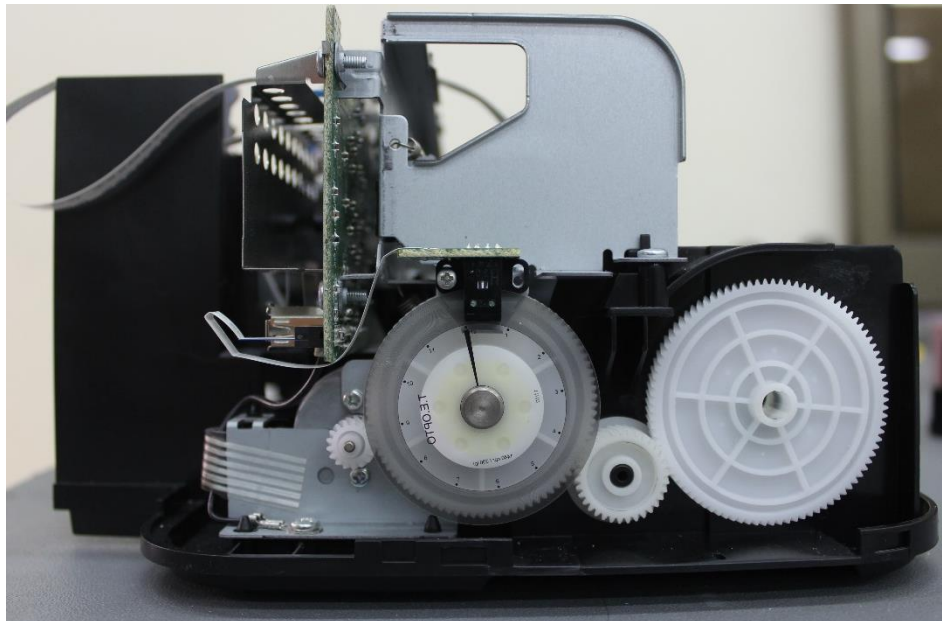

Figure 23 Assembly (Motor / Encoder / Roller)

- v. **Print Carriage:** The carriage holds the ink cartridges and the print head. It slides on a guide with the help of a timing belt that is connected to a motor. The location and movement is tracked using an encoder strip mounted on the guide and an optical sensor present on the carriage.
- vi. **Print Head:** The print head consists of micro piezoelectric elements that squeeze the ink out when an electrical charge is applied.
- vii. **Ink Cartridges:** There are 4 ink cartridges that are connected to a CISS (Continuous Ink Supply System) kit. The CISS kit consists of a reset chip and ink tanks that connect to the cartridges through silicon tubes.
- viii. **Pump Cap Assembly:** The pump cap assembly is a mechanical pump connected to the PF motor through the PF roller shaft. It is used for pumping and cleaning the print head to prevent clogging of the nozzles. The pumped ink is drained into an ink tank connected to the pump through a small rubber tube.
- ix. **Power Supply:** The power supply consists of a main power cord and adaptor which connect to the main circuit board.
- x. **Control Circuitry:** It consists of a main circuit board that controls the movement of all the components and decodes the signals received from the sensors and the computer.
- xi. **Interface port:** The printer has a USB port to connect to the computer.

The printer performs a head cleaning cycle on startup and lights up the error light if the CISS kit chip needs resetting. Once ready to print and upon receiving a print signal from the computer, the PF motor engages the feed roller through the PF roller shaft and pushes the paper from the tray to the print area. The paper must trigger the paper sensor during a certain time delay on its way to the print area or it will generate an error. If the sensor isn't triggered it means that the paper is not fed into the tray and if the sensor is already triggered before the feed roller is engaged, it means that a paper is jammed inside the print area. If triggered correctly, the printing starts and the paper is continuously fed through the rollers connected to the PF motor until it is completely pushed out and the sensor closes again.

The sequential working of the printer was carefully observed without loading any paper into the paper tray and manually triggering the sensors. This helped to determine which components to remove and which to bypass. Subsequently, the following modifications we made.

- The paper feed roller was removed
- The paper tray was removed.
- The print area was cut out and removed.
- A servo motor was connected to the paper sensor to trigger it through the arduino code.
- The PF roller shaft was cut since it interfered with the powder bed.
- To keep the pumping cap assembly still in operation a syringe was connected for manual pumping.
- The outputs of the dual rotary encoder were tapped which would act as inputs for the feeding mechanism through the Arduino Mega 2560 microcontroller.

The modified printer rests on wheeled mounts that move with the help of DC motors connected to the Arduino Mega 2560 through an L298N motor driver. The mounts are kept aligned using linear bearings and guide rods.

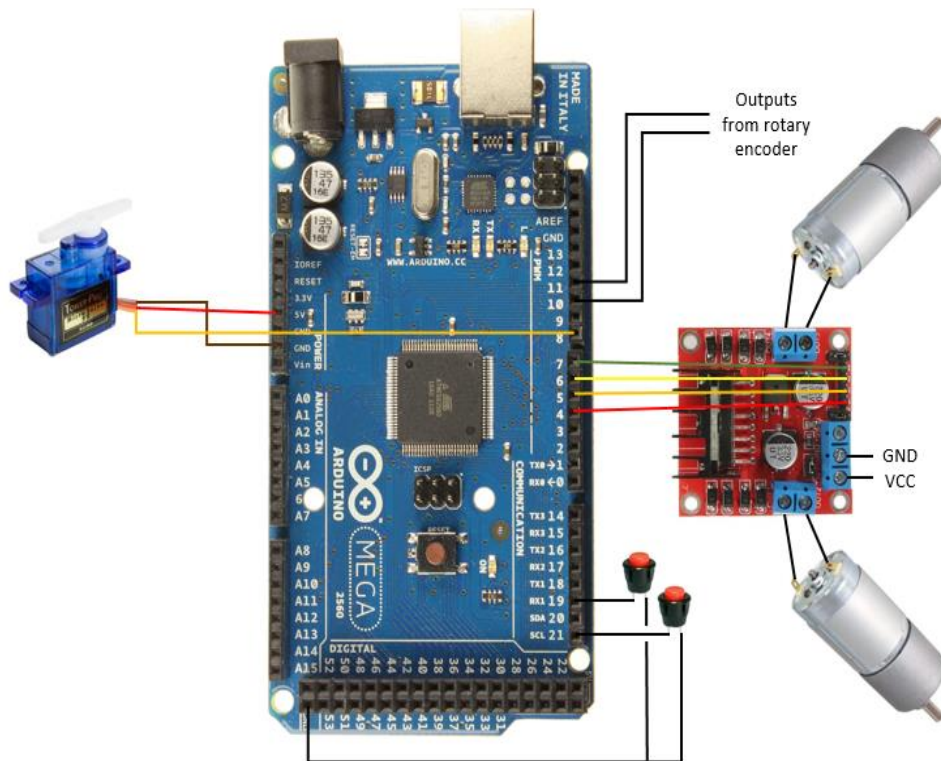

Figure 24 Print Mount Control Circuit Wiring

3.4.6 Piezo Electric Jet Head

Piezo Electric Jet Head (PEJH) is used to disperse liquid or binder onto flat surface. Previously Epson printer was used to disperse binder via inkjet print head but due to the high viscosity and sticky nature of phenolic resins it begins to clog inside the print head. It not only clogged the jetting valves of print head but also shorts the circuitry of the print head. For this issue of clogging many international companies come to a solution of making Piezo Electric Jet Heads that have ink recirculation technology.

XAAR is a company that develops world leading piezoelectric drop-on-demand (DOD) inkjet technologies. The TF ink recirculation technology and Hybrid Side – Shooter architecture ensures a continuous fluid flow at a high rate directly past the back of the nozzle which can prevent the resin from curing and subsequently clogging the channels [12]. Furthermore, in some print heads TF Technology can also be set to operate in Pulsed mode – fluid is recirculated when the print head is not jetting. Print heads by Xaar are capable of dispensing millions of droplets per second. The Xaar 1003 family of print heads can repeatedly jet fluids volumes in the range of between 1-42 pl with an extremely high degree of accuracy. The variable drop print heads can give flexibility in choosing the drop sizes and the relationship between the drop size and 3D printed mold properties.

1) Limitations of Inkjet Print head:

- The print head does not deposit sufficient resin to provide adequate strength to the mold.
- The print head isn't suitable for the resin since it easily clogs.
- Hence a specialized print head was required for 3D printing sand molds for casting applications. So work on Piezoelectric jetting technique was carried out to cater this problem.

As the Inkjet print clogged and was not able to efficiently accomplish the task anymore and XAAR print heads were very expensive to be used for our lab scale 3D sand mold printer. So there was need to make a Prototype of Piezo Electric jet head. It was developed by using Piezo vibration sensor. It was also made on lab scale so as to study the droplet dispersion properties of binder.

2) Design of piezo jet head:

Piezo electric Jet Head consisted of two specially designed acrylic plates that were placed back to back having cavity in between them. This hollow cavity contained the binder solution that needed to be sprayed on the bottom surface via nozzle. In hollow cavity from one side binder is enter and from other side water is enter for cleaning purpose only. On top of acrylic plate there is a through hole equal to the diameter of Piezo sensor, this sensor is placed above the hole in such a way that it vibrates the fluid.

There is a nozzle at the bottom that allow to spray binder depending on vibration caused by the Piezo sensor. Piezo sensor was controlled electronically with the help of Arduino and signals were passed according to our need of jetting the binder through nozzle at bottom of head. Back plate is place on top of piezo sensor so as to provide vacuum inside the hollow cavity. Cavity is fully insulated so that vibrating sensor has maximum impact on the binder solution and change in pressure cause the droplet dispersion of binder possible via nozzle. Nozzle is also specially designed and can be changed depending upon the concentration of solution made up of phenolic binder and water.

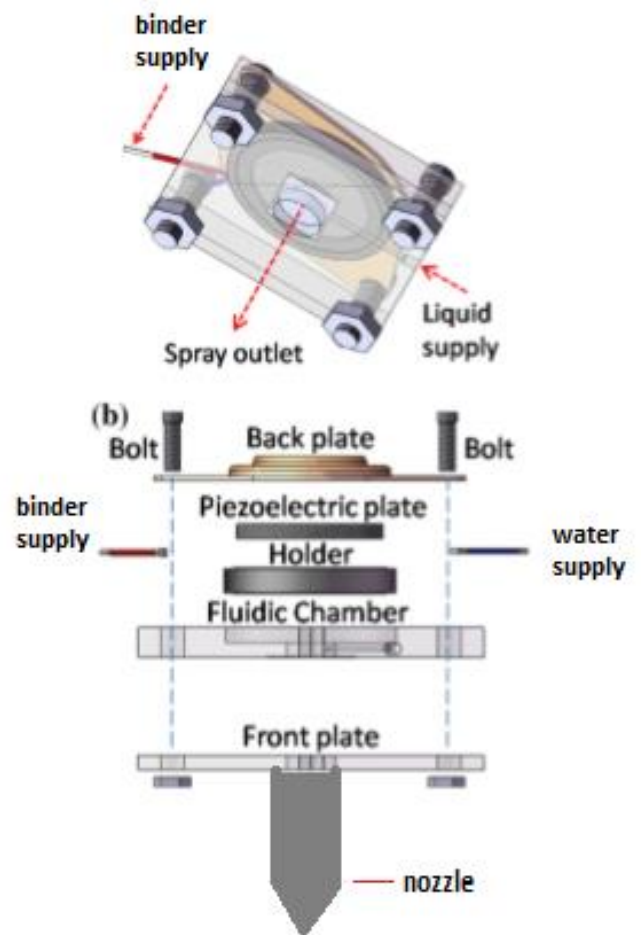

CHAPTER 4: TESTING & RESULTS

The lab scale setup once fabricated and assembled was ready for testing and calibration. This chapter discusses the operating instructions, the various tests carried out and the outcomes of these tests.

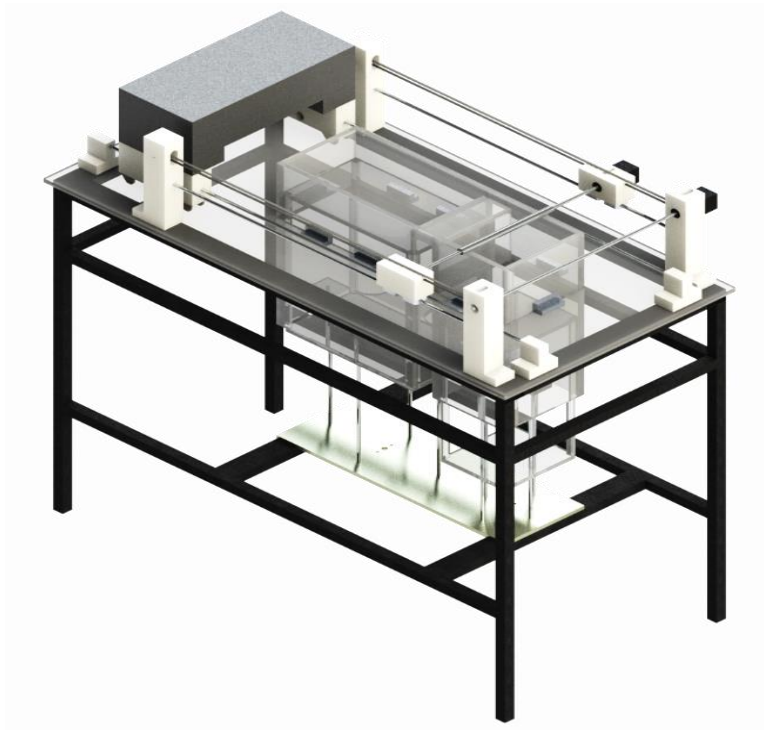

Figure 25 Rendered 3D Model of Final Assembly

4.1 Operating Instructions

The following is a step by step guide to prepare and operate the setup.

- i. Fill the CISS tank and cartridges with a resin/water solution having a 70:30 ratio.
- ii. Insert the cartridges into the print carriage.
- iii. Sieve sand (grain size subjected to desired layered thickness) and mix the catalyst into the sand. Fill the supply tank and the bed of the print tank with this premixed sand.
- iv. Connect the power cables to the control panels and the printer.
- v. Connect the control panel and the printer to the laptop.
- vi. Turn the printer on and manually charge the resin in the print head.
- vii. Press the recoat button to smoothen the powder bed.

- viii. Place the printer in the printing position and send the print command from the laptop.
- ix. Manually trigger the printer using the trigger buttons located on the control panel. Close the trigger once printing is complete.
- x. Once the printer returns to its idle position press the platform step button to move the bed platforms.
- xi. Press the recoat button to deposit a new sand layer.
- xii. Repeat steps viii through xi till a final layer sand layer is deposited.
- xiii. Remove the cartridges from the print head and clean them both to prevent clogging of the system.
- xiv. Turn the system off and let the part cure for at least 24 hours.

Remove the part from the powder bed and clear off the excess sand.

4.2 Testing & Results

Tests were performed and the system was adjusted accordingly based on the results. The following table summarizes outputs of the various tests performed.

Table 4 Brief Summary of Testing and Results

No.	Parameter	Setting	Result
1	Recoater mechanism	Counter Rotating Roller	The roller while depositing a new sand layer would disturb the previous layer and tend to slide it forward.
	Layer thickness	120 μm	
	No. of resin passes	1 pass	
2	Recoater mechanism	Counter Rotating Roller	The roller doesn't disturb the previous layers while depositing a new layer however the resin deposited from the print head isn't sufficient enough to hold the layers together.
	Layer thickness	160 μm	
	No. of resin passes	1 pass	
3	Recoater mechanism	Counter Rotating Roller	

	Layer thickness	160 μm	The roller while depositing a new sand layer would disturb the previous layer and tend to slide it forward.
	No. of resin passes	2 pass	
4	Recoater mechanism	Counter Rotating Roller	The roller while depositing a new sand layer would disturb the previous layer and tend to slide it forward.
	Layer thickness	240 μm	
	No. of resin passes	2 pass	
5	Recoater mechanism	Counter Rotating Roller	The roller while depositing a new sand layer would disturb the previous layer and tend to slide it forward.
	Layer thickness	280 μm	
	No. of resin passes	2 pass	
6	Recoater mechanism	Counter Rotating Roller	The roller doesn't disturb the previous layers while depositing a new layer however the resin deposited from the print head isn't sufficient enough to hold the layers together.
	Layer thickness	320 μm	
	No. of resin passes	2 pass	
7	Recoater mechanism	Scrapper + forward rotating roller	The roller doesn't disturb the previous layers while depositing a new layer since it doesn't provide any compaction however the resin deposited from the print head isn't sufficient enough to hold the layers together.
	Layer thickness	120 μm	
	No. of resin passes	1 pass	
8	Recoater mechanism	Scrapper + forward rotating roller	The roller doesn't disturb the previous layers while depositing a new layer since it doesn't provide any compaction however the resin deposited from the print head isn't sufficient enough to hold the layers together.
	Layer thickness	120 μm	
	No. of resin passes	2 pass	

The recoating mechanism which initially consisted of only a counter rotating roller was modified to a scrapper with a forward rotating roller to be able to deposit new sand layers without disturbing the previous ones. The new mechanism was able to deposit 120 μm layers without disturbing the previous layers for both single pass and double pass resin layers since is provided no compaction.

The layers were however still not able to properly stick together providing sufficient strength to the test mold. This outcome contradicts the deduction made earlier that a single pass resin layer should be sufficient enough to 3D print sand molds with a 100-200 micron thick layer resolution. The reason being the presence of granular interlocking which isn't present when a new layer is deposited using a scrapper and roller mechanism with no compaction.

Apart from the layer deposition problem that was resolved another major problem that was encountered was the clogging of the print head nozzles. Even though the solution consisted of 30% water (by volume) the nozzles were ending up clogged. The solution was hence further diluted to contain 40% water (by volume) which still did not resolve the problem. Various chemicals such as acetone, methanol, ethanol, chloroform, IPA etc. were tried to clear the head and to dissolve the cured resin but to no avail.

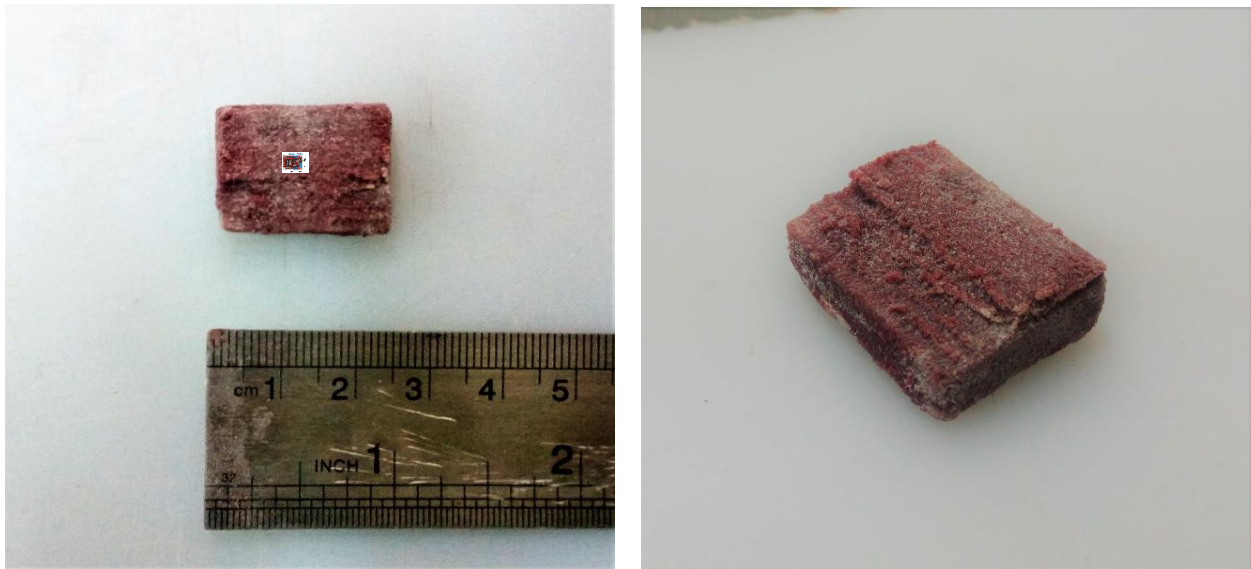

Figure 26 3D Printed Sand Mold Sample

CHAPTER 5: CONCLUSION & FUTURE WORK

The main objective of the research was to develop a 3D sand mold printing setup using layer deposition & drop jet technology that can be furthered researched and worked on. The development of the lab scale setup has been discussed in chapter 3 in detail while the results obtained from the testing of the system have been discussed in chapter 4. This chapter summarizes the outcomes of the research and recommends future work.



Figure 27 Developed 3D Sand Mold Printer Setup

5.1 Conclusion

The objectives that are mentioned in chapter 1 have been successfully achieved step by step. Through the testing that was carried out and has been discussed in chapter 4, it can be concluded that even though the system is able to print a sand mold, a recoater mechanism able to provide compaction without disturbing the previous layers and a print head able to deposit higher quantities of resin is required to print molds having sufficient strength.

5.2 Recommendations for Future work

The setup in its current state isn't able to print sand molds having sufficient strength for casting applications. After carefully concluding the results from the testing of the setup, the limitations of the setup can be worked out in the future with the help of the following suggestions:

- i. The size and capacity of both the beds can be increased to print bigger molds.
- ii. The curing time can be decreased by heating the bed by installing heaters.
- iii. A GUI interface can be made for ease of control.
- iv. The scrapper and roller of the recoater mechanism can be adjusted to give a suitable level of compaction, for increasing the mold strength, without disturbing the previous layers. Subsequently the result of compaction on the mold characteristics can be studied.
- v. Piezo Jet Head worked fine in initial tests on lab scale but few problems were also faced. There should be proper insulation so as to provide vacuum inside the chamber for better jetting.
- vi. Piezo Electric Jet Head assembly can be minimize in size so as to achieve more accurate results ,moreover nozzle of Jet Head need to be more efficient and capable in design.
- vii. To resolve the head clogging program a piezoelectric print head by Xaar can be used. Xaar is a company that develops world leading piezoelectric drop-on-demand (DOD) inkjet technologies. The TF ink recirculation technology and Hybrid Side – Shooter architecture ensures a continuous fluid flow at a high rate directly past the back of the nozzle which can prevent the resin from curing and subsequently clogging the channels [12]. Furthermore, in some print heads TF Technology can also be set to operate in Pulsed mode – fluid is recirculated when the print head is not jetting.
- viii. Print heads by Xaar are capable of dispensing millions of droplets per second. The Xaar 1003 family of print heads can repeatedly jet fluids volumes in the range of between 1-42 pl with an extremely high degree of accuracy. The variable drop print heads can give flexibility in choosing the drop sizes and the relationship between the drop size and 3D printed mold properties can be studied. Furthermore, the relationship between the resin

concentration and the mold characteristics can also be studied.



Figure 28 End Shooter VS Xaar's Hybrid Side Shooter Technology

- ix. The following components / systems may also need to be purchased for developing the binder jetting system using a Xaar print head;
 - a. Xaar Midas Ink Supply System
 - b. Xaar Midas communication pack
 - c. Inkjet Development System
 - d. Xaar Head Personality Card
 - e. Xaar XUSB Drive Electronics
 - f. Xaar Hydra Ink Supply System
 - g. Xaar Print Manager (XPM)
- x. Motors with a higher torque may be used to move the bed to ensure that it does not jam. A feedback loop can also be connected for monitoring.
- xi. The setup can be enclosed in a closed container with a proper ventilation system.

APPENDIX A

Code for Arduino # 1

```
#include <Stepper.h>

const int stepsPerRevolution1 = 12; // supply tank motor
const int stepsPerRevolution2 = 5; // print tank motor
const int stepsPerRevolution3 = 480; // roller feed motor

// initializing the stepper library on pins:

Stepper myStepper1(stepsPerRevolution1, 5, 6, 7, 8);
Stepper myStepper2(stepsPerRevolution2, 32, 34, 36, 38);
Stepper myStepper3(stepsPerRevolution3, 9, 10, 11, 12);

void setup()
{
  // setting the motor speed in rpm:

  myStepper1.setSpeed(50);
  myStepper2.setSpeed(50);
  myStepper3.setSpeed(27);

  // initializing the serial port:

  pinMode(19, OUTPUT);
  digitalWrite(19, HIGH);

  pinMode(18, OUTPUT);
  digitalWrite(18, HIGH);

  Serial.begin(9600);
}

void loop()
```

```

{
if (digitalRead(21)==LOW)
{
// move platforms one step in forward direction
myStepper1.step(stepsPerRevolution1);
myStepper2.step(stepsPerRevolution2);
}
if (digitalRead(20)==LOW)
{
// move platforms one step in reverse direction
myStepper1.step(-stepsPerRevolution1);
myStepper2.step(-stepsPerRevolution2);
}
if (digitalRead(19)==LOW)
{
digitalWrite(18, LOW);
delay (10);
digitalWrite(18, HIGH);

// start roller feed
myStepper3.step(-stepsPerRevolution3);
myStepper3.step(-stepsPerRevolution3);
myStepper3.step(-stepsPerRevolution3);
myStepper3.step(-stepsPerRevolution3);
myStepper3.step(-stepsPerRevolution3);
}
}

```



```
myStepper3.step(-stepsPerRevolution3);  
myStepper3.step(-stepsPerRevolution3);  
delay (150);  
myStepper3.step(stepsPerRevolution3);  
myStepper3.step(stepsPerRevolution3);  
myStepper3.step(stepsPerRevolution3);  
myStepper3.step(stepsPerRevolution3);  
myStepper3.step(stepsPerRevolution3);  
myStepper3.step(stepsPerRevolution3);  
myStepper3.step(stepsPerRevolution3);  
}  
}
```

APPENDIX B

Code for Arduino # 2

```
#include <Stepper.h>
#include <Servo.h>

Servo myservo;

int pos = 0;

const int stepsPerRevolution = 500;

// initializing the stepper library on pins

Stepper myStepper(stepsPerRevolution, 4, 5, 6, 7);

void setup()
{
  myservo.attach(8);
  myservo.write(105);
  // set the speed in rpm
  myStepper.setSpeed(12);
  pinMode(19,INPUT_PULLUP);
  pinMode(10, OUTPUT);
  pinMode(12, OUTPUT);
  pinMode(2,INPUT_PULLUP);
}

void loop()
{
  digitalWrite(10 , LOW);
  digitalWrite(12 , LOW);
```

```

if (digitalRead(2)==LOW)
{
  for (int i=0; i <= 60; i++)
  {
    digitalWrite(10 , HIGH);
    digitalWrite(12 , HIGH);
    delay (5);
    digitalWrite(10 , LOW);
    digitalWrite(12 , LOW);
    delay (2200);
  }
}
if (digitalRead(21)==LOW)
{
  myservo.write(80);
}
if (digitalRead(20)==LOW)
{
  myservo.write(105);
}
if (digitalRead(19)==LOW)
{
  // start rotating roller
  myStepper.step(-stepsPerRevolution);
}

```

```
myStepper.step(-stepsPerRevolution);  
myStepper.step(-stepsPerRevolution);  
delay (1500);  
myStepper.step(stepsPerRevolution);  
myStepper.step(stepsPerRevolution);  
myStepper.step(stepsPerRevolution);  
}  
}
```

REFERENCES

- [1] M. T. S. a. M. E. M. Upadhyay, "3D printing for rapid sand casting—A review," *Journal of Manufacturing Processes* 29, pp. 211-220, 2017.
- [2] K. V. a. A. H. Wong, "A review of additive manufacturing," *ISRN Mechanical Engineering* , 2012.
- [3] E. M. C. P. W. D. B. a. J. C. Sachs, "Three dimensional printing: rapid tooling and prototypes directly from a CAD model," *Journal of Engineering for Industry* , vol. 114, no. 4, pp. 481-488, 1992.
- [4] M. a. B. S. B. Srinivas, " A Critical Review on Recent Research Methodologies in Additive Manufacturing," *Materials Today: Proceedings*, vol. 4, no. 8, pp. 9049-9059, 2017.
- [5] S. S. a. M. K. Gill, "Comparative study of 3D printing technologies for rapid casting of aluminium alloy," *Materials and Manufacturing Processes*, vol. 24, no. 12, pp. 1405-1411, 2009.
- [6] M. a. C. K. C. Vaezi, "Effects of layer thickness and binder saturation level parameters on 3D printing process," *The International Journal of Advanced Manufacturing Technology* , no. 53, pp. 275-284, (2011):.
- [7] Y. a. E. T. Shanjani, "Material spreading and compaction in powder-based solid freeform fabrication methods: mathematical modeling.," *19th Annual International Solid Freeform Fabrication Symposium, SFF*, vol. 2008, 2008.
- [8] D. G. A. D. P. P. P. V. T. a. C. G. Anand, "Study of mould hardness for alpha set type resin bonded moulding sand system using Taguchi approach for metal casting applications," *MATEC Web of Conferences*, vol. 144, 2018.
- [9] K. M. M. P. J. M. V. T. D. J. D. B. a. E. G. Nyembwe, "Physical properties of sand parts produced using a Voxeljet VX1000 three-dimensional printer," *South African Journal of Industrial Engineering*, vol. 27, no. 3, pp. 136-142, 2016.

- [10] S. K. S. C. K. T. a. K. M. Korkua, "Development and evaluation of multi-stage phase-controlled converter for magnetron driver," *Robotics and Manufacturing Automation (ROMA), 2016 2nd IEEE International Symposium*, pp. 1-6, 2016.
- [11] A. a. T. H. V. Budding, "New strategies for powder compaction in powder-based rapid prototyping techniques," *Procedia CIRP* , vol. 6, pp. 527-532, 2013.
- [12] J. e. a. Brünahl, "Xaar's Inkjet Printing Technology and Applications," in *Handbook of Industrial Inkjet Printing: A Full System Approach* , 2017, pp. 285-312.