

Development of Forward Flow Forming Model in ABAQUS for Al
7075 Alloy to Verify Experimental Results and Material Behavior
Under Flow Forming Forces



Author

Zubair Hassan

00000275129

Supervisor

Dr. Shahid Ikram Ullah Butt

DESIGN AND MANUFACTURING ENGINEERING
SCHOOL OF MECHANICAL & MANUFACTURING ENGINEERING
NATIONAL UNIVERSITY OF SCIENCES AND TECHNOLOGY
ISLAMABAD
Aug, 2022

Development of Forward Flow Forming Model in ABAQUS for Al
7075 Alloy to Verify Experimental Results and Material Behavior
Under Flow Forming Forces

Author

Zubair Hassan

Regn Number

00000275129

A thesis submitted in partial fulfillment of the requirements for the degree of
MS Design and Manufacturing Engineering

Thesis Supervisor:

Dr. Shahid Ikram Ullah Butt

Thesis Supervisor's Signature: _____

DESIGN AND MANUFACTURING ENGINEERING
SCHOOL OF MECHANICAL & MANUFACTURING ENGINEERING
NATIONAL UNIVERSITY OF SCIENCES AND TECHNOLOGY,
ISLAMABAD
Aug,2022

Thesis Acceptance Certificate

It is certified that the final copy of MS thesis written by Zubair Hassan (Registration No. 275129) of department of Design and Manufacturing Engineering has been verified by undersigned, found complete in all respect as per NUST statutes / regulations, is free from plagiarism, errors and mistakes and is accepted as a partial fulfilment for award of MS degree.

It is further certified that necessary amendments as pointed out by GEC members of the scholar have also been incorporated in this dissertation.

Signature:

Date: _____

Dr. Shahid Ikram Ullah Butt (Supervisor)

Signature HOD: _____

Date: _____

Principal: _____

Date: _____

MASTER THESIS WORK

We hereby recommend that the dissertation prepared under our supervision by **Zubair Hassan 275129** Titled “Development of Forward Flow Forming Model in ABAQUS for Al 7075 Alloy to Verify Experimental Results and Material Behavior Under Flow Forming Forces” be accepted in partial fulfillment of the requirements for the award of MS degree and awarded grade

Examination Committee Members

1 Dr. Syed Hussain Imran Signature: _____

2 Dr. Aamir Mubashir Signature: _____

3 Dr. Najam ul Qadir Signature: _____

Supervisor's name: Signature: _____

Dr. Shahid Ikram Ullah Butt Date: _____

Head of Department: _____

Date: _____

COUNTERSIGNED

Date: _____

Dean/Principal

Declaration

I certify that this research work titled *“Development of Forward Flow Forming Model in ABAQUS for Al 7075 Alloy to Verify Experimental Results and Material Behavior Under Flow Forming Forces”* is my own work. The work has not been presented elsewhere for assessment. The material that has been used from other sources it has been properly acknowledged / referred.

Signature of Student

Zubair Hassan

00000275129

Plagiarism Certificate (Turnitin Report)

This thesis has been checked for Plagiarism. Turnitin report endorsed by Supervisor is attached.

Signature of Student

Zubair Hassan

Registration Number

00000275129

Signature of Supervisor

Copyright Statement

- Copyright in text of this thesis rests with the student author. Copies (by any process) either in full, or of extracts, may be made only in accordance with instructions given by the author and lodged in the Library of NUST School of Mechanical & Manufacturing Engineering (SMME). Details may be obtained by the Librarian. This page must form part of any such copies made. Further copies (by any process) may not be made without the permission (in writing) of the author.
- The ownership of any intellectual property rights which may be described in this thesis is vested in NUST School of Mechanical & Manufacturing Engineering, subject to any prior agreement to the contrary, and may not be made available for use by third parties without the written permission of the SMME, which will prescribe the terms and conditions of any such agreement.
- Further information on the conditions under which disclosures and exploitation may take place is available from the Library of NUST School of Mechanical & Manufacturing Engineering, Islamabad.

Acknowledgements

I am thankful to my Creator Allah Subhana-Watala to have guided me throughout this work at every step and for every new thought which You setup in my mind to improve it. Indeed, I could have done nothing without Your priceless help and guidance. Whosoever helped me throughout the course of my thesis, whether my parents or any other individual was Your will, so indeed none be worthy of praise but You.

I am profusely thankful to my beloved parents who raised me when I was not capable of walking and continued to support me throughout in every department of my life.

I would also like to express special thanks to my supervisor Dr. Shahid Ikram Ullah Butt for his help throughout my thesis and also for CIM and QRM courses which he has taught me. I can safely say that I haven't learned any other engineering subject in such depth than the ones which he has taught.

I would also like to thank Dr. Syed Hussain Imran, Dr. Aamir Mubashir and Dr. Najam Ul Qadir for being on my thesis guidance and evaluation committee and express my special thanks to Dr Najam UL Qadir for his help.

I would also like to pay special thanks to Engr Muzamil Ahmad Shabbir for his tremendous support and cooperation. Each time I got stuck in something; he came up with the solution. Without his help I wouldn't have been able to complete my thesis. I appreciate his patience and guidance throughout the whole thesis. Also, I would like to thank Engr Muhammad Umar Elahi, Engr Muhammad Muzamil, Engr M. Hassan Zafar, Engr Muhammad Awais, Engr Hamza Majeed and Engr Asim Ali Mirza for their support and guidance.

Finally, I would like to express my gratitude to all the individuals who have rendered valuable assistance to my study.

Dedicated to my exceptional parents and adored siblings whose tremendous support and cooperation led me to this wonderful accomplishment.

Abstract

Flow forming process is used to produce axis symmetric cylindrical parts with high precision. In the Aerospace sector, the flow forming method is employed extensively, particularly in the manufacture of missile casings and rocket motors. The nature of the process of flow forming is usually complex with high deformations with nonlinear behavior. Essentially, there are two processes of flow forming i.e. The forward flow forming and backwards flow forming. In this investigation the forward flow forming strategy was applied in which the roller and preform extrudes in the same direction. The present investigation will discuss the flow forming of Al7075 alloy. A 3D Thermomechanical finite element model for forward flow forming of cylindrical workpiece of Al7075 alloy was developed in ABAQUS/Explicit Software. In order to correctly predict forces, instead of stress strain curve, the Johnson Cook material failure for Al7075 was used and its parameters were considered. The research work verified the experimental data with the Finite element analysis results. Changes in mandrel and feed speed were also examined for flow formation purposes. Additionally, the findings of the experiments were compared to the theoretical results. It was determined that the greatest force generated was axial, followed by radial and finally circumferential. In addition, the feed impact was investigated, and it was shown that an increase in feed also increases the axial force.

Key Words: Flow Forming Process, Finite Element Analysis, Manufacturing, Forming Process, Spinning.

Table of Contents

CHAPTER 1: INTRODUCTION.....	1
1.1 Background	1
1.2 Aims and Objective.....	2
CHAPTER 2: LITERATURE REVIEW	3
2.1 Flow Forming Process.....	3
2.2 Types of Flow Forming Process	3
2.3 Advantages of Flow Forming Process	4
2.4 Applications of Flow Forming Process.....	4
2.5 Parameters in Flow Forming Process.....	4
2.6 Forces in Flow Forming Process.....	6
2.7 Foundation Paper for Research	8
2.8 Simulation Approach using ABAQUS	9
2.9 Material Properties for AL 7075 Alloy	10
2.9.1 Johnson Cook Model Properties of AL 7075	11
CHAPTER 3 RESEARCH METHODOLOGY.....	12
3.1 Methodology Flow Chart	12
3.2 Parameters Selections.....	13
3.2.1 Feed Rate	13
3.2.2 Mandrel Speed	13
3.3 Design of Experiments	13
CHAPTER 4 MODELLING IN ABAQUS	14
4.1 Model Development for Al 7075 O Alloy	14
4.1.1 Part Modelling	14
4.1.2 Material	16
4.1.3 Assembly.....	17
4.1.4 Step	18
4.1.5 Interaction	22
4.1.6 Boundary Condition.....	23
4.1.7 Mesh.....	24
4.1.8 Mesh Convergence.....	25

4.1.9	Validating the Mesh Convergence Model	26
4.1.10	Model Validation	27
CHAPTER 5: SIMULATIONS RESULTS AND CONCLUSION		30
5.1	Results	30
5.1.1	Simulation 1	30
5.1.2	Simulation 2	32
5.1.3	Simulation 3	34
5.1.4	Simulation 4	36
5.2	Comparison with Experimental.....	37
5.3	Conclusion.....	38
5.4	Future Work	38
References		39

List of Figures

Figure 1	Conventional Spinning Process [1]	1
Figure 2	Forward and Backward Flow Forming Process [3].....	3
Figure 3	Parameters effecting Forces, Von Misses & Plastic Strain [4]	5
Figure 4	Forces During Flow Forming Process [10]	7
Figure 5	Experimental setup for Flow Forming [11].....	8
Figure 6	Process Parameters During Experiment [11]	8
Figure 7	Modelling of Roller in Abaqus.....	14
Figure 8	Modelling of Mandrel in Abaqus	15
Figure 9	Modelling of Preform in Abaqus.....	16
Figure 10	Units Conversion in Abaqus.....	16
Figure 11	Material Properties of Al 7075 Incorporated into Abaqus	17
Figure 12	Assembly Creation of Flow Forming Setup in Abaqus	18
Figure 13	Roller Displacement and Rotation along Z Axis.....	19
Figure 14	Mandrel Fixed along all Axis	20
Figure 15	Preform encastered along inner edge	21
Figure 16	Mass Scaling applied during Simulation.....	22
Figure 17	General contact interaction used in Modelling.....	22
Figure 18	Interaction properties and coefficient of friction.....	23
Figure 19	Velocity and Angular velocity incorporated into the Model.....	23
Figure 20	Meshing with C3D8R elements.....	24
Figure 21	Meshing of Flow forming model.....	25
Figure 22	Mesh Convergence Graph	26
Figure 23	Mesh Size of 2mm Incorporated in Abaqus Model.....	26

Figure 24 Graph between Internal Energy and Kinetic Energy	27
Figure 25 a) Actual Model b) Model developed for Validation	27
Figure 26 Max Von mises graph [6]	28
Figure 27 Max Von misses achieved for Validation	28
Figure 28 Circumferential Stress for both the models	29
Figure 29 Von Mises occurring in Preform Case 1	30
Figure 30 Magnitude of Normal Force in Case 1	31
Figure 31 Von Mises occurring in Preform Case 2	32
Figure 32 Magnitude of Normal Force in Case 2	32
Figure 33 Von Mises occurring in Preform Case 3	34
Figure 34 Magnitude of Normal Force in Case 3	34
Figure 35 Von Mises occurring in Preform Case 4	36
Figure 36 Magnitude of Normal Force in Case 4	36

List of Tables

Table 1 Aluminum 7075 Chemical Composition [15]	10
Table 2 Mechanical Properties of Al 7075 [15] [16].....	10
Table 3 Johnson Cook Constants for Al7075[17].....	11
Table 4 Methodology Flow Chart.....	12
Table 5 Design of Experiments.....	13
Table 6 Parameters incorporated in Abaqus	24
Table 7 Graph in-between Time and Forming Forces (Case1).....	31
Table 8 Graph in-between Time and Forming Forces (Case2).....	33
Table 9 Graph in-between Time and Forming Forces (Case3).....	35
Table 10 Graph in-between Time and Forming Forces (Case4).....	37
Table 11 Comparison with Experimental	37

List of Equations

Equation 1 Johnson Cook Equation [17]	11
---	----

CHAPTER 1: INTRODUCTION

To make thin-walled precision tubes over a rotating mandrel, the incremental metal forming technique known as "Flow forming" uses one or more rollers. While the metal is being pushed axially, the mandrel's internal diameter remains constant. Preforms, also known as initial blanks, may either be shaped like a cup or like a sleeve. Deep drawing, spinning, or forging may all be used to create the preform, which is then machinable. Preform metal is flexible because of the rollers' focused, strong compressive stresses. These compressive stresses cause the material to thin down the wall and mold to the mandrel's shape.

1.1 Background

Forming process are existent since the industry made significant advancement in the manufacturing technologies. Initially the metal spinning process was used to make the round cylindrical parts. One of the earliest chips-less forming techniques is metal spinning, although over time, deep drawing and ironing have gained ground on this technique. CNC machines are now often employed in the production of high-quality items. Recently, spinning has had a revival, emerging into a versatile method for producing lightweight components. Near-net shape manufacture of thin sectioned lightweight components is becoming more popular in modern industries because to the inherent advantages of this method, such as reduced forming loads and easy tooling [1].

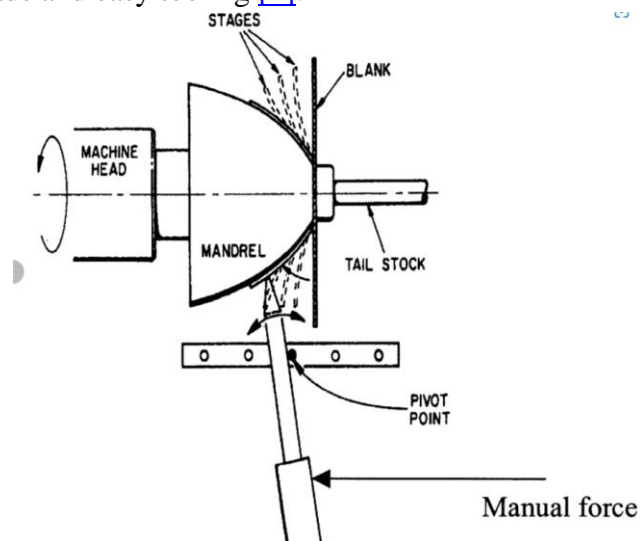

Figure 1 Conventional Spinning Process [1]

Precision metal spinning is still used in the industrial spinning sector today, along with flow forming, a closely related technique. Flow forming is a specialized kind of spinning. Spinning was done manually on devices like a basic turning lathe until the 1950s. The amount of deformation that could be achieved was, by today's standards, limited due to a lack of controllability and a poor tool load capacity. Shear forming and flow forming processes were made viable and developed, however, with the introduction of spinning machines with mechanical propulsion.

Thicker sheets needed to be rolled to produce components with better dimensional precision later in the middle of the 20th century. As a result, spinning machines started to take on new forms and varieties that had increased power and automation. The aviation and aerospace industries in nations like the UK, USA, Germany, and Sweden were one of the driving reasons behind this growth. Components for rocket nose cones, gas turbine engine parts, and dish aerials are examples of the kind of components often manufactured by mechanically driven spinning machines, that were actually the flow forming process. So, as a result better parts with uniform dimensional accuracy were formed and ultimately helped in improving the overall manufacturability of components.

1.2 Aims and Objective

The aim and objective of this research is to develop a thermomechanical FEA model for flow forming of Al 7075. The main goal will be to perform simulations based on changing the feed rates and mandrel speed. The effect will be studied and further compared with the experimental results.

Also, the effect of flow forming forces particularly the axial, radial and circumferential forces will be observed and compared with the experimental results.

The two parameters considered for this study is

- 1. Feed Rate**
- 2. Mandrel Speed**

The model for flow forming will be prepared in Abaqus Explicit software. The technique will be first validated with the already carried out simulation for different material. And then material properties of AL 7075 will be inserted and simulation results will be compared. The simulation will give the Von misses effect and flow forming forces. The defects produced during experimentation will also be explained using the simulated model to predict the failure limits. The results will further help and forecast best suitable parameters for the flow forming using the Aluminum alloy 7075.

CHAPTER 2: LITERATURE REVIEW

2.1 Flow Forming Process

As a metal forming technique, flow forming is progressively being employed to produce axisymmetric engineering components in small to medium batch sizes. A locally plastic deformation technique called flow forming is used to create seamless tubes with thin walls and very accurate measurements. These are all essential in the vehicle industry because they enable consumers to optimize design, decrease weight, and lower costs. Cu, Mg, Ti, and other hard-to-deform materials are primarily utilized for this, including alloys. [2]

2.2 Types of Flow Forming Process

In most cases, the process of flow forming may be broken down into two distinct categories. that is, Forward Flow Forming and Backward Flow Forming respectively. In forward flow forming, the roller moves and the material extrudes in the same direction. While in the backward flow forming, the roller moves and the material extrudes in the opposite direction. Both the strategies are used in producing the thin seamless parts.

Both the processes, used the rigid roller and mandrel while the preform extrudes following the shape of the mandrel. The roller moves over the perform in repetitive manner until the desired shape is obtained keeping the constant pressure and forces to obtained uniform dimensional accuracy and smoothness. [3]

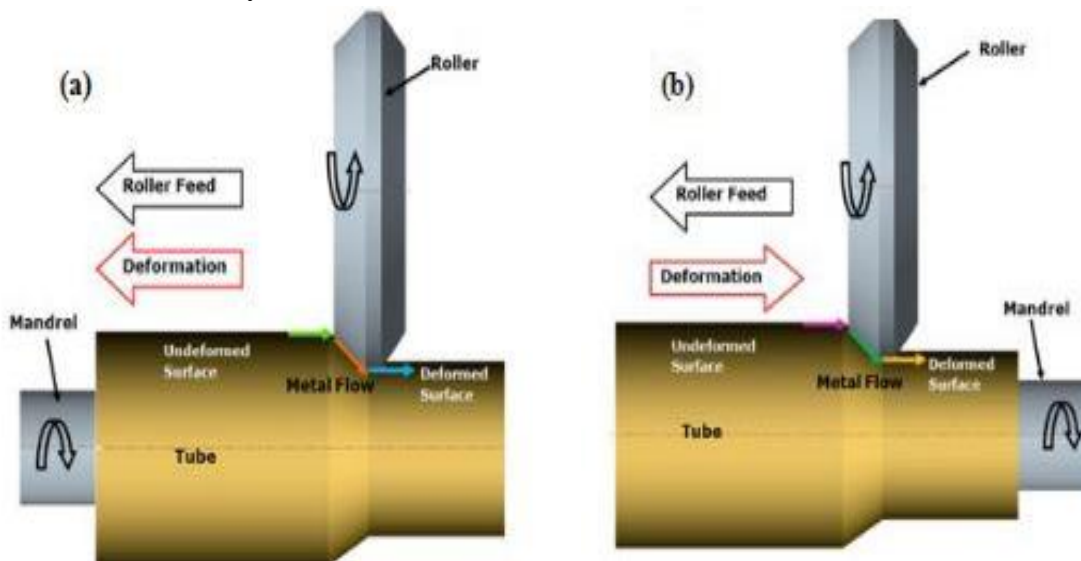

Figure 2 Forward and Backward Flow Forming Process [3]

Research was carried out to compare both the forward and backward flow forming techniques. Understanding the pressures and strain distributions encountered throughout the process is essential for effective and successful product manufacture since flow forming is a non-linear plastic deformation process. Even if the process of plastic deformation is nonlinear, it is still impossible to anticipate the distribution of force and strain. The FEA based tool Abaqus was used to develop the model and the material was AA 6063. The effects of flow

forming forces, von misses and equivalent plastic strain on both the strategies was observed. Along with the strain distribution in the length and thickness, the axial, radial, and circumferential forces that were acting throughout the process have been acquired and presented. In forward flow forming, it was discovered that the axial and radial forces are much greater than in backward flow forming. When flow is formed in a backward direction, there is a greater circumferential force. In addition, the plastic strain distribution was found to be greater along the thickness in forward flow forming, but in backward flow forming, it was found to be higher along the length. Before beginning real production, it will be easier to establish a viable approach for a variety of material and process circumstances. [2]

2.3 Advantages of Flow Forming Process

The fundamental benefit of the process is precise and accurate production with increased mechanical characteristics. Other benefits include efficient material use, chip-free manufacturing, quicker processing times, and elastic production processes. The thickness of the wall may be precisely regulated. As a consequence, the thickness of the wall is uniform. Flow forming's control of tolerances to within the range of machinable components extends throughout the component's length, across a variety of shapes and wall thicknesses. [2]

2.4 Applications of Flow Forming Process

Various researchers have mentioned the significant applications of Flow Forming Process. [2] [3] Due to its high accuracy and precise production it is widely used in the making

- a. Aircraft Fittings
- b. Automotive Industry (Tire Rims, Shafts, Gears)
- c. Regulating Valve Parts
- d. Aerospace and Defense Industry (Rocket Motor Case, Rocket Nose Cones, Missile Casings, Cartridge Casing)
- e. Gas Turbine Components
- f. Pressure Gas Bottles
- g. Tubes and Closed end cylinders for Pharmaceutical, Chemical, Nuclear, Food and Beverage Industries.

2.5 Parameters in Flow Forming Process

The operational factors that have the most impact on the forming process for the material Al 6063 are discussed in this study. The factors that had the most influence was discovered to be feed rate and friction coefficient. It was also discovered that the axial force was the greatest force generated. Radial force was the second most dominating. The least prominent force was the circumferential force. Many variables influence flow forming, including operation settings, material qualities, and the geometry of the rollers themselves. Controlling the operating variables is simple, but manipulating the material qualities and the geometrical parameters of the rollers is more challenging. because different batches and lots of

the same material may have different material qualities. Furthermore, experimenting with different roller configurations is challenging because to the increased material consumption and inventory costs associated with using several rollers and workpieces. Since the cost of raw materials for the workpiece and the tooling may be reduced by changing the operating conditions, a FE-based tool is preferable. [4]

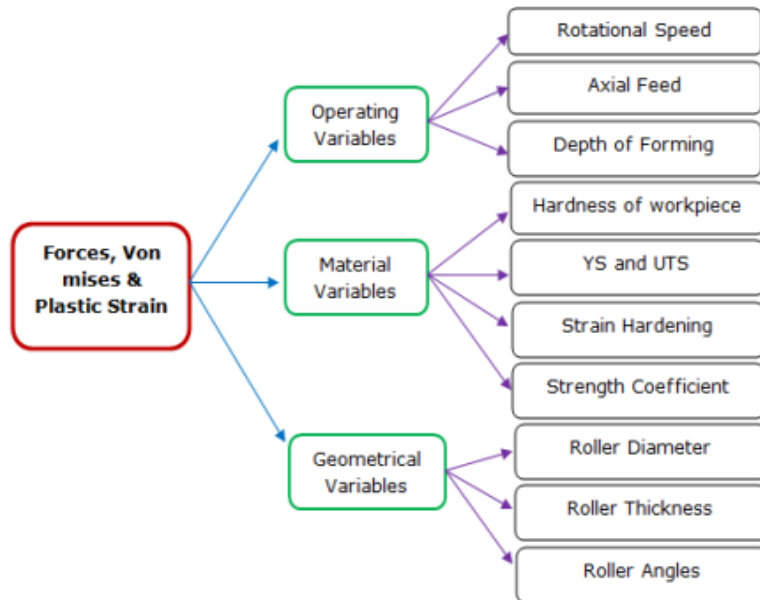

Figure 3 Parameters effecting Forces, Von Misses & Plastic Strain [4]

In order to investigate the consequences of employing miraging steel MDN 250, a backward flow forming was carried out using the explicit programmed Abaqus. Researchers have investigated the effects that flow forming process variables like feed rate and reduction ratio have on stress/strain distribution as well as roll forces. When the feed rate is raised from 1 millimeter per second to 2.33 millimeters per second, there is a 7 percent rise in the effective plastic stress. If the reduction ratio is increased from 23 percent to 33 percent, then the corresponding plastic strain will increase by 72 percent. Adjusting the feed rate, reduction ratio, and roller Z attack angle are the three variables that have the most impact on the tube's ability to maintain its circular shape. It has been shown that, out of all the process parameters, the reduction ratio is the one that is the most critical. In addition to this, it was found that the accumulation of material is to blame for the significant magnitude of equivalent strain that may be seen near the front of the roller. [5]

Aiming to reduce the axial force and material buildup during flow formation, the author carried out the investigation. A strong axial force was measured over the course of the research. Bulge and buildup of material beneath roller. This is why FEM modelling was utilized successfully to anticipate the resulting forms, specifically the buildup of material and the spring back. The axial force rises as the attack angle widens, resulting in material accumulation. [6] Experimental study was carried out for AISI 321 Steel tube for the flow forming process. The setup was established by the changes in Lathe machine. The roller and mandrel were fixed into

the lathe machine setup and preform of AISI 321 was introduced into the process for its extrusion. The main goal was to study the parameters effecting the quality and dimensional precision of the tubes. Feed rate, depth of cut and attack angle were the parameters that were considered for the experiment. It has been discovered that the depth of cut is the most significant process parameter that affects the degree to which an object is out of round. As the depth of cut is increased, the out-of-roundness will decrease, but it will grow as the feed rate and roller attack angle are increased. [7]

Experiments were performed by the author on annealed AA6082 alloy tubular preforms in order to generate thin-walled seamless tubes using a CNC flow forming machine with a single roller. These tubes were then tested. For the purpose of this investigation into the manufacturing process, the roller radius, the mandrel speed, the roller feed, and the thickness reduction were selected as the process parameters to investigate. The following characteristics of flow-formed tubes have been prioritized for selection: ovality, mean diameter, thickness variation, and surface quality. Research has been carried out to study the effect that these process parameters have on the functional aspects of flow-formed tubes as well as the surface quality of these tubes.

It was discovered that the radius of the roller had a substantial influence. When the radius of the roller is increased, the tube will become more oval in shape. When the speed of the mandrel is slowed down, the surface of the tubes produced will have scratch marks. The surface imperfections are covered up as the speed rises, which resulting in a smoother finish. The finish is excellent up to a certain limit when the speed is increased to a higher value; however, the finish deteriorates with further increases in speed owing to the vibrations that occur at greater speeds. The ovality of the flow-formed tubes first rises when the feed is added, and then it begins to diminish. Deformation in the radial direction is brought on by lower feed rates., which leads to increased ovality in the finished product. It has been noted that producing tubes with desirable surface characteristics may be accomplished by combining a high speed with a reduced feed rate. [8]

2.6 Forces in Flow Forming Process

In present work, an experimental examination of the flow forming of Al7075-O preform was explored. Flow forming is a process in which the material is formed by flowing. During the course of this inquiry, the thickness reduction was altered on many occasions, and its influence on the flow forming forces as well as the increase in temperature of the work piece was analyzed. A dynamometer was used in order to get information on the forming forces. The formation of the flow is associated with a complex state of stress, which in turn produces a complex state of force. In the course of the procedure, the material is subjected to both compression and elongation as it passes under the roller. Because of this, the forces may be broken down into three distinct types: the axial force, the radial force, and the circumferential force. The stretching of the material that had been distorted as a result of the axial movement of the roller was what ultimately led to the generation of the axial force. The compression of the material that was located underneath the roller was the source of the radial force that was created. The material that has been deformed goes through a rotating motion as a result of the

rotation of the mandrel, which is what gave origin to the circumferential force. Based on the results of the real-time force measurement, it was determined that the axial force is the most significant contributor to flow forming, followed by the radial force. When compared to the other forces, the contribution of the circumferential force to the formation of the flow is the least significant. This is most likely the result of a smaller deformation zone as well as a slower mandrel speed. [9]

In this research the forces during the flow forming process were studied using the FEA. Al 6063 was the material used in this investigation because of its superb corrosion resistance and low weight. Along with flow forming forces, variables such as the roller's rotating speed, the depth of the form, and the axial feed were taken into account. Among the other forces, axial feed was determined to be the strongest. The second dominant was the radial force and lastly the radial force. It was also found that the rotational speed has a high influence on the forming forces. [10]

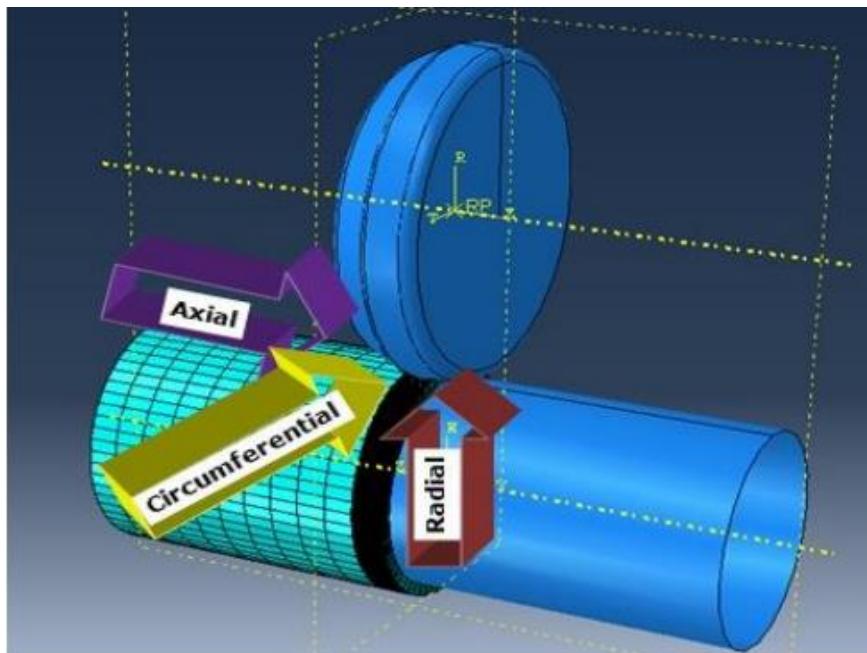

Figure 4 Forces During Flow Forming Process [10]

2.7 Foundation Paper for Research

Flow formation of Al7075 is the subject of this study. Flow formation forces are affected by feed and mandrel speed variations, which have been studied in detail. Changes were made to a traditional lathe machine in order to conduct the experiment.

During the flow-forming process, rollers are used to create a distortion in the preform. Throughout the whole of this process, a solid mandrel was used to support a hollow preform. The mandrel was propped up by the headstock of the instrument. After that, one of the forming rollers will pass it over the item of work being done. It is through this gap that the distorted material flows when the preform is deformed. It was decided that the roller attack and relief angle would be 30 degrees each. The preform was extruded using forward flow forming. With a feed rate of 0.04 and 0.08 mm, the trials were carried out at speeds of 250 and 420 RPM.

A Lathe dynamometer was used to measure the flow formation forces in three different directions: axial, circumferential, and radial. A SAE 4340 alloy mandrel was used. According to the findings, changing the feed rate had a greater impact on average forces than did altering the mandrel rpm.

As feed is increased, the forces on all three dimensions grow simultaneously. The forces are also increased when the mandrel revolutions per minute (rpm) are increased; however, this increase is not as significant as the rise in forces that occurred when the feed rate was altered.

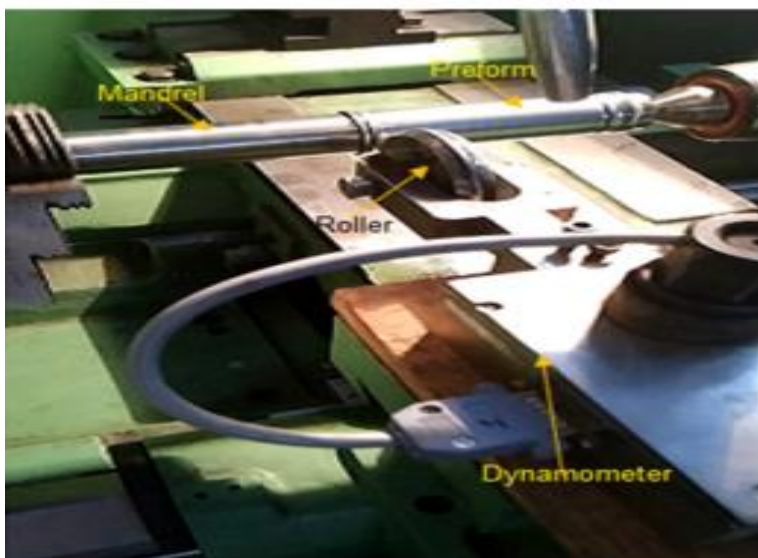

Figure 5 Experimental setup for Flow Forming [11]

Dimensions of Preform			Dimensions of roller			Feed rate	Reduction	RPM (Mandrel)
Internal Diameter	Thickness of wall	Original length	Diameter	Attack angle	Relief angle			
31 mm	1.5 mm	40 mm	63 mm	30°	30°	0.04 mm, 0.08 mm	0.5 mm	250, 420

Figure 6 Process Parameters During Experiment [11]

Chips, fractures, and ruptures were also detected throughout the testing. There was a problem with either the roller design or the bearing choices that resulted in chips. When the roller is

loaded, it continues to slide over the workpiece. In addition, the cracks formed as a result of material inhomogeneity and a probable increase in stress at the roller front. [\[11\]](#)

The experimentation of AL 7075 alloy for flow forming, is the main foundation paper for this Present investigation. Many researchers have worked on different materials both experimentally and on several fea tools. However, No FEA modelling of AL7075 using ABAQUS has been reported yet to best of Author knowledge. So based on this experimentation, the FEA model will be developed and the effect of forming forces and possible defects occurred during experimentation will be studied.

2.8 Simulation Approach using ABAQUS

The ABAQUS software was used so that the simulation procedure could be carried out. In order to complete the finite element analysis, firstly assign appropriate component types when creating solid Parts. This is the first step. Then second step is to define the Material Models and then to allocate the material to the appropriate section. In step three, you will position the tool by utilizing the translate option once you have created instances in the assembly. Create stages, specify interactive attributes, contact control, and boundary conditions in the fourth phase of the process.

In the fifth step, when the task has been created and submitted, the results are analyzed by utilizing the visualization window.

The modelling of the flow forming process is challenging because of the localized deformation that occurs because only a small portion of the workpiece is in contact at any given time, the rotation of the workpiece causes a change in volume, and fine meshing can only be implemented using a three-dimensional model. Therefore, in order to save time and cut down on the cost of calculation, the roller and the mandrel should be regarded to be rigid, whereas the workpiece should be considered a deformable body. It is important to provide axial feed and rotation to the rollers.

The study also explores whether or not Abaqus Explicit dynamics need to be regarded rather than implicit dynamics, given that the process need to follow a quasi-static response, and its K.E should be lower than 5 percent of the total internal energy. Because the implicit code in Abaqus demands a significant amount of processing time, convergence is not guaranteed for nonlinear flow forming models that are very discontinuous. Consequently, because this is the case, explicit dynamics is the most appropriate method, and its mass scaling will both save time and solve effectively. [\[12\]](#)

2.9 Material Properties for AL 7075 Alloy

Due to its low density, high strength, ease of processing, corrosion resistance, and other exceptional features, aluminum and its alloys are among the most essential and commonly used materials in the world today. In the aerospace and defense sectors as well as in general, the 7xxx family of aluminum alloys is the preferable material because to its great strength. Zinc is the major alloying element in Aluminum 7075 Alloys. In cold working operations, they are frequently utilized and suited for forming workpieces. [\[13\]](#) [\[14\]](#)

Elements in AL 7075	Percentage (%)
Copper Cu	1.2-2
Chromium Cr	0.18-0.28
Manganese Mn	0.3
Magnesium Mg	2.1-2.9
Silicon Si	0.4
Titanium Ti	0.2
Zinc Zn	5.1-6.1
Iron Fe	0.5
Aluminum Al	Balance

Table 1 Aluminum 7075 Chemical Composition [\[15\]](#)

Density	2.81 g/cc
Hardness, Vickers	175 HV
Ultimate Tensile Strength	572 MPa
Modulus of Elasticity	71.7 GPa
Thermal Conductivity	130 W/m-K
Melting Point	635° C
Inelastic Heat Fraction	0.9

Table 2 Mechanical Properties of Al 7075 [\[15\]](#) [\[16\]](#)

2.9.1 Johnson Cook Model Properties of AL 7075

The investigation carried out to calculate the constant for Johnson Cook for Al 7075. The constitutive models help in accurately predicting the flow stress. Physical, phenomenological, and artificial neural network models are all examples of constitutive models used to predict high-temperature material behavior. Phenomenological models, on the other hand, have fewer constants that must be determined, and their calculation procedure is less complicated and time-consuming than in physically based models. Many phenomenological equations, such as the Johnson–Cook equation, may be used to characterize constitutive behavior. There are less constants and fewer experiments required to compute the constant values of the JC model, which explains alloy deformations at extreme temperatures and high strain rates, as compared to other constitutive models. [17]

The formula for Johnson cook is as following,

$$\sigma = (A + B\varepsilon^n)(1 + C \ln \dot{\varepsilon}^*)(1 - T^{*m})$$

Equation 1 Johnson Cook Equation [17]

Where,

A (Yield Stress)	198 MPA
B (Hardening Modulus)	268 MPA
n (Hardening Coefficient)	2.43
m (Thermal Coefficient)	0.49
C (Strain Rate Sensitivity)	0.26
Tm (Temperature Melting)	635° C
Tr (Temperature Reference)	1° C

Table 3 Johnson Cook Constants for Al7075[17]

CHAPTER 3 RESEARCH METHODOLOGY

3.1 Methodology Flow Chart

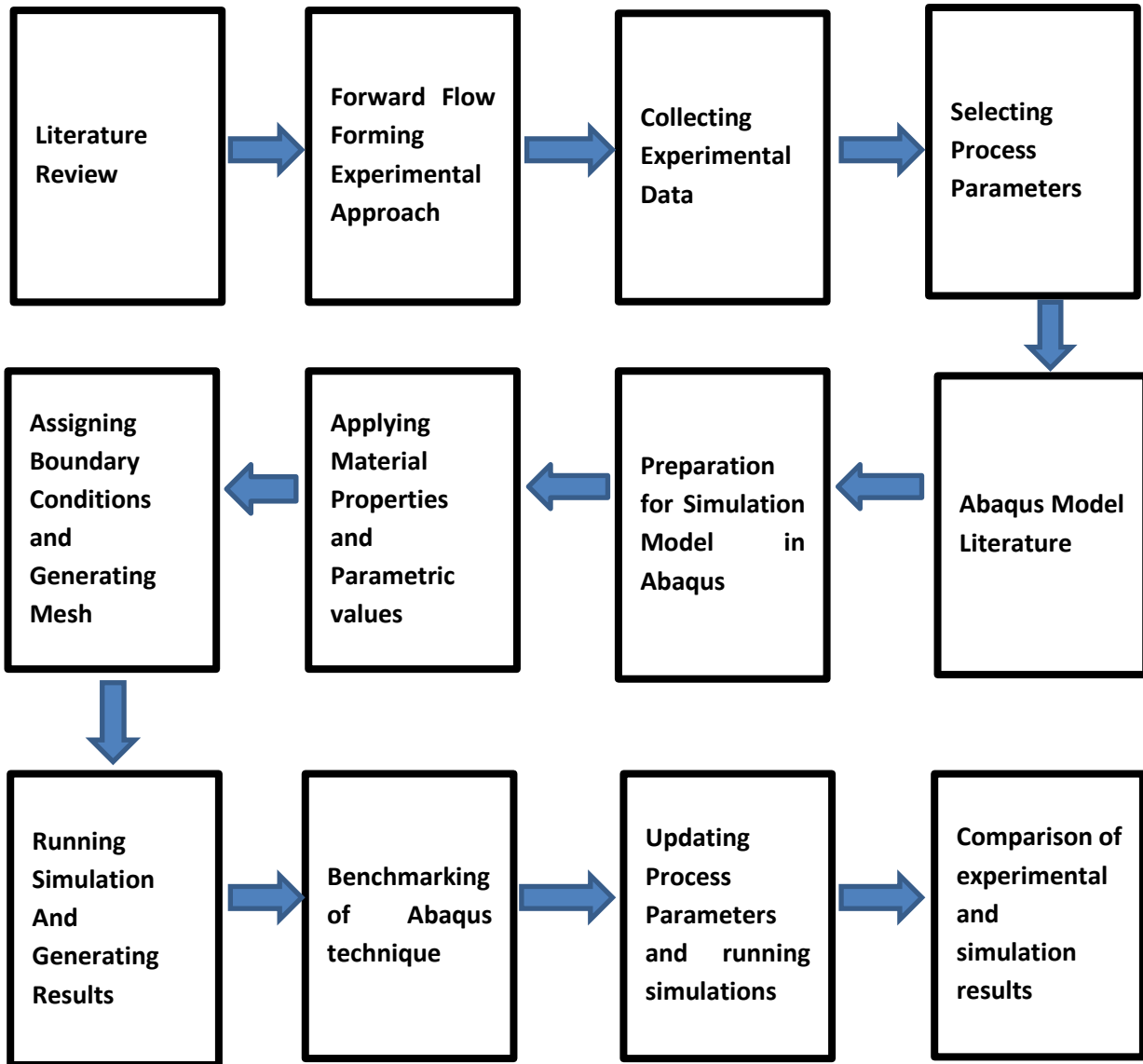

Table 4 Methodology Flow Chart

The investigation on the experimental approach started with the literature review of previous related works done in flow forming. Initially the experimental work based on forming processes, its critical parameters, forming setup and extrusion techniques were studied to have better understanding of procedure. Then based on that the foundation paper, the condition of the experimental setup was analyzed and possible conclusion based on the foundation paper results were understood. Possible causes highlighted during the experiment were highlighted. Based on the FEA approach, further literature was carried out to learn and understand the modelling of flow forming using the ABAQUS software. Once the literature view concluded, the modelling in Abaqus was started. Initially the flow forming process was modelled in

Abaqus by creating the roller, preform and mandrel and then creating the assembly from it. Then the material properties and boundary conditions were applied. Once the setup was completely modelled and parameters applied, the simulations were performed. In order to validate the setup, the simulations result of previously done literature simulations were compared by inputting their boundary conditions. The results were benchmarked. Now the foundations paper boundary condition was applied to the model and the simulations were performed. Lastly the results were compared with the experimental work and conclusions were made based on experimental and fea results.

3.2 Parameters Selections

Following are the parameters selected for this Study

3.2.1 Feed Rate

Despite the fact that the influence of feed rate has been spoken about in great detail in the reviewed literature. Increases in feed rate result in increases in all three of the forming forces: axial, radial, and circumferential forces. Feed rate has a greater influence on the formation of forces than any other factor.

3.2.2 Mandrel Speed

Mandrel speed also has significant effect on the forming forces. However, its change in effect is less as compared to the feed rate change.

3.3 Design of Experiments

No of Simulations	Feed Rate	Mandrel RPM
Simulation 1	0.08	250
Simulation 2	0.08	420
Simulation 3	0.04	250
Simulation 4	0.04	420

Table 5 Design of Experiments

CHAPTER 4 MODELLING IN ABAQUS

4.1 Model Development for Al 7075 O Alloy

In order to perform the FEA analysis, A thermomechanical model of flow forming was developed in ABAQUS. Abaqus is an advance FEA tool that is used to perform simulations that are nonlinear and contain high deformations. It was can solve the parameters based on its equations. As suggested by the literature [12] the methodology to model the forward flow forming has been selected. Explicit Dynamics was used to simulate flow forming. While experimental setup and parameters for this research has been taken from [11] i.e., Foundation paper.

4.1.1 Part Modelling

a. Roller

Roller was modeled in Abaqus as 3D Rigid Part with the diameter of 63mm and attack and relief angle of 30°

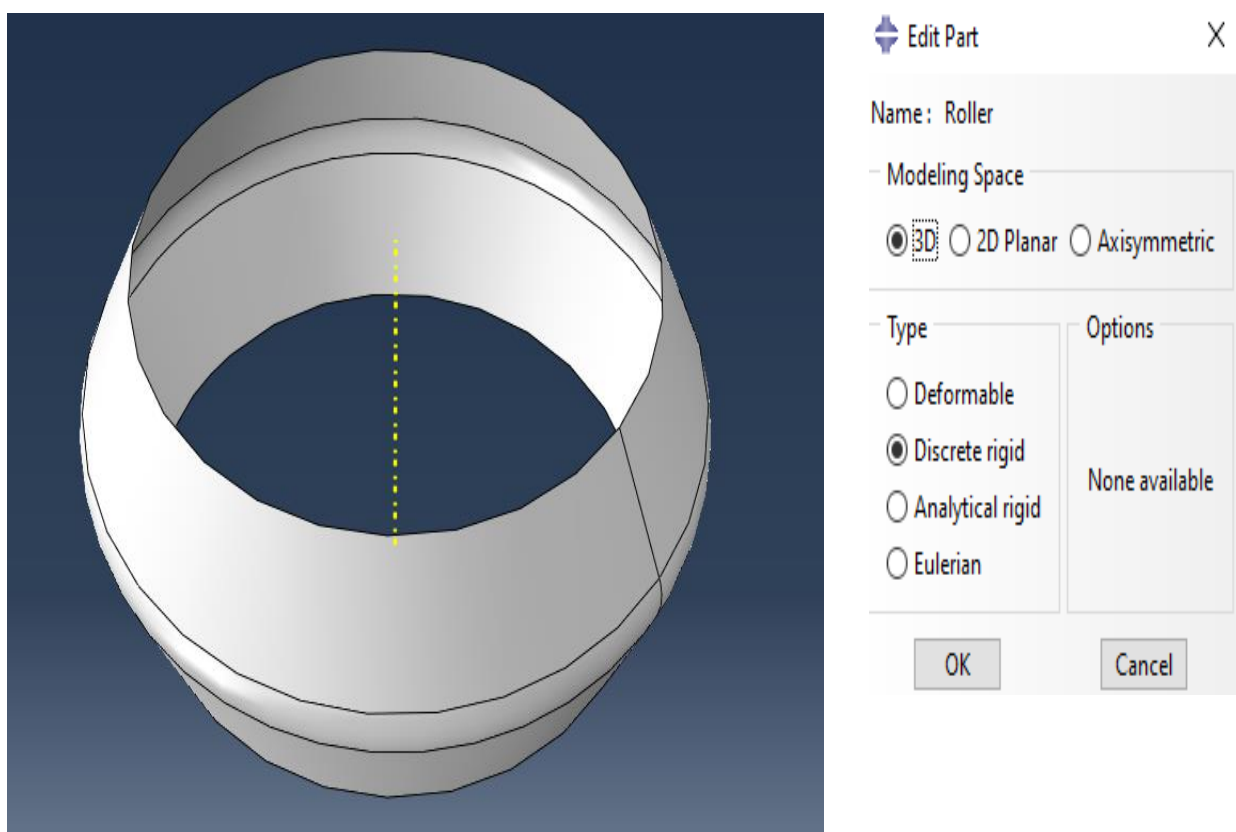

Figure 7 Modelling of Roller in Abaqus

b. Mandrel

The mandrel was modelled in Abaqus as 3D Rigid part. As the preform will deform over it so it is made rigid with the size of radius 15.5mm as that of preform. The length of the mandrel was kept double as that of preform. i.e., 80mm

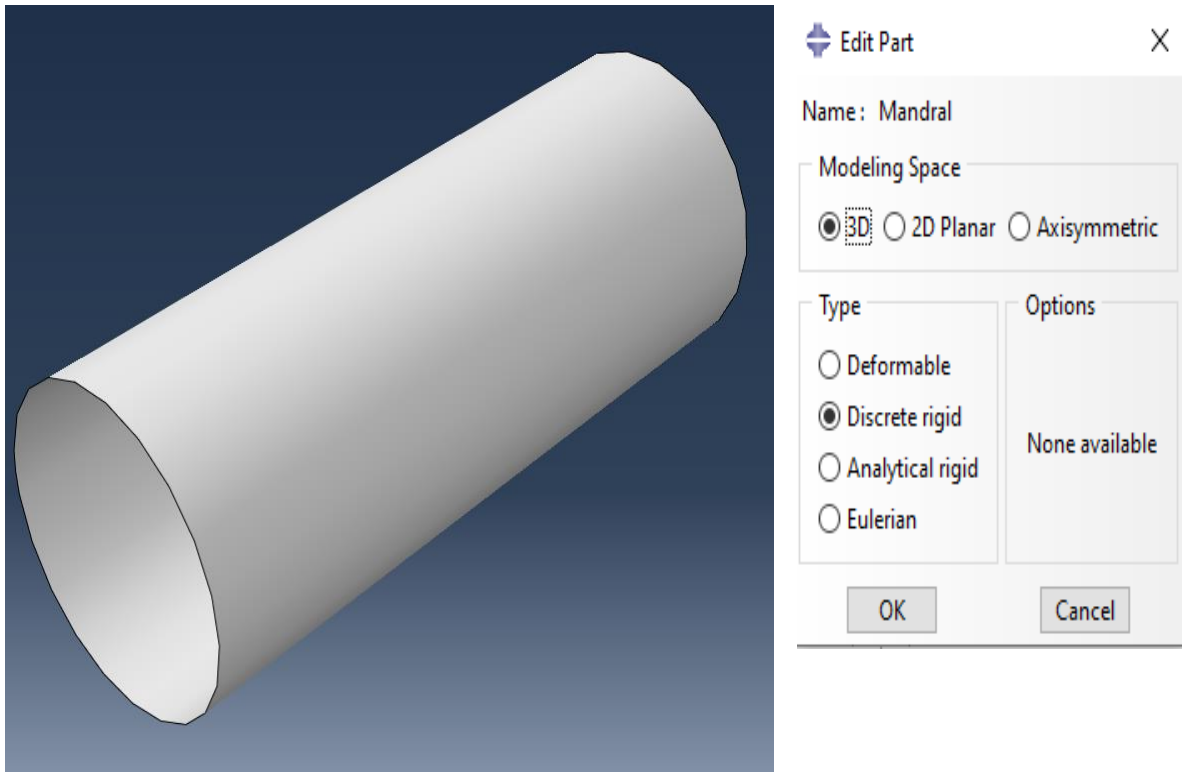

Figure 8 Modelling of Mandrel in Abaqus

c. Preform

The Preform is the main Part in flow forming on which the result of the simulations depends. Based on the literature, in order to study the forces and other effects it is always modelled as deformable solid. The preform was modelled with internal diameter 31mm with addition of thickness 1.5mm. The length of the preform was specified as 40mm.

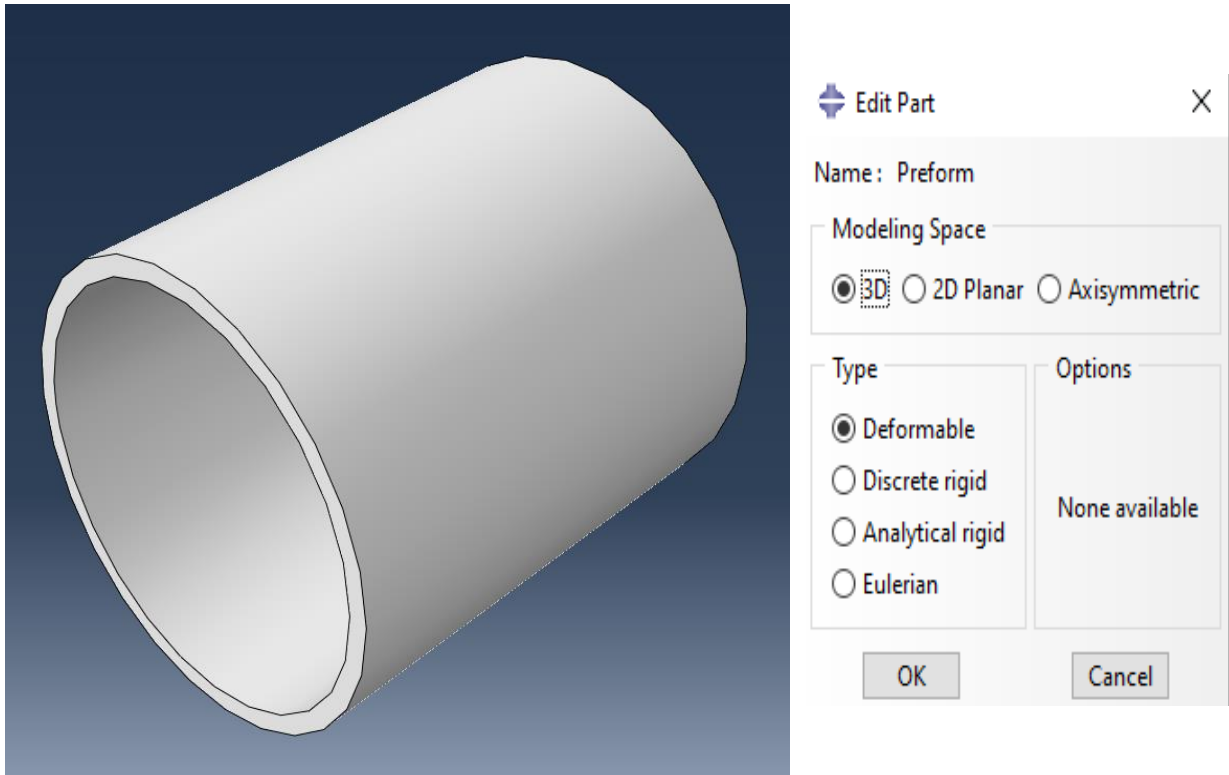

Figure 9 Modelling of Preform in Abaqus

4.1.2 Material

As the roller and mandrel are made rigid so the material is not assigned to them. The preform has been assigned a material property of AL 7075 Alloy. Abaqus has no units. So, care must be taken in properly inserting units. If the geometry is in SI (mm) then all units should be converted into SI (mm). The units for this research were kept in mm

Quantity	SI	SI (mm)	US Unit (ft)	US Unit (inch)
Length	m	mm	ft	in
Force	N	N	lbf	lbf
Mass	kg	tonne (10 ³ kg)	slug	lbf s ² /in
Time	s	s	s	s
Stress	Pa (N/m ²)	MPa (N/mm ²)	lbf/ft ²	psi (lbf/in ²)
Energy	J	mJ (10 ⁻³ J)	ft lbf	in lbf
Density	kg/m ³	tonne/mm ³	slug/ft ³	lbf s ² /in ⁴

Figure 10 Units Conversion in Abaqus

So, the properties of Al 7075 were incorporated into the Abaqus with the Johnson cook model in order to accurately predict the forces and stresses acting on the preform.

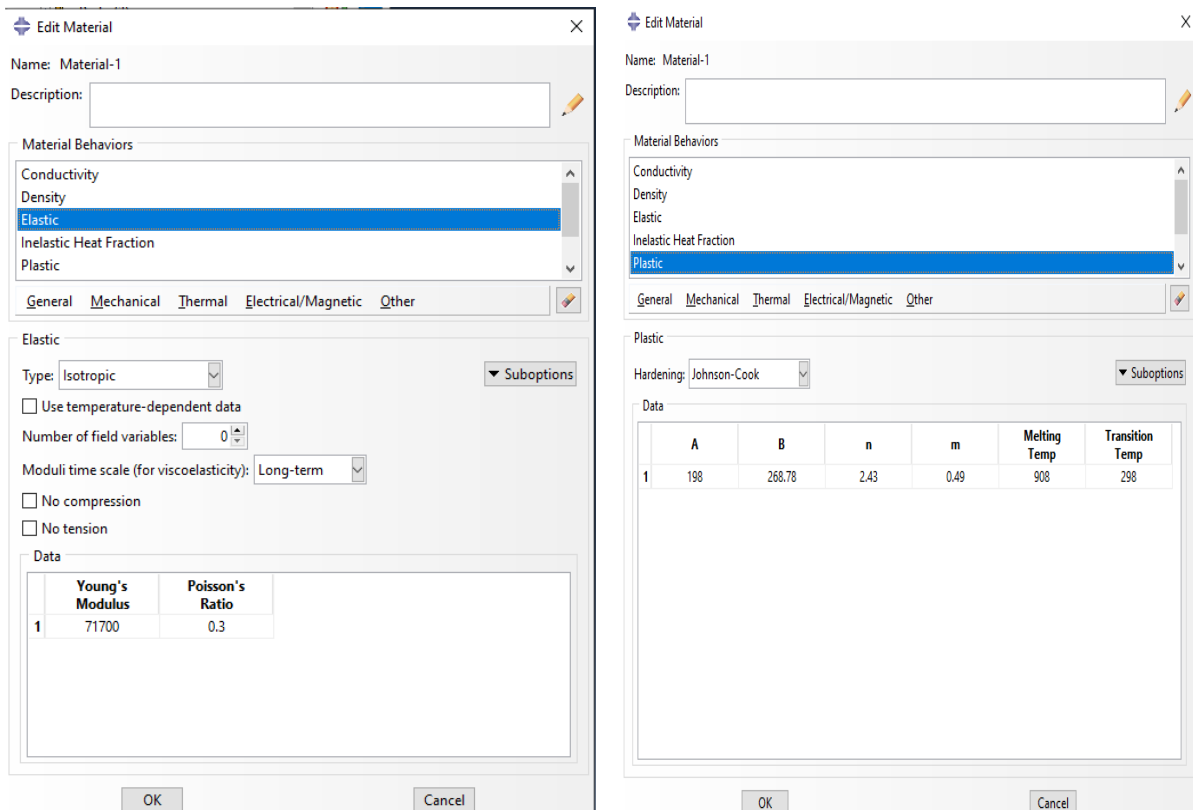

Figure 11 Material Properties of Al 7075 Incorporated into Abaqus

Similarly, all the properties were incorporated into the Abaqus after conversion into SI (mm) units. All the values are referred from literature of Al 7075 material. [\[15\]](#) [\[16\]](#) [\[17\]](#)

4.1.3 Assembly

In the next phase the roller, mandrel and preform are assembled together to create an instance. The mandrel is fixed while the preform is placed on it. The roller is aligned with the preform so that when the roller moves, it can precisely extrude the preform to the desired reduction ratio. According to the experimental setup the roller is just translating and the mandrel is rotating on which the preform is rotating. But in simulations in order to save the computational cost and time, the roller is given the rotation as well as the translation. In this way significant time is reduced as well as the volume of the preform is also controlled. [\[12\]](#)

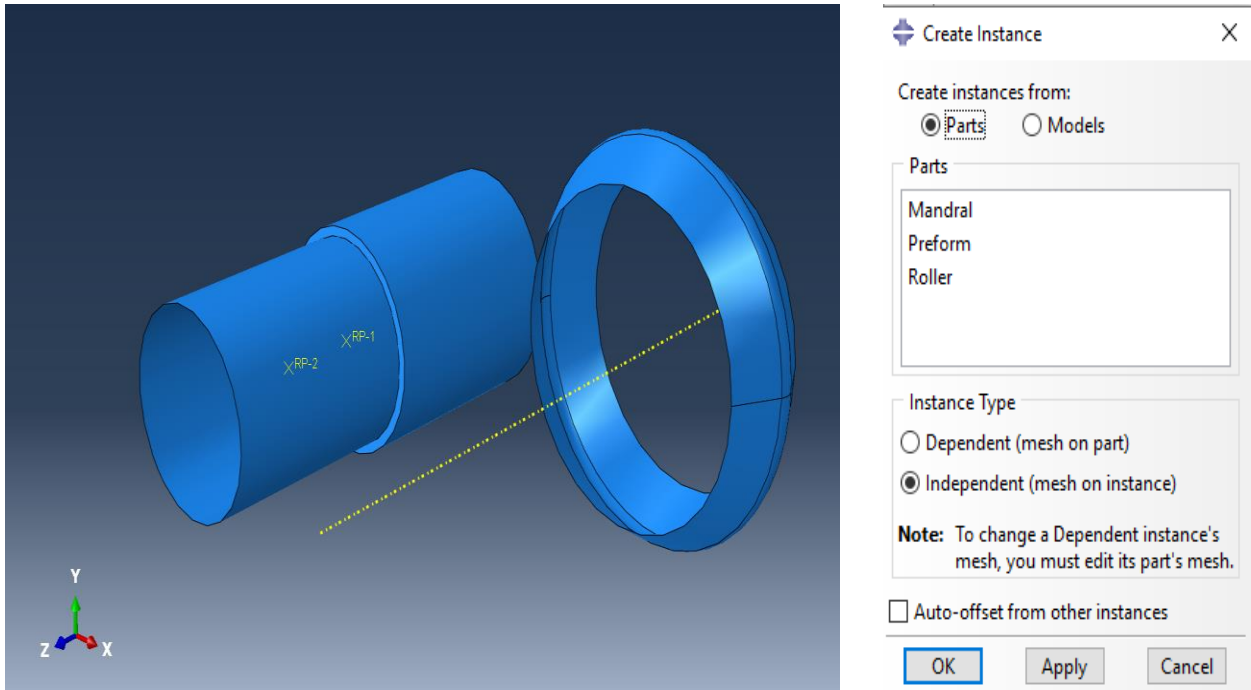

Figure 12 Assembly Creation of Flow Forming Setup in Abaqus

4.1.4 Step

The next phase in Abaqus modelling is defining the step. For the step the explicit dynamic approach was selected. As per the simulation requirement, the roller, mandrel and preform initial and final conditions have been applied.

a. Roller

The roller is given the displacement as well as the rotation in Z direction only. As the roller will move and rotate in z axis it will extrude the preform over the mandrel and process will be completed.

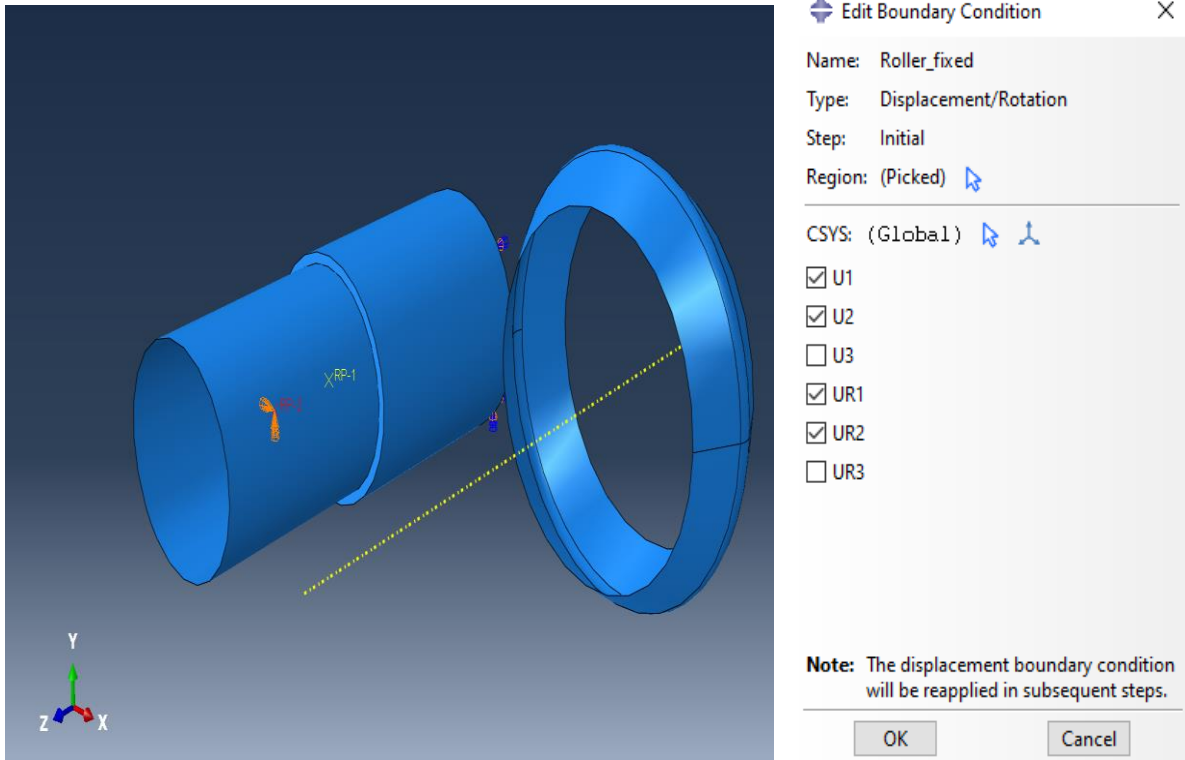

Figure 13 Roller Displacement and Rotation along Z Axis

b. Mandrel

As the mandrel is fixed according to the modelling in Abaqus so it is bound to remain constant in all x, y and z axis displacements as well as rotation. According to the simulation modelling, the preform will place over it and the roller will further move on the preform to extrude it to shape of mandrel. So, it must be fixed in all axis to efficiently and effectively perform the process.

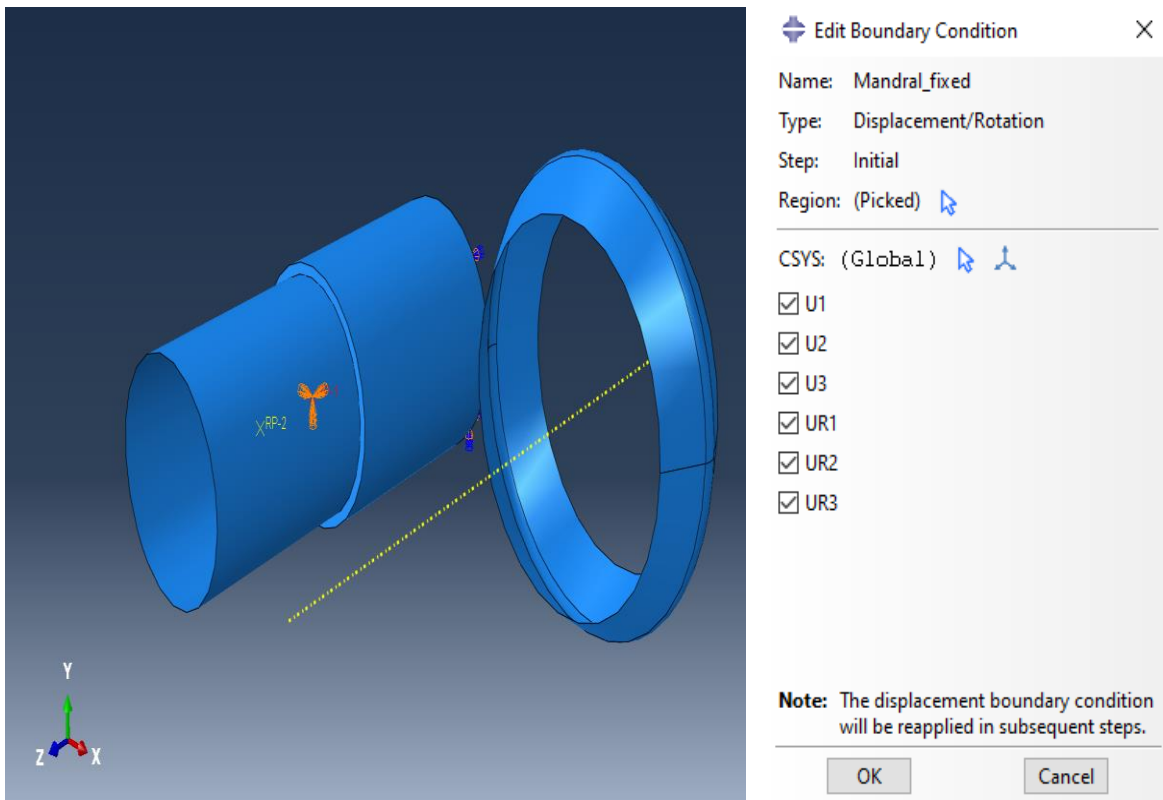

Figure 14 Mandrel Fixed along all Axis

c. Preform

As the preform is a deformable solid, it is placed over the mandrel and the roller will move over it to extrude it according to shape of the mandrel. The preform inner edge is encastered so that the roller can extrude it properly.

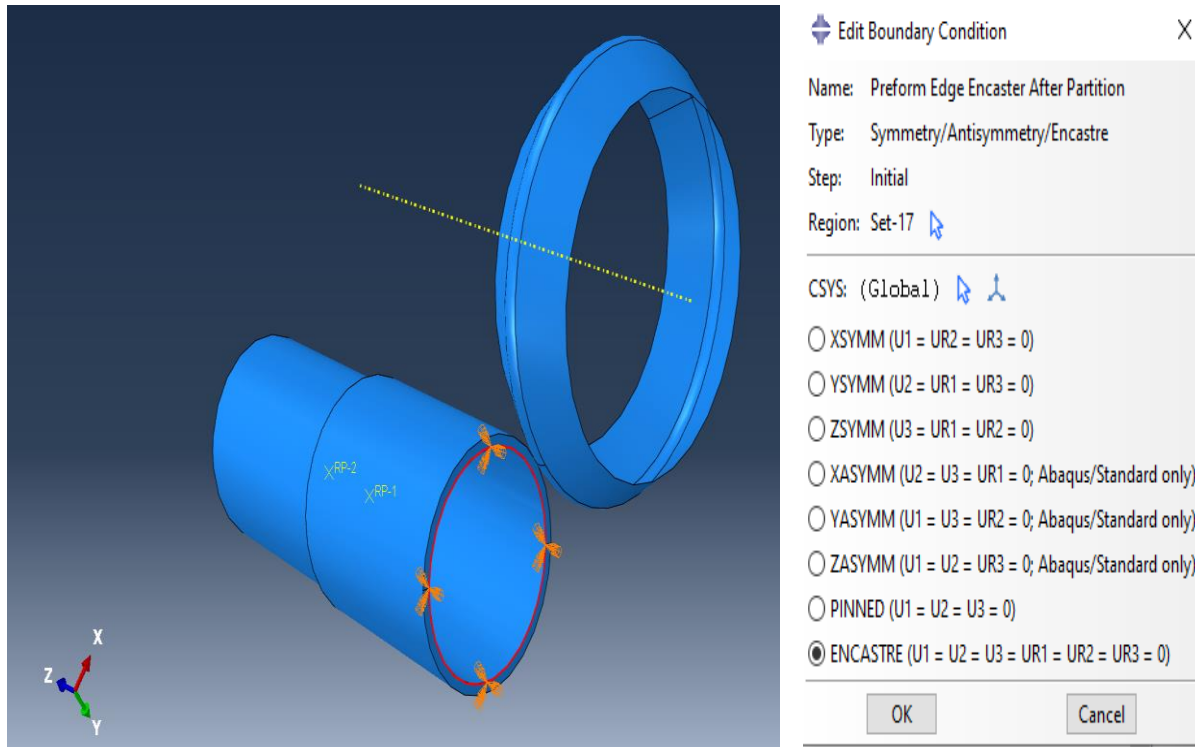

Figure 15 Preform encastered along inner edge

After assigning the conditions to the flow forming assembly, the field and history outputs were inserted. As per the conditions the stresses i.e., Von misses, Plastic strain, contact and reaction forces were inserted. In order to validate the energy conservation and mass scaling parameters, the all energies in the history output are also incorporated into this research.

As the explicit analysis is used so it is very important to check the nature of the process. As flow forming is a high deformation process, the mass scaling should be applied with proper properly. For process to be in following quasi static response, the Kinetic energy should be with 5-10% of total internal energy. If it is following within this limit, the mass scaling factor can be applied. [12]

The mass scaling factor applied in the simulation was 200 which was applied at the start throughout the simulation.

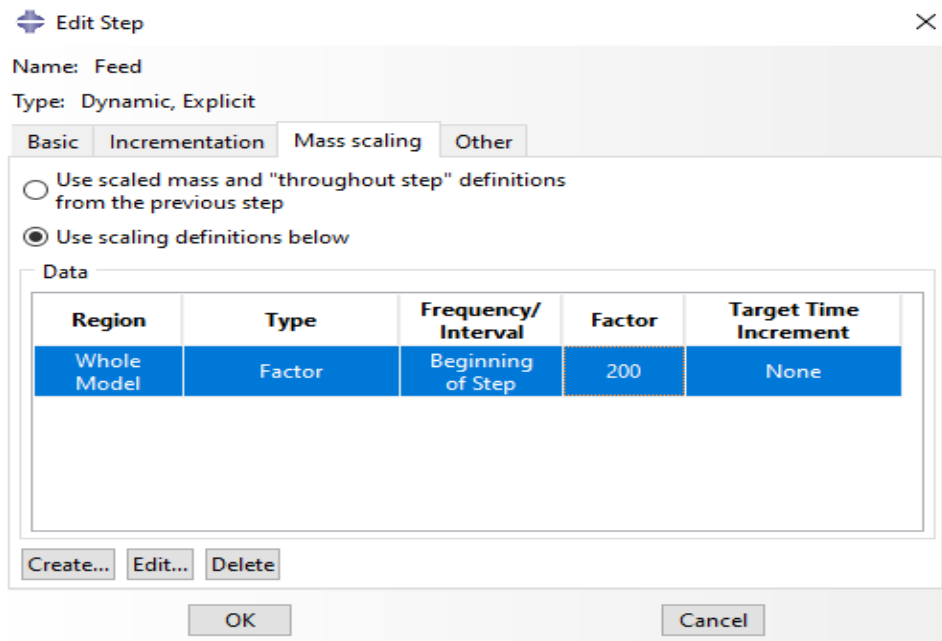

Figure 16 Mass Scaling applied during Simulation

4.1.5 Interaction

The general contact form of interaction was used while the simulation was being carried out. The general contact explicit method was used in each and every area. In the flow forming process, the precise friction coefficient is extremely difficult to measure due to the intricate interaction and coolant, and as a result, a modest friction factor of 0.1 was estimated to exist between the contacting surfaces. This is because the precise friction coefficient is extremely difficult to measure.

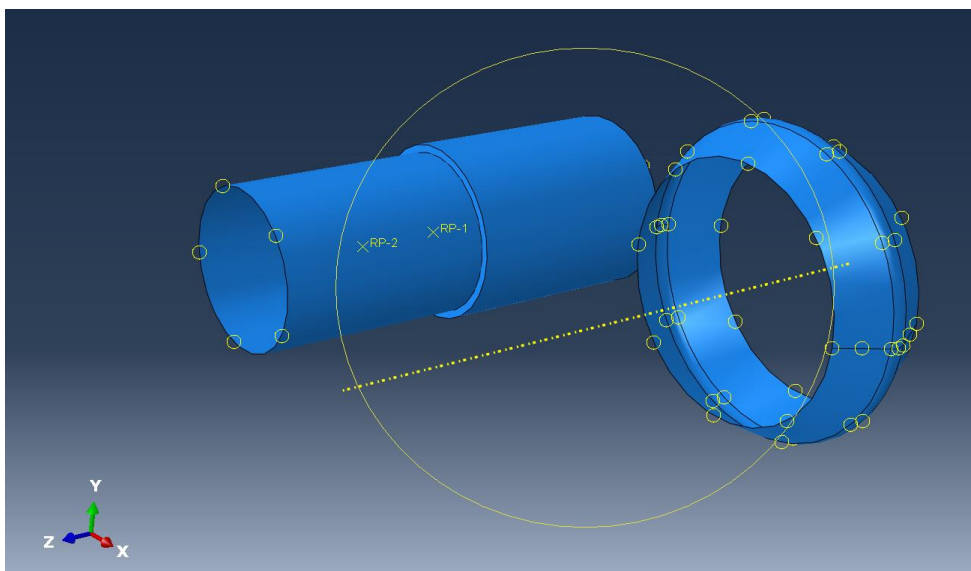

Figure 17 General contact interaction used in Modelling

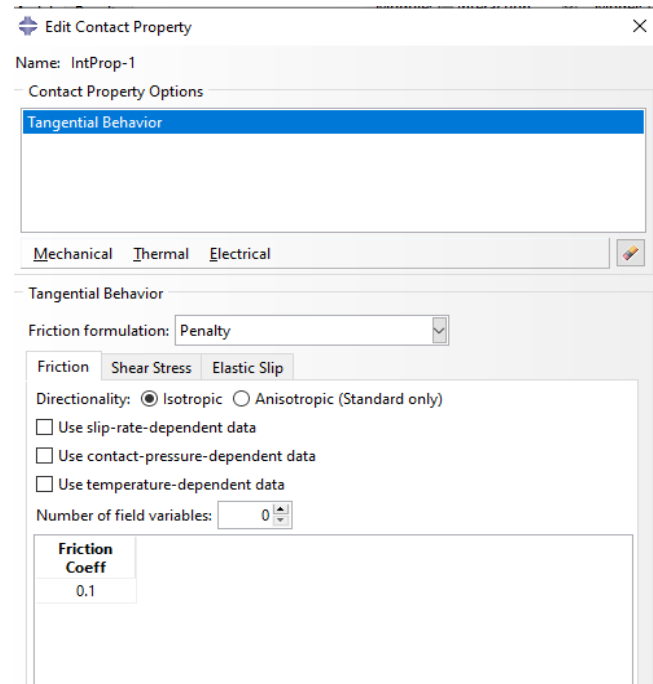
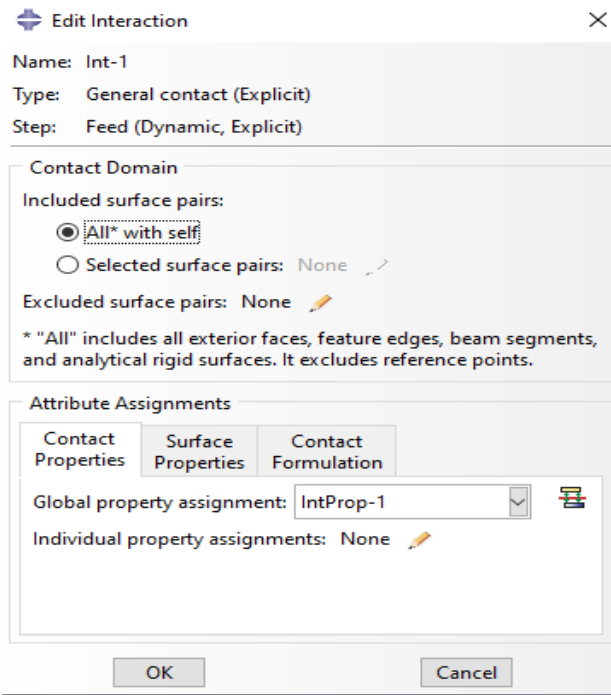

Figure 18 Interaction properties and coefficient of friction

4.1.6 Boundary Condition

Once the boundary conditions of roller, mandrel and preform are incorporated into the Abaqus, the parameters selected during the flow forming process are incorporated. The feed rate and the Mandrel speed. For that purpose, the feed rate and the mandrel speed parameters both are added into the boundary condition of roller as suggested by the FEM modeling in [12]

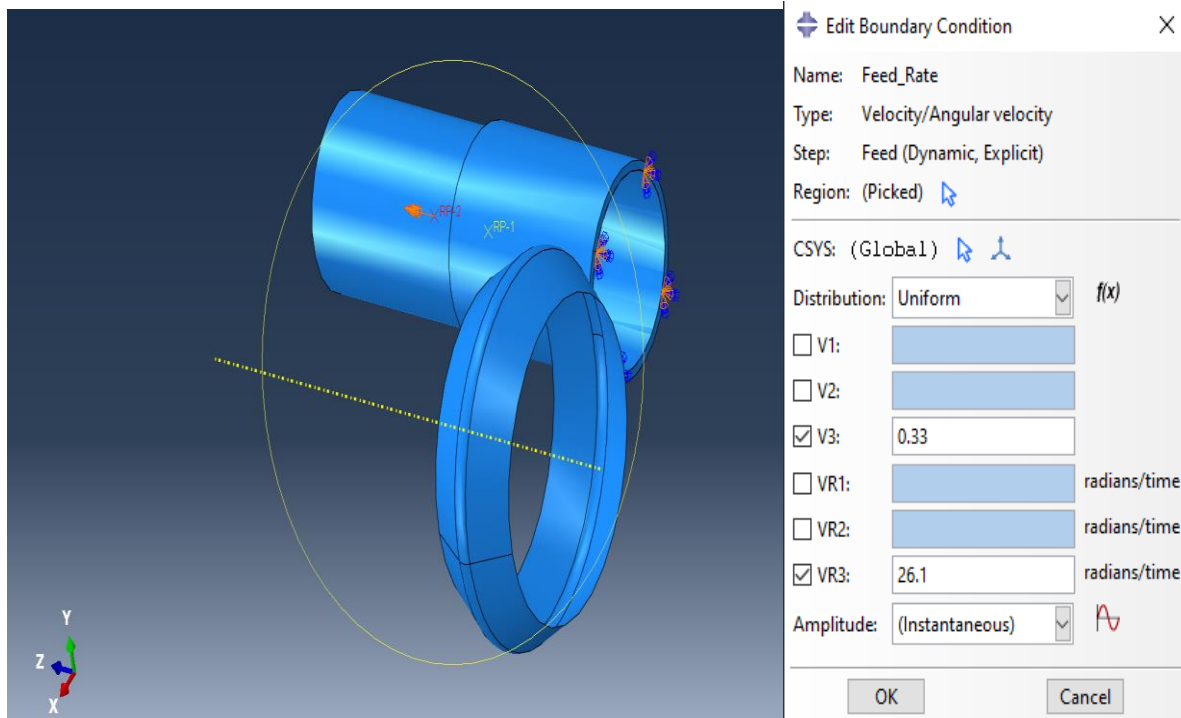

Figure 19 Velocity and Angular velocity incorporated into the Model

As the initial feed and mandrel speed were given in the experiment, they were converted into the Abaqus units format and hence were incorporated into the model.

So initially the feed was in mm/rev while the mandrel speed was in rev/min. That were converted respectively into mm/sec and rad/sec

Parameter	Experiment	Simulation
Feed	0.04mm/rev	0.17 mm/sec
Feed	0.08 mm/rev	0.33 mm/sec
Mandrel Speed	250 rev/min	26.1 rad/sec
Mandrel Speed	420 rev/min	43.9 rad/sec

Table 6 Parameters incorporated in Abaqus

4.1.7 Mesh

The model treated the preform as an elastic-plastic material while treating the rollers as rigid entities. The discretization of the preform results in 4160, eight node linear brick elements, with reduced integration, and hourglass control (C3D8R). The benefits of both Lagrangian and Eulerian approaches were combined using arbitrary Lagrangian-Eulerian (ALE) adaptive meshing. High-quality mesh is maintained because it can move independently of the material.

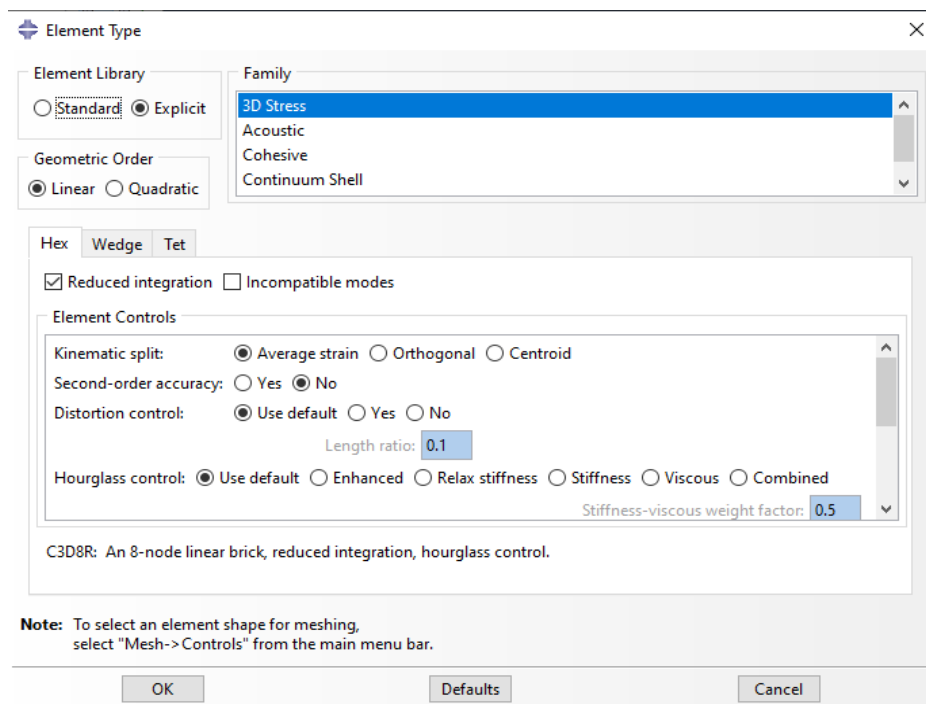

Figure 20 Meshing with C3D8R elements

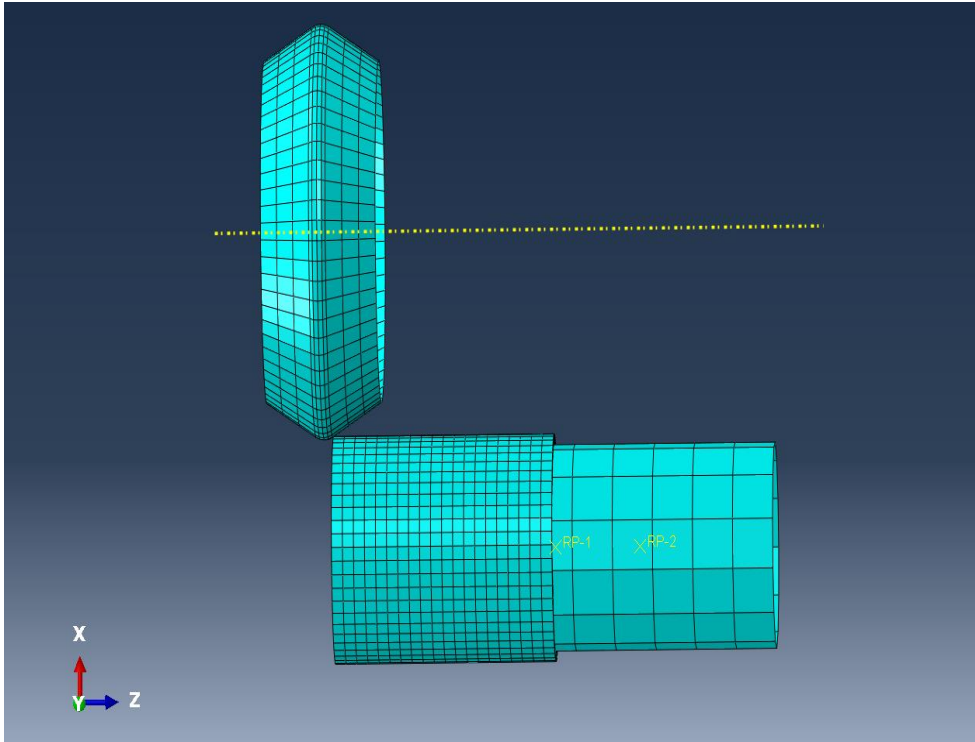

Figure 21 Meshing of Flow forming model

4.1.8 Mesh Convergence

In Abaqus meshing is a very critical factor. Meshing divides the part into the small elements. And these elements further study the impact of forces acting on them and give the solution. It is very important to calculate the appropriate number of elements. i.e., the mesh size that will be used to calculate the result. So, for this purpose the mesh converge is always preferred to decide the appropriate mesh size. Based on that the mesh convergence was established for the model in order to further pursue with the final calculations.

Mesh convergence is done in such a way that one output parameters is selected and the various simulations are performed by changing the element size. So, for present research the Von misses were selected and effects of changing mesh size were observed and value was recorded at specific step time. Based on literature it was found that keeping the fine mesh gives the accurate results. So, from 6mm to 2mm various mesh sizes were selected and simulations were performed.

Finally, it was observed that the difference of Von misses at 2.5mm and 2mm were much less and the value will not converge more. So, the element size of 2mm of preform was opted for this research.

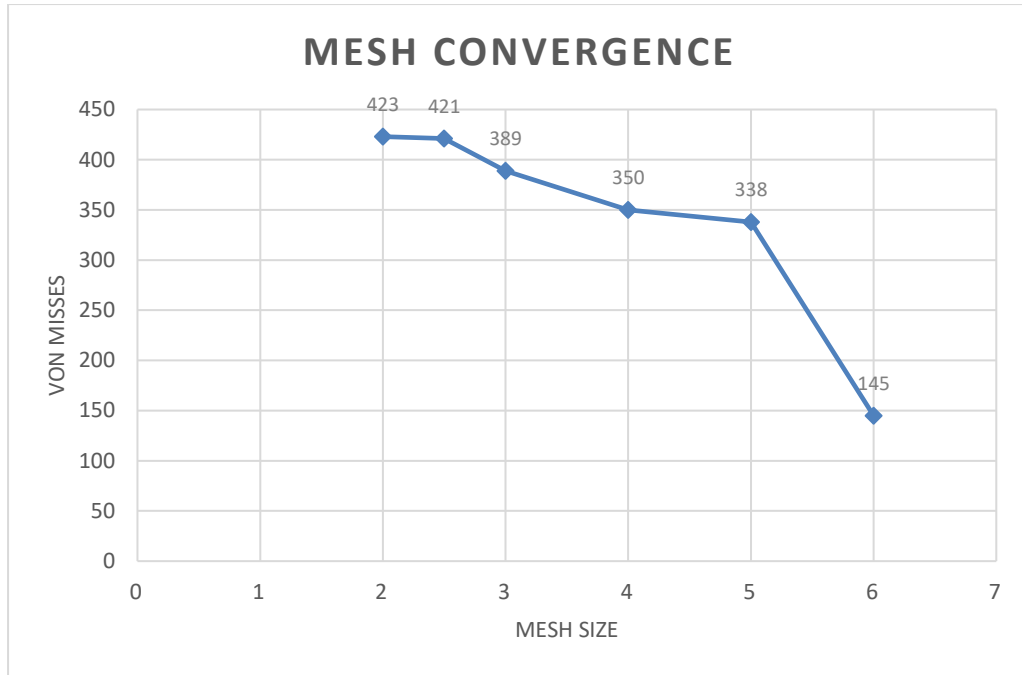

Figure 22 Mesh Convergence Graph

The difference between the von misses at 2mm and 2.5 mm was only **0.4%** which shows that the results is in stable state. Therefore, 2mm mesh size was opted for this research.

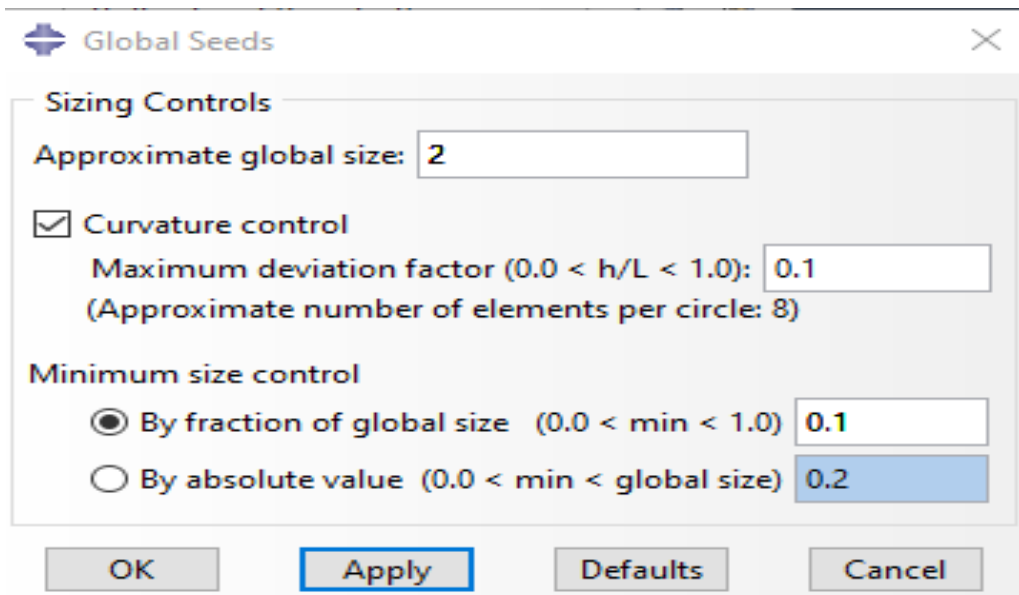

Figure 23 Mesh Size of 2mm Incorporated in Abaqus Model

4.1.9 Validating the Mesh Convergence Model

Once the mesh convergence is accomplished, the model is further observed to verify that it follows the quasi-static response as suggested it [12]. As the dynamic explicit is selected to perform the flow forming analysis therefore it is necessary that the total kinetic energy of the process should be less than 5-10% of the total internal energy. So, for this purpose the history output of the Abaqus was selected with all energies measurements so that the phenomena can be studied.

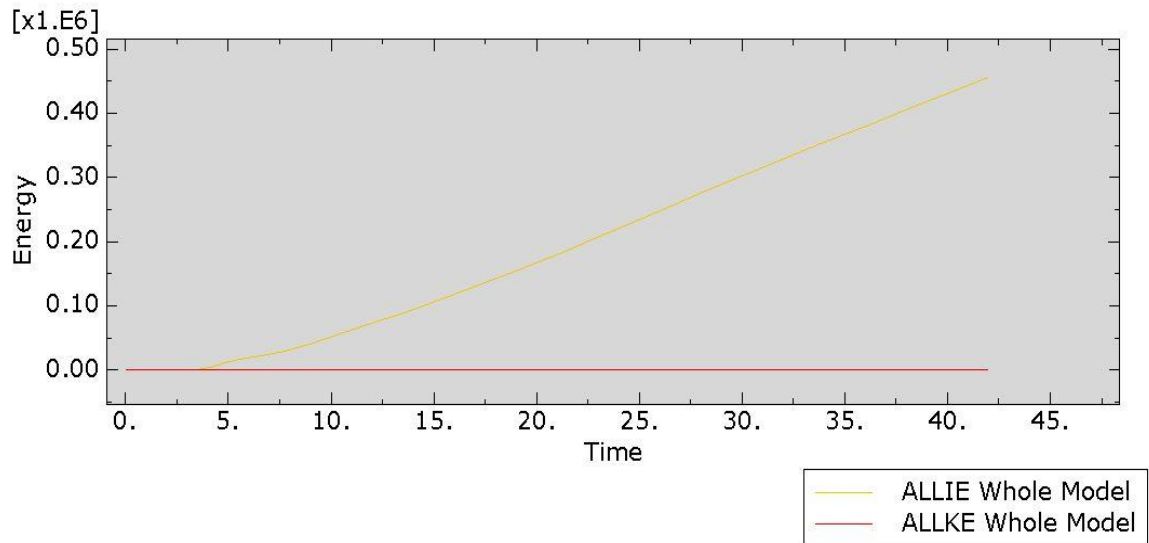

Figure 24 Graph between Internal Energy and Kinetic Energy

Graph shows that the kinetic energy is much less or negligible as compared to the Internal energy. So, the process follows the quasi-static response. And the mass scaling factor of 200 can be used further to carry out the simulations.

4.1.10 Model Validation

The model validation is done based on the research [5]. Model was made and parameters were inserted into the Abaqus. The Von misses and the Stresses were compared with the results of the developed model. The results were in good agreement with the simulation results performed in the research

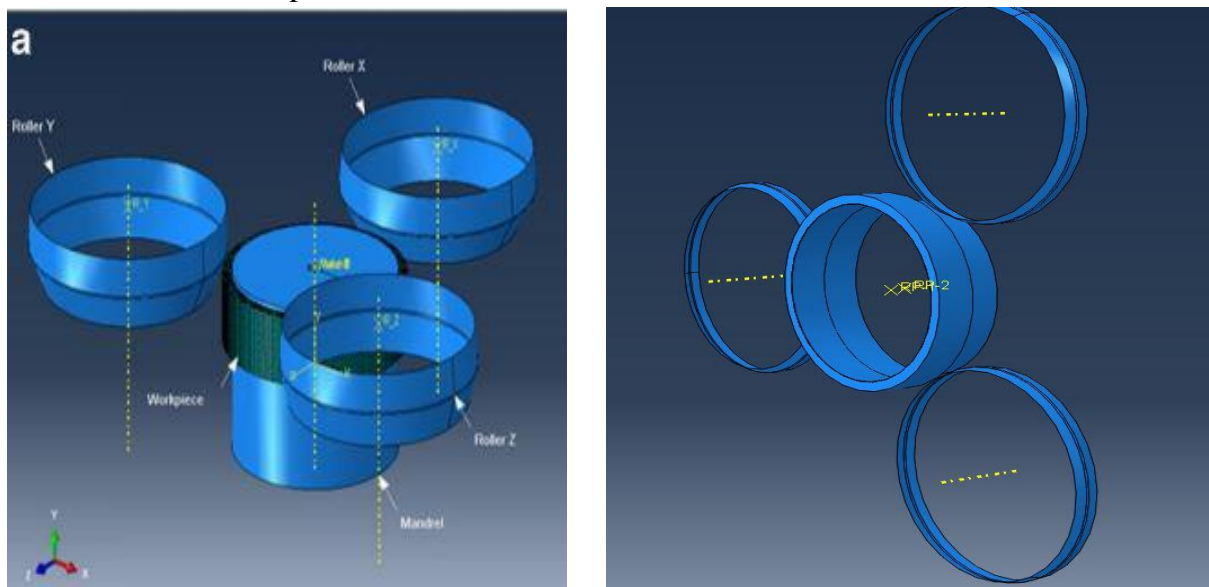

Figure 25 a) Actual Model b) Model developed for Validation

a. Von misses

According to the model, the Von misses achieved were 1082 MPA while the Von misses achieved

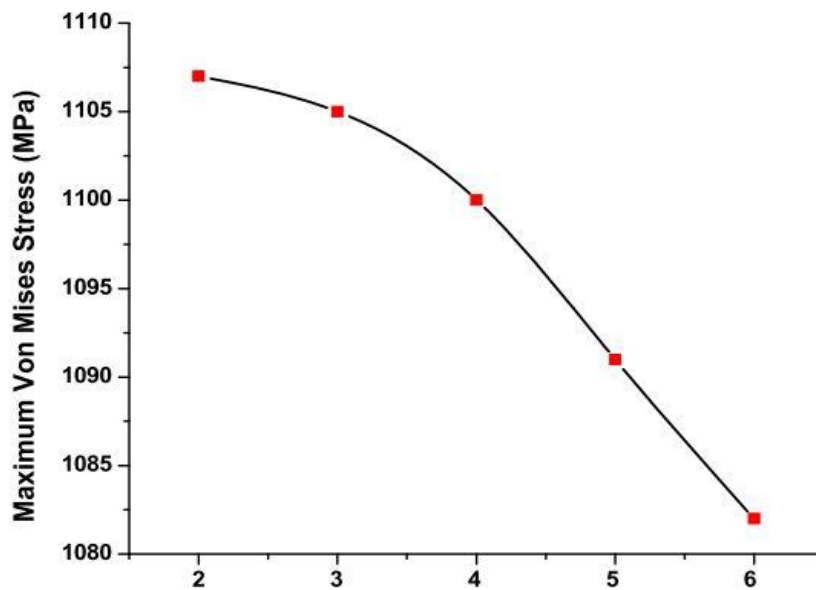

Figure 26 Max Von mises graph [6]

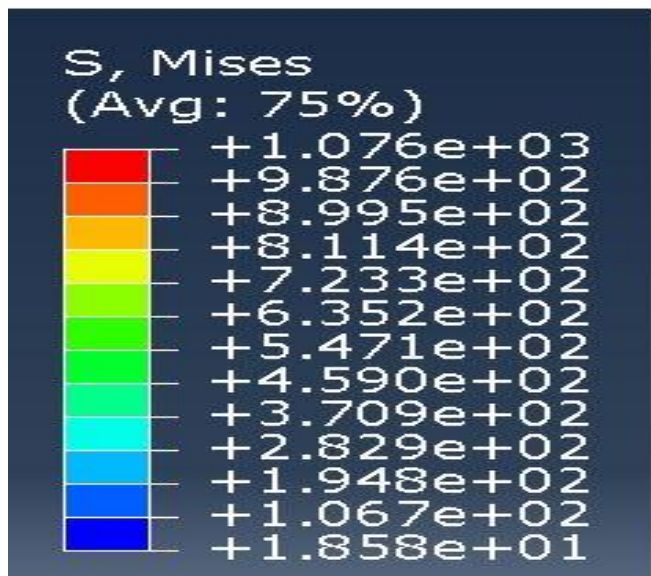

Figure 27 Max Von misses achieved for Validation

Von misses achieved for validation at 6mm mesh size were 1076 Mpa. The difference between the fea conducted by [6] and fea for validation was just **0.5%**

b. Circumferential Stress

The other parameter that was compared is the circumferential stress. It was found that the circumferential stress in the validation research [5] was 1027 Mpa while the circumferential stress obtained through fea was 1038 Mpa. The difference in error was just 1%

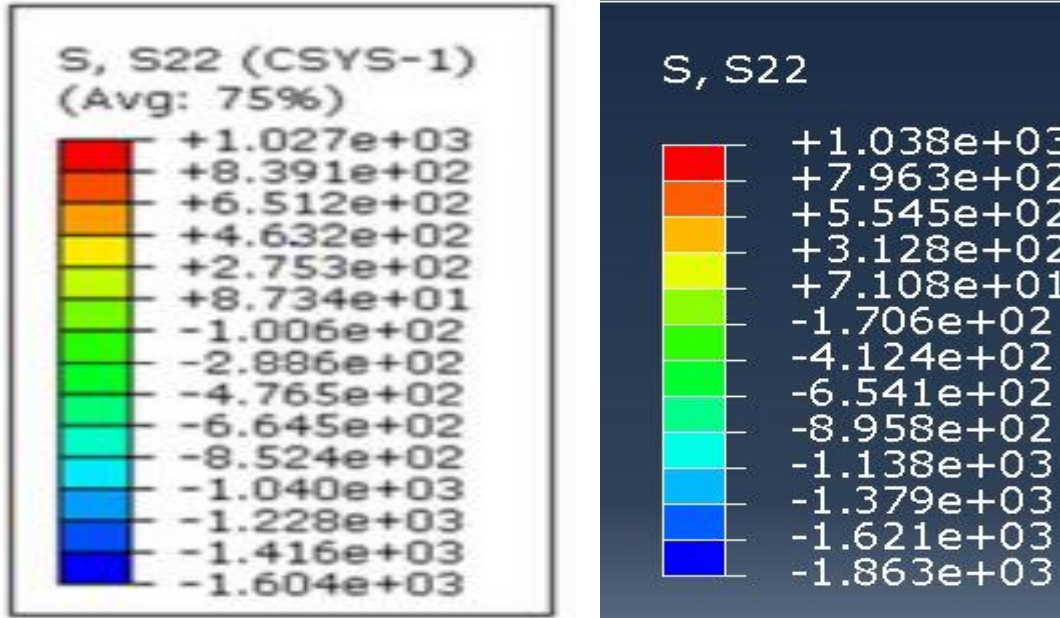

Figure 28 Circumferential Stress for both the models

CHAPTER 5: SIMULATIONS RESULTS AND CONCLUSION

5.1 Results

FEA Analysis was performed for the flow forming model developed in ABAQUS. As per the design of experiments, the simulations were performed by changing the feed rates and mandrel speed. The output parameters were calculated after the simulation was performed. The flow forming forces were therefore calculated using the Abaqus field output requests and trends were then compared with the experimental data. The Von misses and forming forces results for all simulations has been attached below.

5.1.1 Simulation 1

Simulation was performed with feed rate 0.08 mm and mandrel speed 250 rpms.

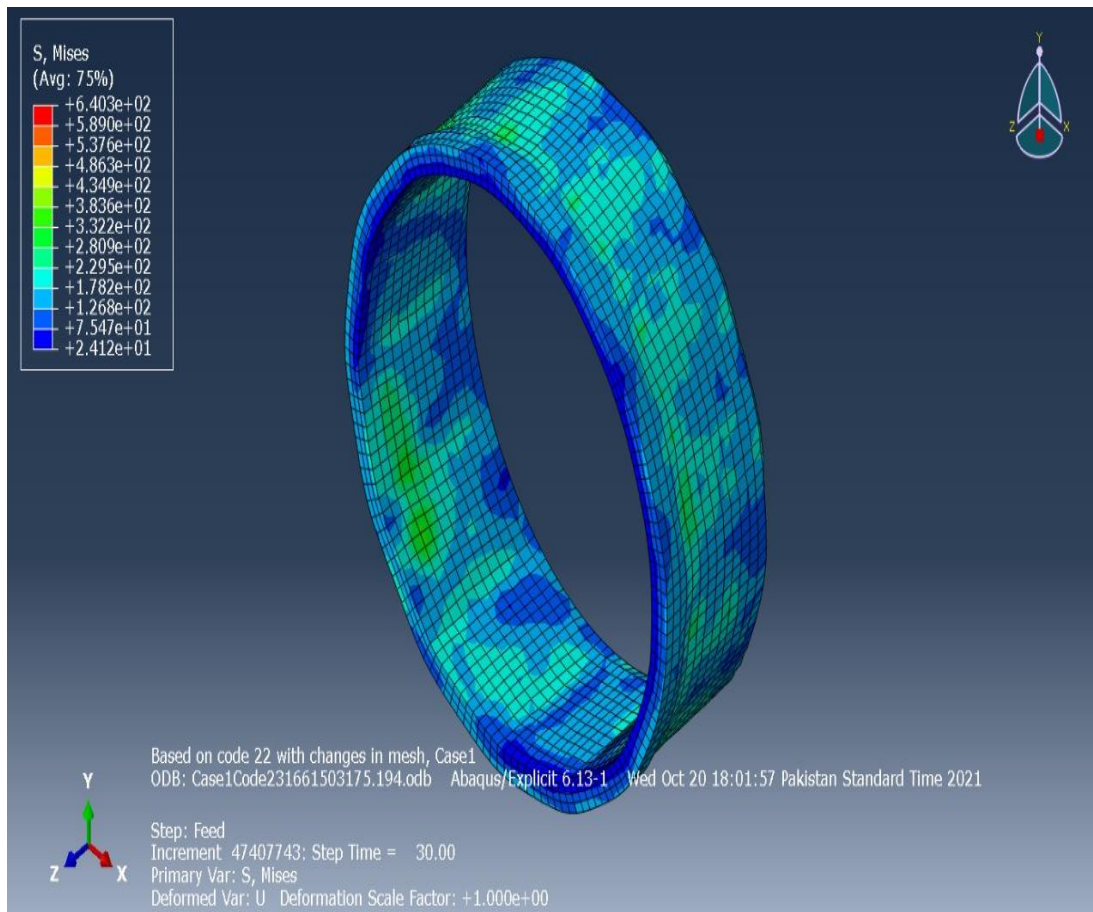

Figure 29 Von Mises occurring in Preform Case 1

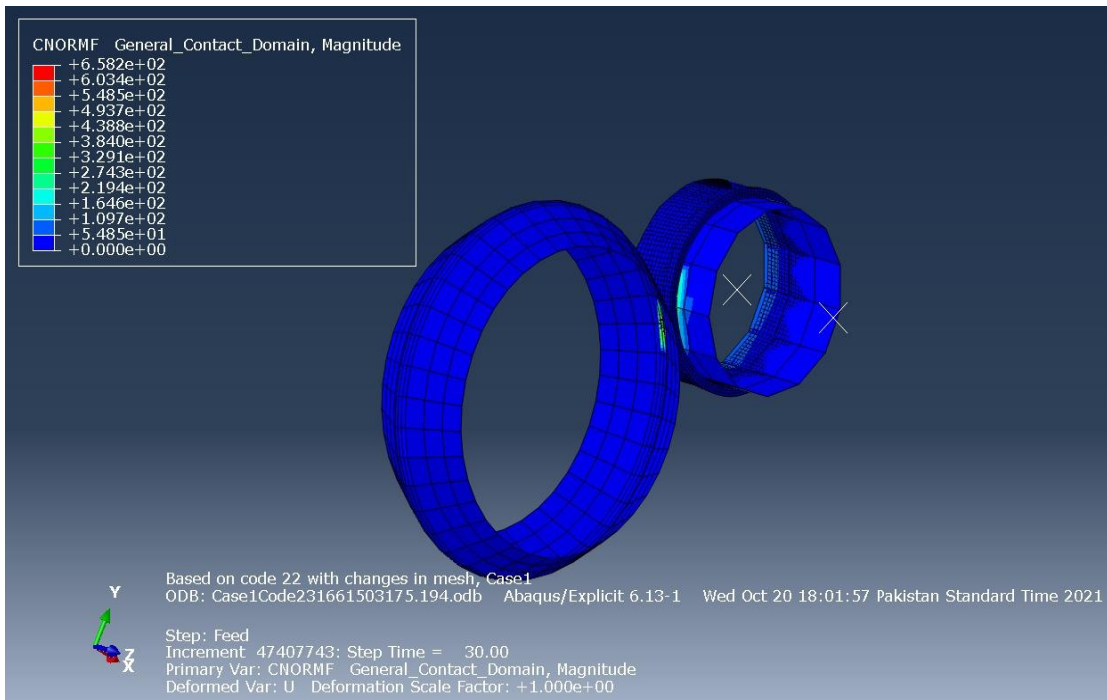

Figure 30 Magnitude of Normal Force in Case 1

5.1.1.1 Forming Forces

Forming forces were obtained as the output parameter is the simulation. The axial, radial and circumferential forces were calculated and compared with the experimental data.

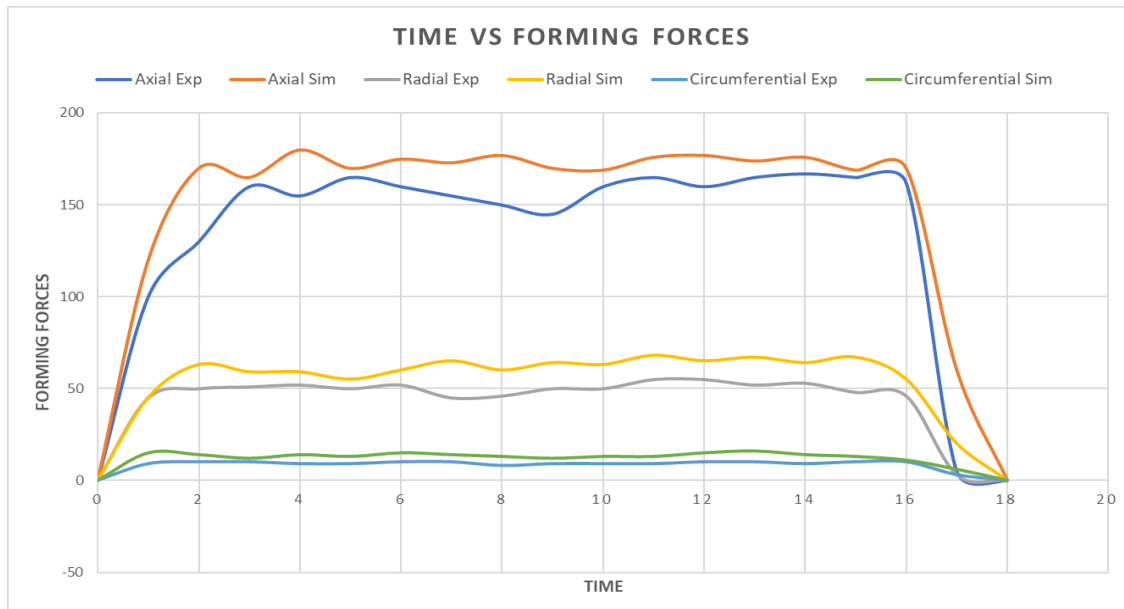

Table 7 Graph in-between Time and Forming Forces (Case1)

5.1.2 Simulation 2

Simulation was performed with feed rate 0.08 mm and mandrel speed 420 rpms.

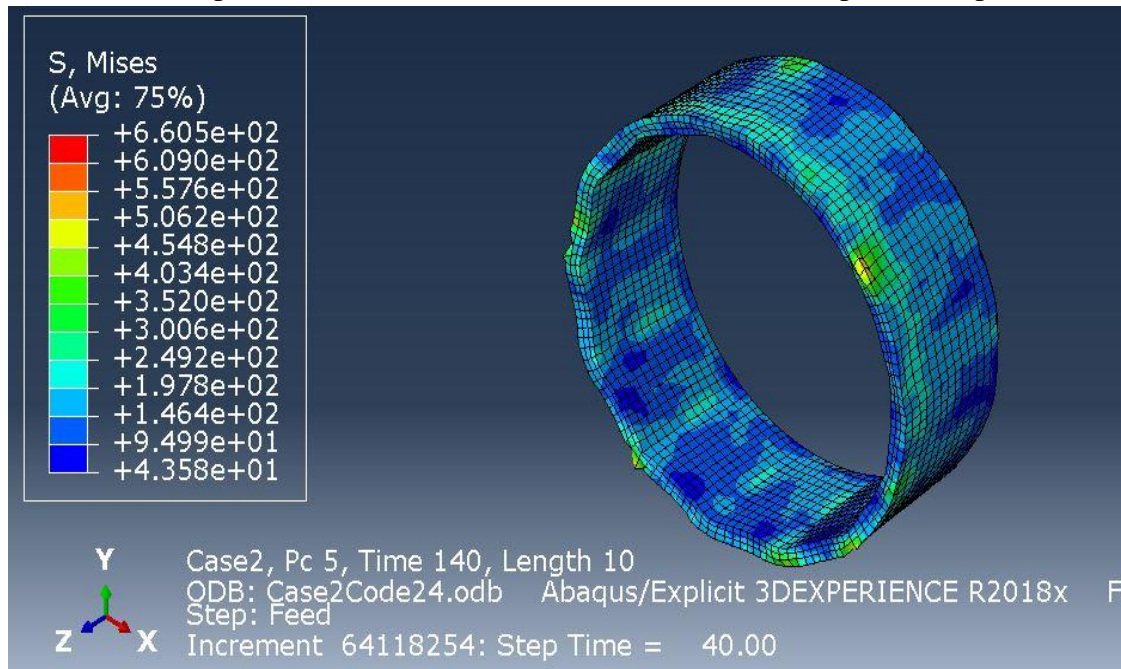

Figure 31 Von Mises occurring in Preform Case 2

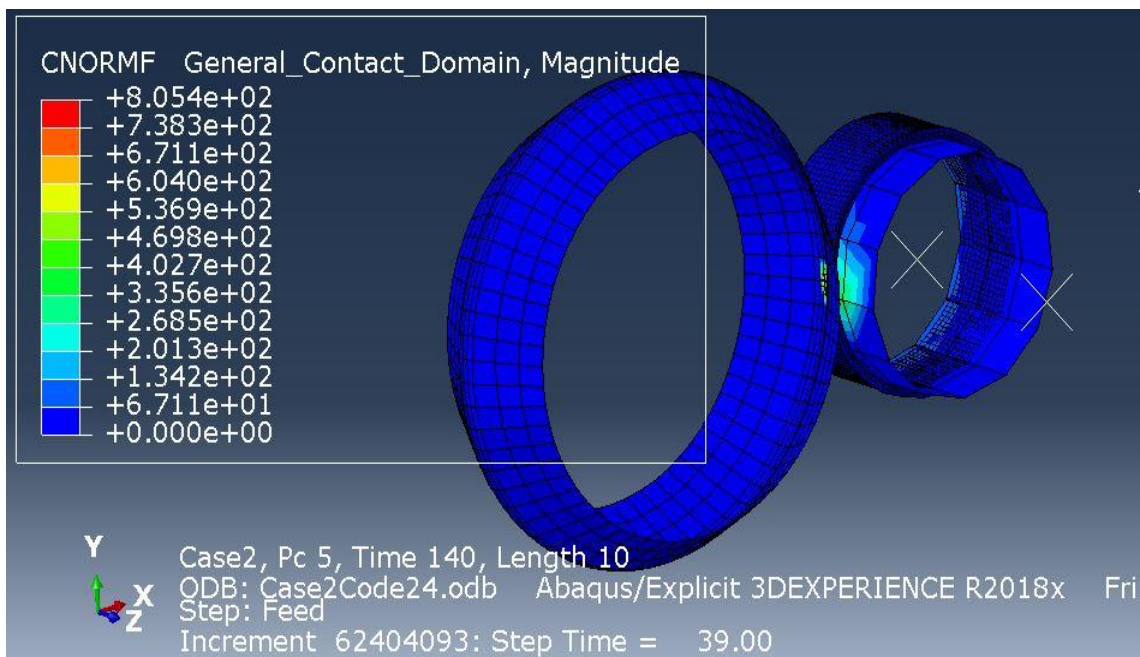

Figure 32 Magnitude of Normal Force in Case 2

5.1.2.1 Forming Forces

Forming forces were obtained as the output parameter is the simulation. The axial, radial and circumferential forces were calculated and compared with the experimental data.

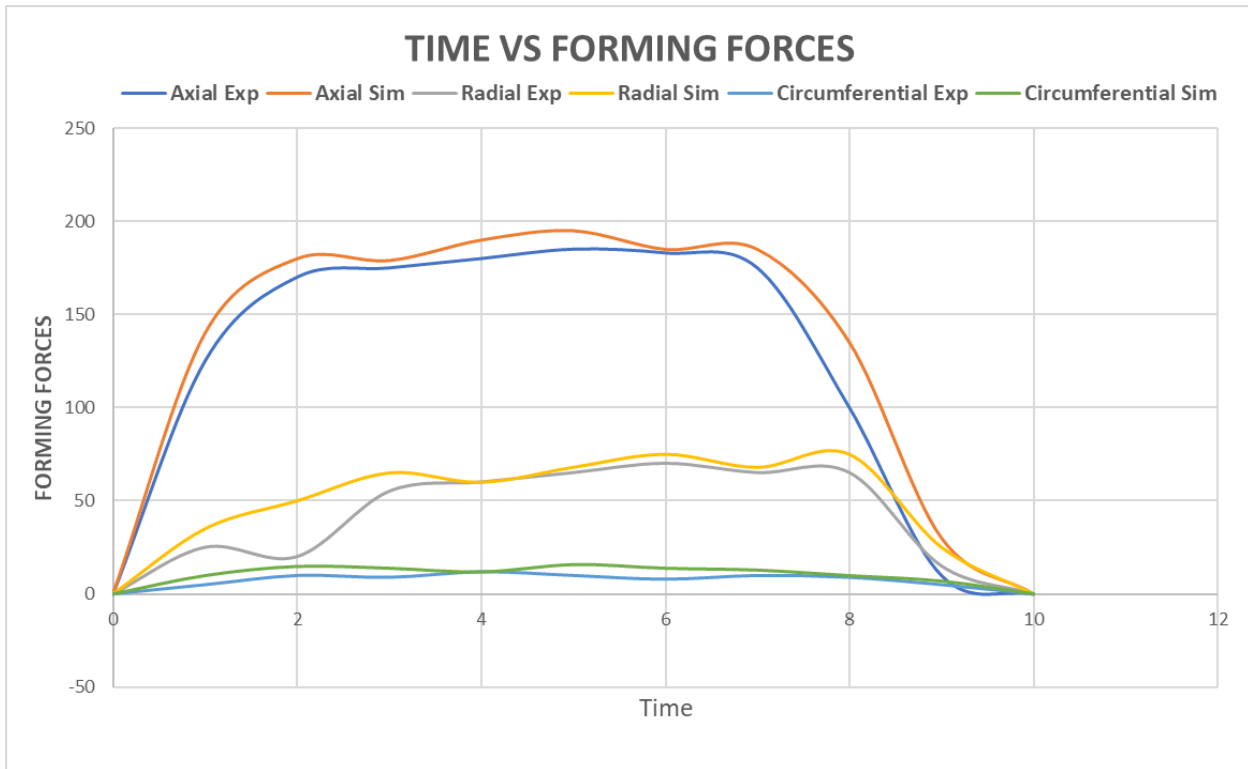

Table 8 Graph in-between Time and Forming Forces (Case2)

5.1.3 Simulation 3

Simulation was performed with feed rate 0.04 mm and mandrel speed 250 rpms.

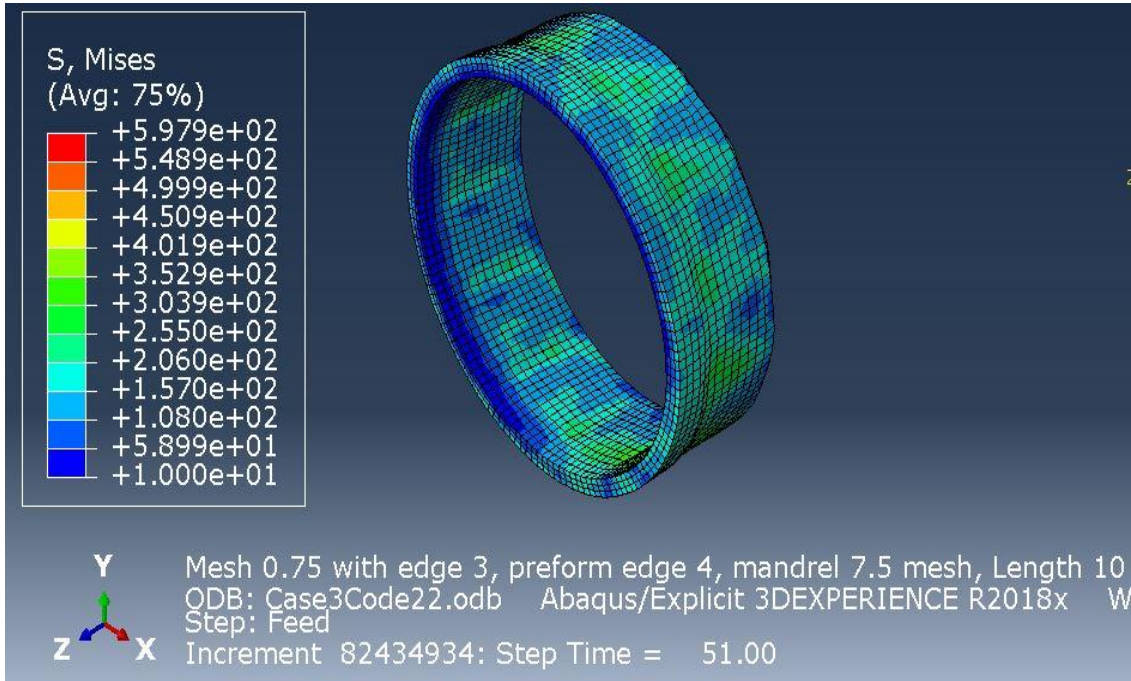

Figure 33 Von Mises occurring in Preform Case 3

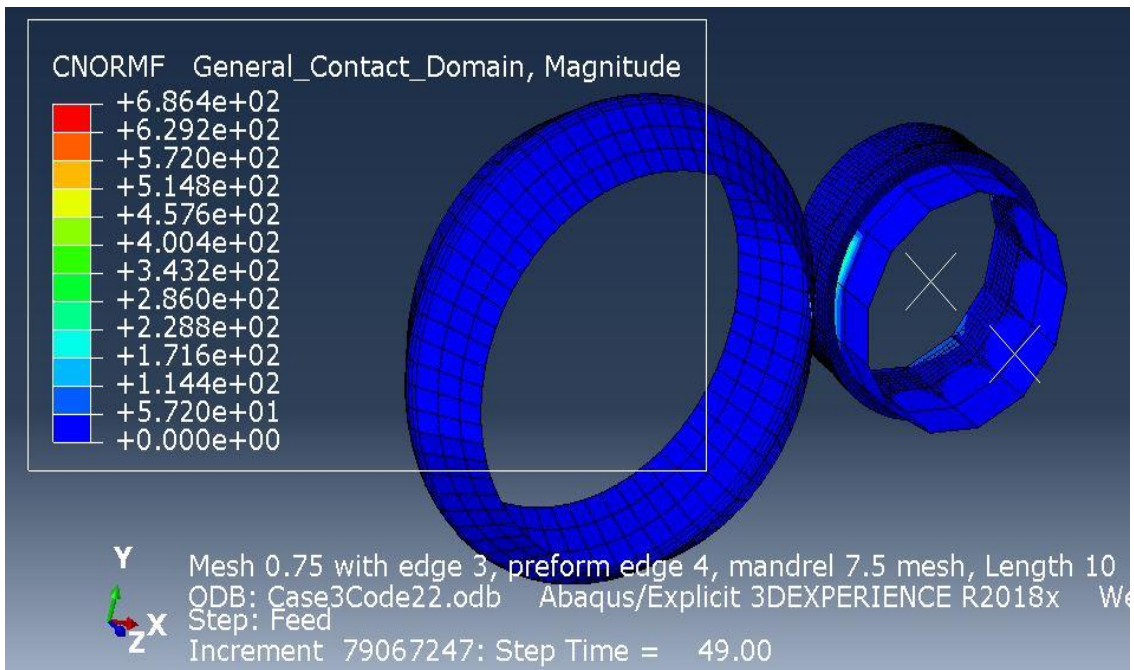

Figure 34 Magnitude of Normal Force in Case 3

5.1.3.1 Forming Forces

Forming forces were obtained as the output parameter in the simulation. The axial, radial and circumferential forces were calculated and compared with the experimental data.

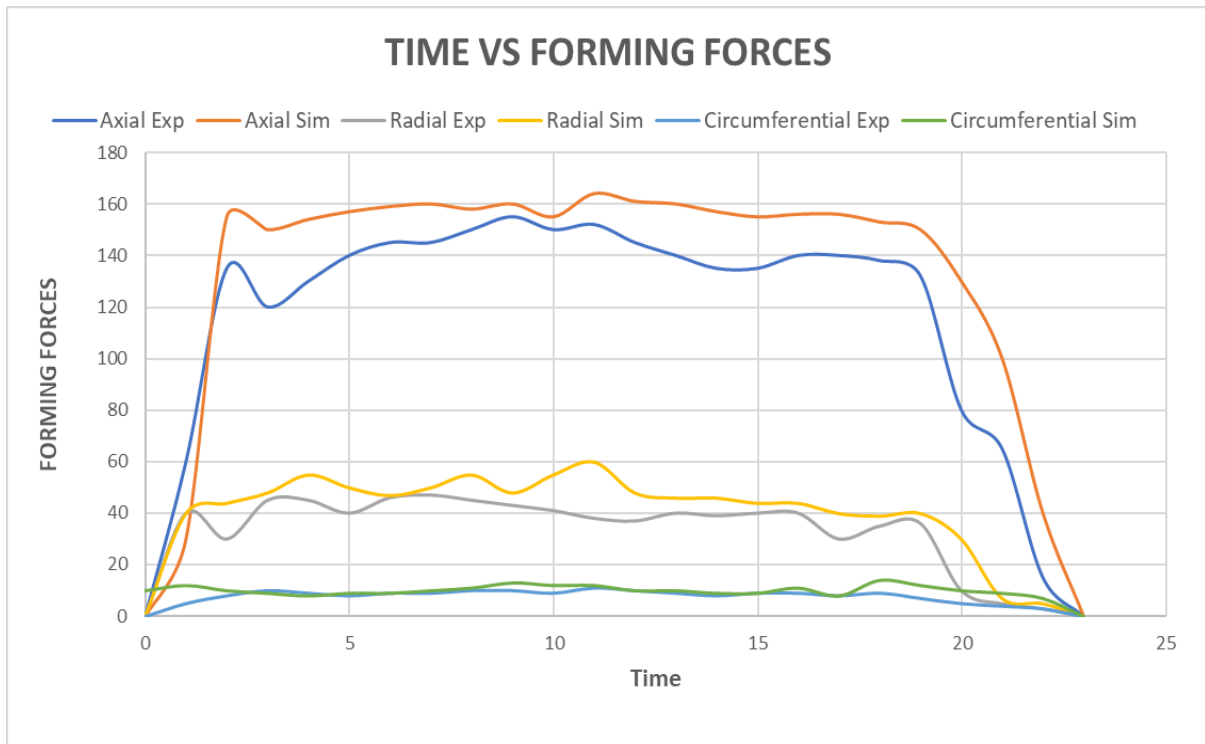

Table 9 Graph in-between Time and Forming Forces (Case3)

5.1.4 Simulation 4

Simulation was performed with feed rate 0.04 mm and mandrel speed 420 rpms.

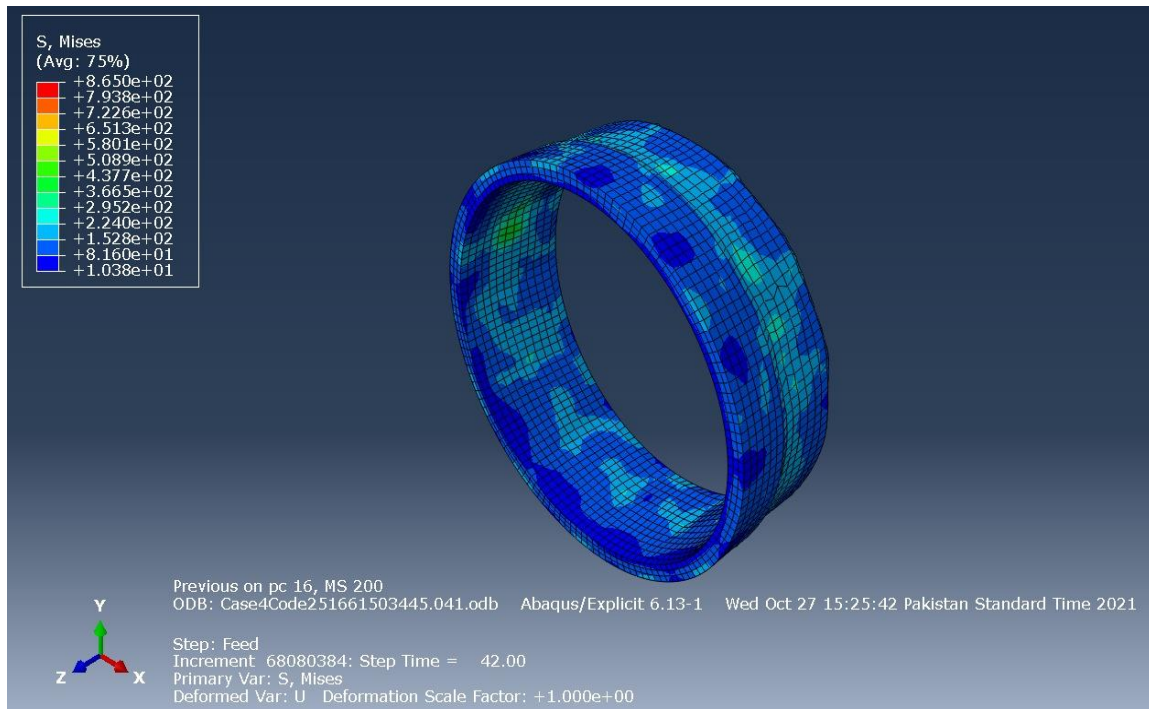

Figure 35 Von Mises occurring in Preform Case 4

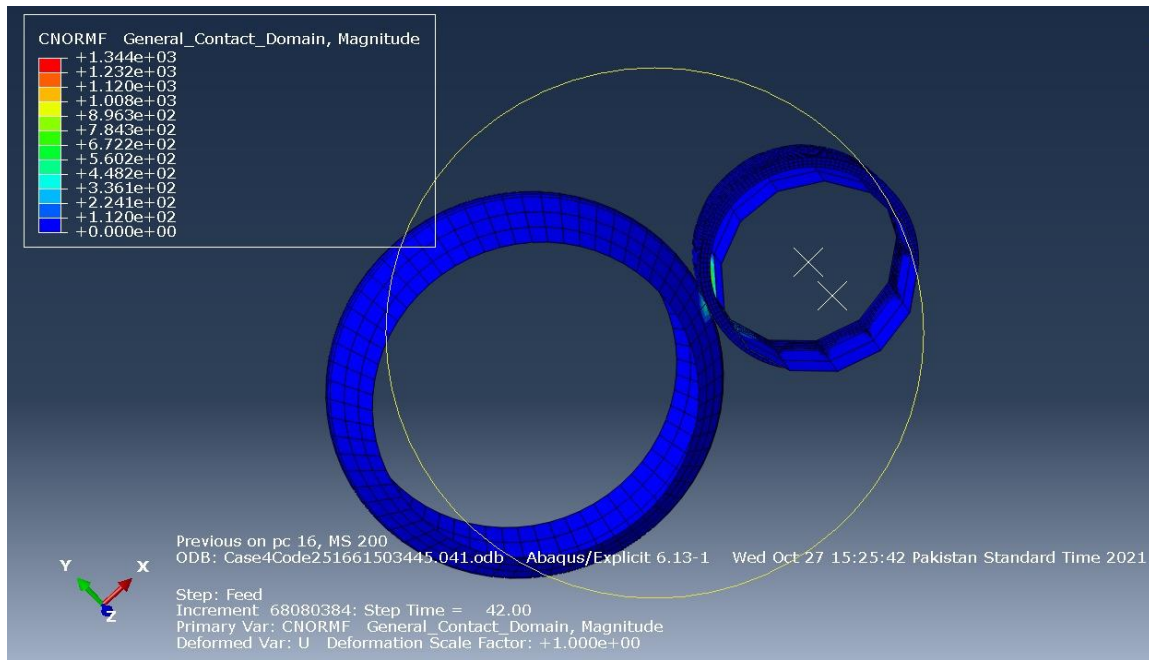

Figure 36 Magnitude of Normal Force in Case 4

5.1.4.1 Forming Forces

Forming forces were obtained as the output parameter is the simulation. The axial, radial and circumferential forces were calculated and compared with the experimental data.

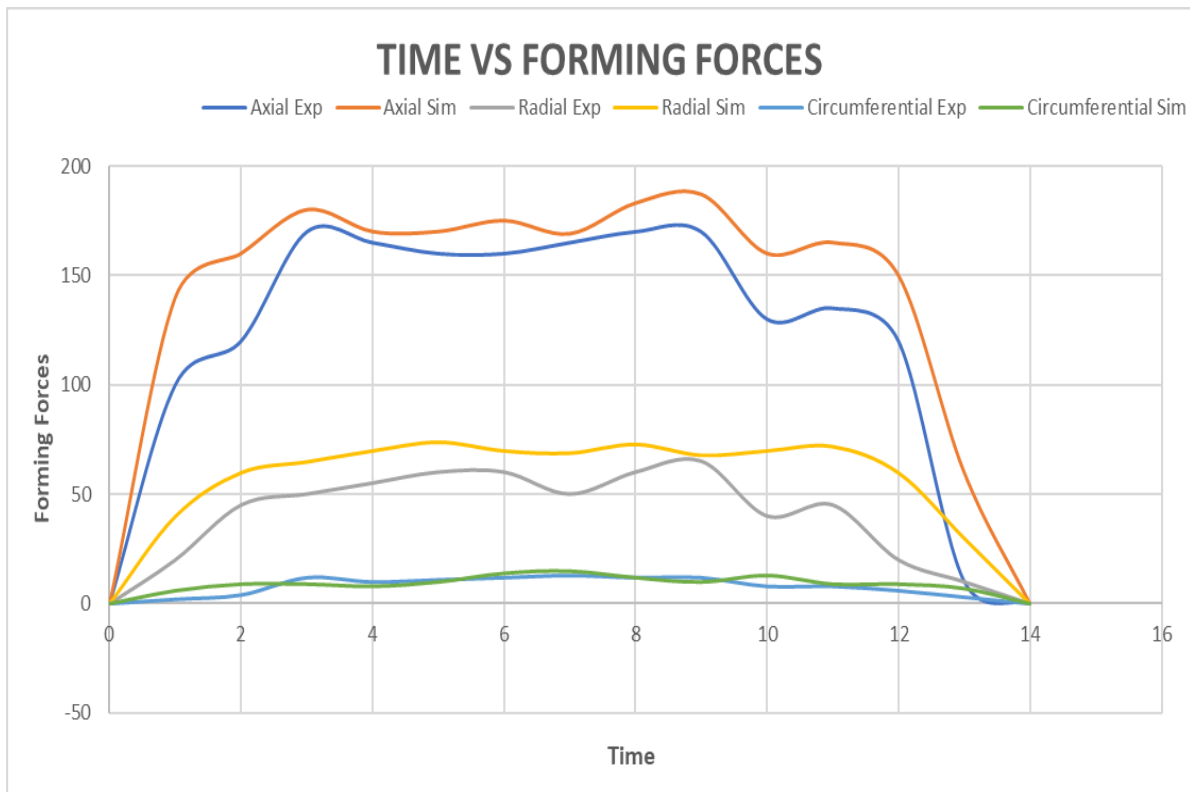

Table 10 Graph in-between Time and Forming Forces (Case4)

5.2 Comparison with Experimental

No of Simulation (Feed, Rpm)	Max Axial Force (Simulation)	Max Axial Force (Experimental)	Difference in Error
Simulation 1 (0.08,250)	180	165	7.8%
Simulation 2 (0.08,420)	195	186	4.6%
Simulation 3 (0.04,250)	164	159	3.0%
Simulation 4 (0.04,420)	187	170	9.0%

Table 11 Comparison with Experimental

5.3 Conclusion

FEA Model for the flow forming of AL 7075 alloy was developed using the Abaqus software. Forward flow forming was employed in the model. In order to reduce the computational time and cost, explicit dynamic methodology was applied. Boundary conditions of roller feed and its rotation was incorporated to the developed model and the preform was encastered from its edge to the mandrel. Based on the experimental study the simulation was carried out by changing feed rate (0.04mm,0.08mm) and mandrel speed (250rpm,420rpm). The model developed was benchmarked for von misses and circumferential force. The results were in accordance with the benchmarked results and hence the model was validated. As per the output parameters, the forming forces were calculated. i.e., Axial force, radial force, and circumferential force. The results were compared with the experimental results. It was observed that the Axial force was higher in all the simulations, followed by the radial force and the circumferential force was the least among all. The axial force is higher particularly due to the stretching of the material. Also, the increase in the axial force was more significant when the rpm was increased from 250 to 420 rpm. The maximum axial force of 195Mpa was observed when the rpm was 420 rpm and feed was 0.08mm. The difference in the experimental and simulation was very less. The present result also showed the von misses occurred in each simulation.

5.4 Future Work

In future, this model can be used to study out the other operational parameters like depth of cut, reduction ratio, radius of roller. These parameters will further help in selecting the appropriate forming conditions so that better flow formed can be obtained. Further the model can be used for other materials to simulate the effect of flow forming on them. Different output results can be studied using this model created in ABAQUS for better understanding defects and then optimizing them to achieve high precise and good finishing flow formed parts.

References

- [1] D. Marini, D. Cunningham, and J. Corney, "A review of flow forming processes and mechanisms," *Key Eng. Mater.*, vol. 651–653, pp. 750–758, 2015, doi: 10.4028/www.scientific.net/KEM.651-653.750.
- [2] R. J. Bhatt and H. K. Raval, "Comparative Study of Forward and Backward Flow Forming Process using Finite Element Analysis," *Bonfring Int. J. Ind. Eng. Manag. Sci.*, vol. 5, no. 2, pp. 46–50, 2015, doi: 10.9756/bijiems.8053.
- [3] R. J. Bhatt and H. K. Raval, "Semi empirical modeling of flow forming process," *Int. J. Mod. Manuf. Technol.*, vol. 9, no. 1, pp. 13–19, 2017.
- [4] R. J. Bhatt and H. K. Raval, "Influence of Operating Variables during Flow Forming Process," *Procedia CIRP*, vol. 55, pp. 146–151, 2016, doi: 10.1016/j.procir.2016.08.025.
- [5] H. Shinde, P. Mahajan, A. K. Singh, R. Singh, and K. Narasimhan, "Process modeling and optimization of the staggered backward flow forming process of maraging steel via finite element simulations," *Int. J. Adv. Manuf. Technol.*, vol. 87, no. 5–8, pp. 1851–1864, 2016, doi: 10.1007/s00170-016-8559-7.
- [6] N. Kim, H. Kim, and K. Jin, "Minimizing the axial force and the material build-up in the tube flow forming process," *Int. J. Precis. Eng. Manuf.*, vol. 14, no. 2, pp. 259–266, 2013, doi: 10.1007/s12541-013-0036-8.
- [7] N. A. Razani, A. Jalali Aghchai, and B. Mollaei Dariani, "Experimental study on flow forming process of AISI 321 steel tube using the Taguchi method," *Proc. Inst. Mech. Eng. Part B J. Eng. Manuf.*, vol. 225, no. 11, pp. 2024–2031, 2011, doi: 10.1177/0954405411398195.
- [8] M. Srinivasulu, M. Komaraiah, and C. S. K. P. Rao, "Experimental studies on the characteristics of AA6082 flow formed tubes," *J. Mech. Eng. Res.*, vol. 4, no. 6, pp. 192–198, 2012, doi: 10.5897/JMER11.063.
- [9] S. Kumar, "Experimental Investigation of Flow Experimental Investigation of Flow," vol. 247667, no. 3, pp. 1740–1743, 2011.

- [10] R. J. Bhatt and H. K. Raval, "An investigation of forces during flow forming process," *Int. J. Mod. Manuf. Technol.*, vol. 8, no. 1, pp. 12–17, 2016.
- [11] A. K. Srivastwa, P. K. Singh, and S. Kumar, "Experimental investigation of flow forming forces in Al7075 and Al2014 - A comparative study," *Mater. Today Proc.*, vol. 47, no. xxxx, pp. 2715–2719, 2021, doi: 10.1016/j.matpr.2021.02.781.
- [12] C. C. Wong, "Incremental forming of solid cylindrical components using flow forming principles," *J. Mater. Process. Technol.*, vol. 153–154, no. 1–3, pp. 60–66, 2004, doi: 10.1016/j.jmatprotec.2004.04.102.
- [13] G. OZER and A. KARAASLAN, "Properties of AA7075 aluminum alloy in aging and retrogression and reaging process," *Trans. Nonferrous Met. Soc. China (English Ed.)*, vol. 27, no. 11, pp. 2357–2362, 2017, doi: 10.1016/S1003-6326(17)60261-9.
- [14] N. S. Brar, V. S. Joshi, and B. W. Harris, "Constitutive model constants for Al7075-T651 and Al7075-T6," *AIP Conf. Proc.*, vol. 1195, no. 1, pp. 945–948, 2009, doi: 10.1063/1.3295300.
- [15] S. Jayabal, "CHARACTERIZATION OF PARTICULATE- REINFORCED ALUMINIUM 7075 / TIB2 COMPOSITES," no. October, 2017.
- [16] N. Metal and A. Alloy, "Aluminum 7075-O," pp. 21–23.
- [17] S. Rasae, A. H. Mirzaei, and D. Almasi, "Constitutive modelling of Al7075 using the Johnson–Cook model," *Bull. Mater. Sci.*, vol. 43, no. 1, 2020, doi: 10.1007/s12034-019-1987-x.