

Brought to You by

The logo for Team LiB features the text "Team LiB" in a bold, yellow, sans-serif font with a black outline. The text is centered within a blue, horizontal, teardrop-shaped swoosh that curves upwards at both ends.

Team LiB

Like the book? Buy it!

The cover features a complex abstract design of white lines on a background split diagonally from the top-left to the bottom-right. The upper-left portion is black, and the lower-right portion is orange. The white lines form a dense, overlapping pattern of circles and straight lines, resembling a technical drawing or a schematic of a microwave component. Two rectangular shapes with internal cross-like structures are visible within the line pattern, one on the left and one on the right.

HARRI ESKELINEN • PEKKA ESKELINEN

MICROWAVE COMPONENT MECHANICS



CD-ROM INCLUDED

Microwave Component Mechanics

DISCLAIMER OF WARRANTY

The technical descriptions, procedures, and computer programs in this book have been developed with the greatest of care and they have been useful to the author in a broad range of applications; however, they are provided as is, without warranty of any kind. Artech House, Inc. and the author and editors of the book titled *Microwave Component Mechanics* make no warranties, expressed or implied, that the equations, programs, and procedures in this book or its associated software are free of error, or are consistent with any particular standard of merchantability, or will meet your requirements for any particular application. They should not be relied upon for solving a problem whose incorrect solution could result in injury to a person or loss of property. Any use of the programs or procedures in such a manner is at the user's own risk. The editors, author, and publisher disclaim all liability for direct, incidental, or consequent damages resulting from use of the programs or procedures in this book or the associated software.

For a listing of recent titles in the *Artech House Microwave Library*,
turn to the back of this book.

Microwave Component Mechanics

Harri Eskelinen
Pekka Eskelinen



Artech House
Boston • London
www.artechhouse.com

Library of Congress Cataloging-in-Publication Data

Eskelinen, Harri.

Microwave component mechanics/Harri Eskelinen, Pekka Eskelinen.

p. cm. — (Artech House microwave library)

Includes bibliographical references and index.

ISBN 1-58053-368-X (alk. paper)

1. Microwave devices—Design and construction. I. Eskelinen, Pekka. II. Title.
III. Series.

TK7876.E85 2003

621.381'33—dc21

2002043667

British Library Cataloguing in Publication Data

Eskelinen, Harri

Microwave component mechanics.—(Artech House microwave library)

1. Microwave devices—Design and construction

I. Title II. Eskelinen, Pekka

621.3'8133

ISBN 1-58053-368-X

Cover design by Igor Valdman

© 2003 ARTECH HOUSE, INC.

685 Canton Street

Norwood, MA 02062

All rights reserved. Printed and bound in the United States of America. No part of this book may be reproduced or utilized in any form or by any means, electronic or mechanical, including photocopying, recording, or by any information storage and retrieval system, without permission in writing from the publisher.

All terms mentioned in this book that are known to be trademarks or service marks have been appropriately capitalized. Artech House cannot attest to the accuracy of this information. Use of a term in this book should not be regarded as affecting the validity of any trademark or service mark.

International Standard Book Number: 1-58053-368-X

Library of Congress Catalog Card Number: 2002043667

10 9 8 7 6 5 4 3 2 1

Contents

	Acknowledgments	<i>xv</i>
	Introduction	<i>xvii</i>
	Part 1: Design for Manufacturability and Assembly of Mechanical Microwave Components	1
1	Special Requirements for Microwave Mechanics	3
1.1	Fundamentals of Microwaves	4
1.1.1	Maxwell's Equations	4
1.1.2	General Wave Propagation	5
1.2	Dimensional Uncertainties	8
1.3	Material Problems	15
1.3.1	A Good Conductor	17
1.3.2	Electromagnetic Radiation	19
1.3.3	Electromagnetic Waves Initiated by Cavities	22
1.4	Connection Philosophies	26

1.5	Typical User and Application Profiles	27
	References	27
2	Systematic Flowchart Model	29
2.1	Principles of Systematic Design	29
2.1.1	Some Assisting Tools	31
2.1.2	List of Requirements	33
2.2	Advanced Methodology for Designing Microwave Mechanics	34
2.2.1	Basic Elements of the Advanced Methodology	35
2.2.2	Flowchart Presentation of the Tuned Methodology	39
	References	42
3	Material Selection for Microwave Mechanics	45
3.1	Basic Guidelines for Microwave Designers	45
3.2	Effects of the Product's Operating Frequency	47
3.2.1	Electromagnetic Losses	47
3.2.2	Definition of the Penetration Depth	48
3.3	Effects of the Operating Environment	51
3.4	Metallic Components	54
3.4.1	Oxygen-Free Copper	55
3.4.2	Superconductor Oxygen-Free Copper	55
3.4.3	Beryllium Copper Alloy	56
3.4.4	Phosphorus Bronze	57
3.4.5	Brass	58
3.4.6	Stainless Steels	58
3.4.7	Aluminum Alloys	60
3.4.8	Invar	62
3.5	Use of Plastics	64
3.5.1	PTFE	64
3.5.2	PE	64
3.5.3	Other Fluorine Plastics	65
3.5.4	PEEK	65

3.5.5	Polyphenylene Oxide	66
3.5.6	Reinforced Plastics	66
3.6	Utilization of Ceramic Materials and Powder Metallurgy	66
3.6.1	Powder-Metallurgically Manufactured Materials for Microwave Mechanics	69
3.6.2	Application Areas of Ceramic Materials in Microwave Mechanics	73
3.6.3	Low Temperature Cofired Ceramics	74
	References	77
4	Computer-Aided Environment for Design Work	79
4.1	Integration of Basic CAD Tools	80
4.1.1	Interaction Between Virtual Engineering and Hypermedia Applications in Controlling Heat Input During Welding of Microwave Components	86
4.1.2	Integration of Computer-Assisted Engineering and Microwave Mechanics Simulation in Welded Stripline Filter Design	94
4.2	Typical Simulation Software Solutions for Microwaves	96
4.3	Integration Problems of Current CAD Applications	102
4.3.1	Problems in CAD Applications Made for General Mechanical Engineering	102
4.3.2	Problems in CAD Applications Developed for Microwave Design	103
	References	108
5	Instructions for Technical Documentation and Dimensioning	111
5.1	The Relationship Between RF Parameters and Mechanical Parameters	112
5.2	Differences Between DFMA- and Performance-Oriented Approaches	114

5.3	On the Suitability of General Manufacturing Tolerances for MW Mechanics	116
	References	118
6	<u>Effects of Production Volume and Related Topics</u>	119
6.1	General Aspects Related to the Evaluation of Production Costs	119
6.1.1	Design Costs	119
6.1.2	Material Costs	120
6.1.3	Manufacturing Costs	120
6.1.4	Costs Related to the Expected Lifetime of the Product	120
6.2	Relationship Between Manufacturing Costs and Surface Finish	121
6.3	Relationship Between Manufacturing Costs and Dimensional Tolerance	122
6.4	Design for Manufacturability	122
6.4.1	Goals of DFM/DFMA	123
6.4.2	The Barrier Between Designing and Manufacturing	123
6.4.3	Putting DFM in Practice	125
6.4.4	Additional Tools for DFM	127
6.4.5	More Effective Use of DFM	128
6.5	A Cross-Technological Approach	129
6.6	Concurrent Engineering Design	131
6.6.1	The Design Process for CE	132
6.6.2	Manufacturability for CE Design	133
6.7	Manufacturing Costs of Prototypes	134
6.8	Quality Aspects	135
6.9	Cost Evaluation by Utilizing Parametric Component Design	135
6.10	Cost Accumulation in Laser Processed Components	136
6.11	Manufacturing Costs of Other Manufacturing Processes	141

6.12	A Multilevel Optimizing Approach for Cost-Effective Production	141
	References	148
Part 2: Manufacturing Technologies for Some Passive Microwave Components		151
7	Welded Components	153
7.1	Welding Processes for the Topic Area	153
7.2	Laser Welding in General	154
7.2.1	Parameters of Laser Welding	156
7.3	Laser-Welded Stripline Filter	157
7.4	Utilizing Ultrasonic Welding in Filter Constructions	164
7.5	Welded Joint Geometries of Microwave Cavity Resonators and Waveguides	170
7.5.1	Practical Welding Instructions for Cavity Resonators and Waveguides	174
7.6	Welded Radiating Elements of Patch Antennas	177
7.7	A Comparison of Welding Processes for Encapsulating Electronics	192
7.7.1	Advantages of Laser Welded Sealing	193
7.7.2	Projection Welding Application	197
	References	200
8	Other Joining Technologies	203
8.1	Assembly Rules for Screw Joints to Obtain Reliability and Required Microwave Performance	203
8.2	Glued Joints	205
8.2.1	Acrylic-Based Adhesives	205
8.2.2	Cyanoacrylate-Based Adhesives	206
8.2.3	UV-Cured Adhesives	206
8.2.4	Adhesives with Good Electrical Conductivity	206

8.2.5	Adhesives for High-Strength Applications	208
8.2.6	High-Temperature Ceramic Adhesives	209
8.3	Applications of Fits	209
	References	210
9	Machined Components	211
9.1	General Rules for Machining Technologies	211
9.2	Milled Low Loss Filters	215
9.3	Ring Hybrids and Other Milled Power Dividers	218
9.4	General Enclosures for Encapsulating Electronics	224
9.5	Connector Mounting Considerations	229
9.6	Rotary Joints	231
9.6.1	Basic Waveguide Rotary Joints	233
9.6.2	Swivel Joints	234
9.6.3	Coaxial Rotary Joints	235
9.6.4	Dual Channel Rotary Joints	235
9.6.5	Multichannel Rotary Joints	235
9.7	Case Examples of Precision Machined Microwave Components	237
9.7.1	High-Q SiO ₂ Whispering Gallery Mode Resonator	238
9.7.2	Center Conductor for a Tubular Coaxial Filter	239
	References	240
10	Cutting Processes	243
10.1	Sheet Metal Cutting In General	243
10.2	Water Jet Cut Striplines and Microstrips	246
10.2.1	A Water Jet Cut Ring Hybrid	246
10.2.2	A Water Jet Cut Stripline Feeding Network	249
10.3	Laser Processed Feeding Strips	249
10.3.1	Laser Cutting Process in General	250
10.3.2	A Laser Cut Sharp-Edged Center Conductor	251

10.3.3	Laser Cut Striplines for Low-Loss Interdigital Filters	253
10.4	Tuning Coaxial Transitions	256
	References	259
11	Forming Processes	261
11.1	Extrusion Processes for Metallic Profiles	261
11.2	Selected Processes for Shaping Plastics	264
11.2.1	Injection Molding	265
11.3	Drawing Processes for Wires	266
11.4	Forming Processes for Sheet Metals	267
11.5	Electroforming Process for Corrugated Waveguides	268
	References	269
12	Coating	271
12.1	Basics of Coating Technology	271
12.2	Requirements for Coating Quality	273
12.3	Coating Materials for Microwave Mechanics	273
12.4	Case Examples of Coated Microwave Components	278
	References	282
	Part 3: Examples of Requirements for Mechanical Accessories in Microwave Assemblies	283
13	A Microwave Measuring System for Wood Quality	285
13.1	Description of the Test Arrangement	286
13.2	Transducer Arrangements	289
13.3	Mechanical Requirements for the Measurement System Assembly	291
13.3.1	Serviceability and Easy Access	293
	References	294

14	Antenna Constructions	295
14.1	Basis for the Design of Antenna Constructions	296
14.2	Wind and Ice Loads	297
	References	300
	Part 4: Test Arrangements and Results of Microwave Components Manufactured with Alternative Technologies	301
15	Mechanical Measuring Equipment	303
15.1	Dimensional Uncertainties	303
15.1.1	Measuring Dimensional Uncertainties	303
15.1.2	Measuring Geometric Tolerances	304
15.2	Joint Reliability	310
15.3	Surface Properties	310
15.3.1	Oxide Layers	311
15.3.2	Surface Defects Caused During Manufacturing Processes	311
15.3.3	Mechanical Composition of the Surface Texture	312
15.3.4	Measuring Surface Roughness	313
15.3.5	Friction Measurement	315
15.3.6	Wear Measurement	315
15.3.7	Hardness Tests	317
15.4	Tests for Hermetic Enclosures	317
	References	318
16	Selecting Microwave Test Instrumentation	321
16.1	Vector Network Analyzers	322
16.2	Spectrum Analyzers	323
16.3	Signal Generators	324
16.4	Cables, Connectors, and Some Accessories	325
	References	325

17	Examples of Practical Test Set-Ups	327
17.1	Passive Intermodulation in Welded Components	327
17.2	Testing the Shielding Performance of Microwave Enclosures	329
17.3	Experiments on the Input Impedance of Waveguide to Coax Transitions	330
17.4	Analyzing the Effects of Mechanical Defects on the Performance of Small Phased Array Antennas	332
	References	338
18	Summary	339
	List of Acronyms	343
	List of Symbols	349
	Requirements for Viewing Appendixes A, B, and C	353
	About the Authors	355
	Index	357

Acknowledgments

Many of the results and ideas presented in this book have been collected over the past 3 years during several projects in which other people have participated.

The authors want to gratefully acknowledge Jussi for the technical help and support in computer graphics and e-mail handling. Without his magic tricks, there would be very few illustrations to support the text. Jouni and his skilled team in the workshop made excellent prototypes of selected designs. Special thanks are also given to the anonymous reviewer of the publisher, Artech House, for the careful and detailed suggestions that have improved the accuracy and readability of this book. Senior commissioning editor, Dr. Julie Lancashire stabilized the atmosphere for fruitful discussions. Pekka is deeply impressed by Tuula's care-taking and loving attitude through all the years. Harri wants to give a big hug to his three beautiful cocker spaniels Nome, Taika, and Petra for their patience in waiting their turn every evening during the long writing process.

Finally, the authors want to remember their late father, who gave us both the spirit and opportunity to engage in technical experiments and hard work.

Introduction

Microwaves are generally considered to be a specific part of the wide radio frequency spectrum. The band from 300 MHz to 30 GHz is typically considered to be “microwaves,” for example by the Institute of Electrical and Electronics Engineers (IEEE), although many of us prefer to set the lower limit somewhat higher—perhaps at 1 or even 3 GHz. Above 30 GHz, the term “millimeter waves” is used. High school physics suggests that we are talking about wavelengths ranging from about 30 cm down to 10 mm.

The tremendous growth in mobile communications during the past 10 years has particularly caused a respective increase in the need for microwave and millimeter wave components, devices, and systems. Besides this well-known application area, microwave frequencies are widely in use, for example, in satellite networks, radar and navigation systems, remote sensing, and industrial measurements. Two common features are seen in the latest developments. First, the number of individual units (components or devices) is increasing exponentially, so their production costs should be minimal. At the same time, many of the technical requirements, especially those related to microwave performance, are becoming more and more strict. Higher power levels and lower noise figures should be available, and systems should withstand considerable amounts of mutual interference without noticeable degradation in service quality. In addition to this, weight and size constraints are becoming severe.

In the early days of microwave engineering (back in the 1930s and 1940s), most components were manufactured as highly precise mechanical

elements. This was mandatory, because no semiconductor processes were available nor were there any practical planar circuit board technologies at hand for industrial-scale work. Active devices were mostly electron tubes, which, as such, required the extreme capabilities of the mechanical workshop. Modern microwave components can make use of highly sophisticated semiconductor designs. Miniature-scale planar circuits enable the integration of complete transceivers, such as automobile anticollision radars, into enclosures that are hardly larger than common microwave connectors. The use of mechanical structures, however, will continue. Their necessity as a practical interface between the planar circuits and the macroscopic “real” world is even greater. Devices which call for the lowest loss or which have to handle very high power levels, may well also be “classical” all-metallic components in the future. As long as microwave devices (such as amplifiers, filters, and detectors) are sold as separate items for system integration or prototyping, there will be connectors, waveguide flanges, and a need for microwave mechanics.

Within traditional mechanical engineering, the development of design methodologies has practically stuck to the results already presented in Germany in the 1960s—a lot of work, however, has been done to compose new tools for systematic design. Pahl and Beitz, for example, published their textbooks about systematic design in the 1980s and early 1990s. To show that a lot can still be done to improve the effectiveness of a design process, we will try to highlight useful methodological enhancements related to mechanical microwave components.

This book discusses four important areas of microwave mechanics and is aimed at two distinct audiences. The reader may be a microwave engineer who wants to adapt his or her work to the possibilities and limitations of the mechanical manufacturing processes, tools, and materials. Alternatively, we hope that a mechanical engineer would benefit from the various examples of microwave designs, in which the common practices and rules in his or her “own world” might not give the optimum result. Students of applicable topics should find our presentation useful when preparing themselves for their professional career. Thus, we try to emphasize the cross-technological aspects and also take into account the difficulties of making business successful in this application field.

We want to show the importance of a live connection between the two scientific paths—the electrical and the mechanical one—in getting the best possible results at the lowest cost. First, the typical design procedures and the novel design procedures recently developed by the authors are explained. They are used after having obtained the initial electrical definitions. New ideas are presented to enhance the manufacturability of devices. Because we

have seen that the design for manufacturability and assembly aspects (DFMA aspects) in microwave engineering differ a great deal from the practices of traditional engineering mechanics, we have discussed and explained these subjects through several practical examples. At this stage, we especially want to emphasize that the traditional engineering education does not usually cover the difficult areas of manufacturability related to mechanical microwave components.

Secondly, we show a number of specific manufacturing methods and highlight their capabilities through real test cases. Part three is devoted to various mechanical accessories without which a microwave system can hardly operate. Finally, there are a number of prototypes of complete products and associated measurement results presented in part four. The attached CD-ROM contains most of the test case prototype drawings, which we hope will give inspiration to readers' own trials. First of all, the reader can have a look at some easy-to-open jpg files to get a quick overall impression of each prototype product. In addition, we have produced full, 3-D CAD models with appropriate 2-D documents (compatible with AutoCAD14 and Genius software) of each design example for those designers who would like to continue the design work from where we stopped. It is also possible to pick up necessary data for DXF or STL files from the models for computer-aided manufacturing. True dimensions and material data are given as well.

Page limitations have prevented the inclusion of a number of interesting and important topics that we hope to cover at a later time under a separate title. For example, we would like to give a more thorough treatment of the challenges related to modern design software packages and their interconnections. Depending on the reader's own professional and educational background, we recommend the use of suitable textbooks on either microwave or mechanical engineering fundamentals for support.

Part 1

Design for Manufacturability and Assembly of Mechanical Microwave Components

1

Special Requirements for Microwave Mechanics

The intention of this chapter is to introduce the reader to the world of microwaves (MW), taking into account the appropriate applications and practices required within mechanical engineering. We start by showing a brief systematic treatment of Maxwell's equations. They may look tedious, but they are quite useful. After that, a number of practical cases follow, including examples of material problems and dimensional uncertainties. Next, the basics of radio frequency cables and connectors are briefly described. Finally, a definition of the typical user environment is given.

Some of the most probable electrical imperfections are impedance mismatches of coupling arrangements, in which a perfect alignment and appropriate distances are necessary. Also, dimensions must be optimized and a proper geometry maintained in order to accomplish only one propagating mode with the correct polarization. Imperfections in the cross-sectional structure of a transmission line, misalignments, material dents, severe oxidation, and imperfect joints between adjacent sections will all add attenuation; generate unwanted, so-called higher modes due to strange boundary conditions; distort the polarization patterns; and lower the electric efficiency. The shape and possible deformations of antennas have a great impact on the radiation pattern and the available net gain.

The following discussion will try to show both some theoretical means of estimating the degradations caused by various mechanical defects and also figure out numerical estimates on the relevant parameters.

1.1 Fundamentals of Microwaves

In order to be able to analyze the behavior of a mechanical microwave component and to find the requirements for its manufacturing we must first have a look at the basic elements of electromagnetic wave propagation, transmission line theory, and electromagnetic properties of common construction materials. The aim is to point out that the application of modern design methods will increase the production yield, have a positive effect on microwave performance, and even enable previously unobtainable features. These happen mainly through the improvement of dimensional accuracy. Terms to be defined include:

- Impedance matching of the device towards its input or output;
- 3-D radiation patterns and polarization characteristics, if applicable;
- Losses, attenuation, and modes of propagation;
- Electric shielding performance of the selected construction.

1.1.1 Maxwell's Equations

Let us assume that we have been able to generate a radio frequency wave inside a rectangular metallic tube. This could easily be arranged by using a coaxial connector as a probe through which the electromagnetic energy is converted to a wave. The propagation of this wave is completely governed by the well-known and fundamental Maxwell's equations covering all known electromagnetic fields [1]. In differential form, these equations are

$$\nabla \times E = - \frac{\partial B}{\partial t} \quad (1.1)$$

$$\nabla \times H = J + \frac{\partial D}{\partial t} \quad (1.2)$$

$$\nabla \cdot D = \rho \quad (1.3)$$

$$\nabla \cdot \mathbf{B} = 0 \quad (1.4)$$

where \mathbf{E} is the electric field intensity, \mathbf{H} the magnetic field intensity, \mathbf{D} and \mathbf{B} the electric and magnetic flux densities and ρ the charge density. All parameters are simultaneous functions of time and place in a three-dimensional reference frame, both inside the tube and also after leaving it (e.g., through its open end). In real life, we must supplement this equation set further in order to include the characteristics of the transmission medium. The generalized forms are

$$\mathbf{D} = f(\mathbf{E}) \quad (1.5)$$

$$\mathbf{B} = f(\mathbf{H}) \quad (1.6)$$

$$\mathbf{J} = f(\mathbf{E}, \mathbf{H}) \quad (1.7)$$

Experimental background data must be used here. In many cases, the specific problem is the tight connection with the operating frequency. For a simple linear medium such as air or a vacuum, it is fairly justified to approximate the functions (1.5) – (1.7) with the constants of permittivity ε [F/m], permeability μ [Vs/Am], and conductivity σ [S/m] yielding further to

$$\mathbf{D} = \varepsilon \mathbf{E} \quad (1.8)$$

$$\mathbf{B} = \mu \mathbf{H} \quad (1.9)$$

$$\mathbf{J} = \sigma \mathbf{E} \quad (1.10)$$

In most practical cases, the materials occurring as the transmission medium are nonisotropic depending on their internal microscopic or even molecular structure or the applied processing methods (e.g., pressing of steel). A mathematical solution is hard to find, and even numerical methods do not always work properly. In an anisotropic medium, flux density and field strength are not parallel and ε and μ are tensors. In a vacuum, however, they are simply $\varepsilon_0 = 8.854 \cdot 10^{-12}$ F/m and $\mu_0 = 4\pi \cdot 10^{-7}$ H/m.

1.1.2 General Wave Propagation

Maxwell's equations are somewhat simpler if only free space propagation in empty space is considered, because no currents or discrete charges exist [2].

This is the case when the signal just leaves our rectangular tube and before it enters the target material. Following is a list of the modified functions.

$$\begin{aligned}\nabla \times \mathbf{H} &= \frac{\partial \mathbf{D}}{\partial t} \\ \nabla \times \mathbf{E} &= -\frac{\partial \mathbf{B}}{\partial t}, \text{ at the same time } \begin{cases} \mathbf{D} = \epsilon_0 \mathbf{E} \\ \mathbf{B} = \mu_0 \mathbf{H} \end{cases} \quad (1.11) \\ \nabla \cdot \mathbf{D} &= 0, \\ \nabla \cdot \mathbf{B} &= 0.\end{aligned}$$

If the electric field \mathbf{E} is time-varying, there must be a magnetic field orthogonal to it. This means that both \mathbf{E} and \mathbf{H} must always be orthogonal to each other and with respect to the direction of propagation (the tube z -axis) as well. The wave is either linearly or elliptically polarized. Figure 1.1 shows a principal view of such an electromagnetic plane wave, which exists, however, only in the so-called far field [3].

Let's see what happens if we take a curl of the first equation as

$$\nabla \times \nabla \times \mathbf{H} = \nabla \times \frac{\partial \mathbf{D}}{\partial t} \quad (1.12)$$

Because the time derivative can be moved outside the operator and normally the permittivity is a constant, we obtain

$$\nabla \times \nabla \times \mathbf{H} = \frac{\partial}{\partial t} \nabla \times \mathbf{D} = \epsilon_0 \frac{\partial}{\partial t} \nabla \times \mathbf{E} \quad (1.13)$$

From the latter curl equation we get by substitution $\nabla \times \mathbf{E} = -\mu_0 \frac{\partial \mathbf{H}}{\partial t}$

$$\nabla \times \nabla \times \mathbf{H} = -\mu_0 \epsilon_0 \frac{\partial^2 \mathbf{H}}{\partial t^2} \quad (1.14)$$

Generally, $\nabla \times \nabla \times \mathbf{H} = \nabla(\nabla \cdot \mathbf{H}) - \nabla^2 \mathbf{H}$. Because $(\nabla \cdot \mathbf{H}) = 0$, we have only

$$\therefore \nabla^2 \mathbf{H} = \mu_0 \epsilon_0 \frac{\partial^2 \mathbf{H}}{\partial t^2} \quad (1.15)$$

This is called the wave equation [4], first described by Helmholtz. It defines the magnetic field component of an electromagnetic wave. The

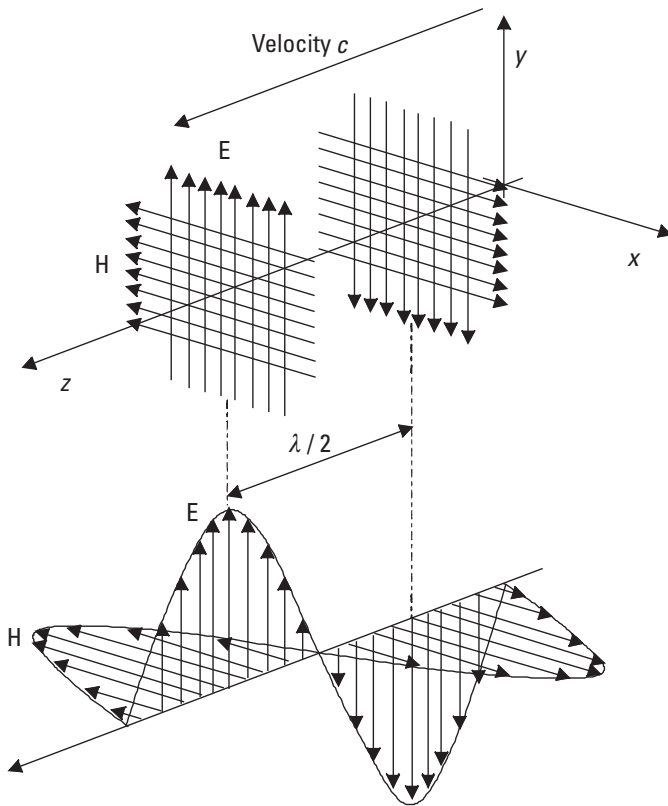

Figure 1.1 The wave propagates in the far field with E and H orthogonal to each other and z -axis. If the signal consists of only one single frequency, the lower illustration is valid, too.

strength of this presentation is in the fact that we have been able to reduce the number of unknowns to one, whereby a closed form solution might be found. A similar expression can be quite easily formulated for the electric field as

$$\nabla^2 \mathbf{E} = \varepsilon_0 \mu_0 \frac{\partial^2 \mathbf{E}}{\partial t^2} = \frac{1}{c^2} \frac{\partial^2 \mathbf{E}}{\partial t^2} \quad (1.16)$$

Here we have used c —the propagation speed of the wave—instead of the material parameters ε and μ . If we want, we can calculate an exact value for c as

$$c = \frac{1}{\sqrt{\mu_0 \varepsilon_0}} = \frac{1}{\sqrt{4\pi 10^{-7} \frac{\text{Vs}}{\text{Am}} \frac{1}{36\pi 10^9} \frac{\text{C}}{\text{Vm}}}} = 3 \cdot 10^8 \frac{\text{m}}{\text{s}} \quad (1.17)$$

which happens to be the velocity of light in a vacuum. Note that a similar discussion is valid for many high quality dielectrics (e.g., Teflon[®]) as well, if other boundary conditions permit.

It is now possible to find a solution for both electric and magnetic fields from the two differential equations if the boundary conditions are known and if the time function is well-defined. Most often, we deal with sinusoidal signals or those that can be assumed to be a sum of several sinusoidal components (as is the Fourier series expansion). Let's assume that we want to produce a wave whose electric field is directed along the y -axis (upwards), that is, we want to have only E_y . This will define the wave propagation outside the tube as well, if isotropic media are considered. The wave equation is further simplified as

$$\frac{\partial^2 E_y}{\partial z^2} = \varepsilon_0 \mu_0 \frac{\partial^2 E_y}{\partial t^2} \quad (1.18)$$

Here, z is assumed to be the along the tube's long, main axis. The solution is known to be a sine wave in the form

$$E_y = \sin(z - vt) + \sin(z + vt) \quad (1.19)$$

For free space propagation (i.e., when the wave is traveling between the tube and the target), we only need one part of the solution, namely

$$E_y = \sin(z - vt) \quad (1.20)$$

where the only trick was to omit the unnecessary physical direction.

1.2 Dimensional Uncertainties

For a lossless transmission line, we can rewrite the solution of the wave equation (1.20) as

$$E_y = \sin\left(z - \frac{1}{\sqrt{\ell \cdot c}} t\right) \quad (1.21)$$

In our case, it is essential to study what happens at discontinuities, for example, when a coaxial transmission line is coupled to a rectangular waveguide, just as in the previous example, or when the rectangular part has dimensional unidealities or the junction to the adjacent sections is not perfect. The transmission line voltage (though virtual in a waveguide) is a function of the z -coordinate. If we define distributed electrical parameters r , l , g , and c for a small (differential) portion of a line, the equation describing the voltage drop is

$$\frac{\partial u}{\partial z} = -ri - l \frac{\partial i}{\partial t} \quad (1.22)$$

Again, as only sinusoidal signals are considered, we get the same

$$\frac{d\bar{U}}{dz} = -(r + j\omega l)\bar{I} = -\bar{Z}\bar{I} \quad [\text{V/m}] \quad (1.23)$$

A current will flow through the conductance and the parallel capacitance

$$\frac{\partial i}{\partial z} = -gu - c \frac{\partial u}{\partial t} \quad (1.24)$$

Using polar (vector) notation we have

$$\frac{d\bar{I}}{dz} = -(g + j\omega c)\bar{U} = -\bar{Y}\bar{U} \quad [\text{A/m}^{-1}] \quad (1.25)$$

If we differentiate (1.23) and (1.25) by z , we get

$$\frac{d^2\bar{U}}{dz^2} = -\bar{Z} \frac{d\bar{I}}{dz} = +\bar{Z}\bar{Y}\bar{U} \quad [\text{V/m}^2] \quad (1.26)$$

$$\frac{d^2\bar{I}}{dz^2} = -\bar{Y} \frac{d\bar{U}}{dz} = \bar{Z}\bar{Y}\bar{I} \quad [\text{A/m}^2] \quad (1.27)$$

The solution is known to be of the form

$$\bar{U} = \bar{U}^+ e^{-\sqrt{\bar{Z}\bar{Y}}z} + \bar{U}^- e^{+\sqrt{\bar{Z}\bar{Y}}z} \quad [\text{V}] \quad (1.28)$$

$$\bar{I} = \bar{I}^+ e^{-\sqrt{\bar{Z}\bar{Y}}z} + \bar{I}^- e^{+\sqrt{\bar{Z}\bar{Y}}z} \text{ [A]} \quad (1.29)$$

By some manipulation, we can show that the current vector in this case will be

$$\bar{I} = + \frac{1}{\sqrt{\bar{Z} / \bar{Y}}} \left(\bar{U}^+ e^{-\sqrt{\bar{Z}\bar{Y}}z} - \bar{U}^- e^{+\sqrt{\bar{Z}\bar{Y}}z} \right) \text{ [A]} \quad (1.30)$$

The ratio $\sqrt{\bar{Z}\bar{Y}}$ is the characteristic impedance of the transmission line (e.g., rectangular waveguide, coaxial cable). Normally, its symbol is \bar{Z}_0 which, with our initial distributed parameters, is

$$Z_0 = \sqrt{\bar{Z} / \bar{Y}} = \sqrt{\frac{r + j\omega l}{g + j\omega c}} \text{ } [\Omega] \quad (1.31)$$

The square root $\sqrt{\bar{Z}\bar{Y}}$ is the propagation constant of the line. It has, in a general case, both a real and an imaginary part

$$\bar{\gamma} = \sqrt{\bar{Z}\bar{Y}} = \sqrt{(r + j\omega l)(g + j\omega c)} = \alpha + j\beta \text{ } [\text{m}^{-1}] \quad (1.32)$$

If the transmission line is not terminated to a suitable load or its own characteristic impedance varies along the z -direction, part of the energy originally propagating towards the positive z -direction will be reflected back. The same will happen if, along a uniform line, structural or dimensional discontinuities occur (e.g., the cross section is changed, the alignment of individual sections is not perfect, or the surface material (inside) is changed), as shown in Figure 1.2 for the example tube.

Having our positional reference at the assumed final load, we have

$$\bar{U}_b = \bar{U}^+ + \bar{U}^- \quad (1.33)$$

$$\bar{I}_b = \frac{1}{\bar{Z}_0} (\bar{U}^+ - \bar{U}^-) \quad (1.34)$$

By combining (1.28) and (1.30) once again with $e^{j\omega t}$ and with (1.33) and (1.34), a new expression for the line voltage is obtained as

$$\bar{U} e^{j\omega t} = \bar{U}^+ e^{-\alpha z} e^{j(\omega t - \beta z)} + \bar{U}^- e^{+\alpha z} e^{j(\omega t + \beta z)} \quad (1.35)$$

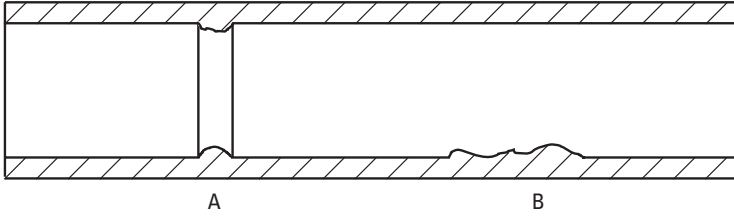

Figure 1.2 A cut showing some possible constructional faults of a waveguide section. At A, a welding joint is intruding far inside the rectangular tube and B has, for example, a corrosion-induced impairment of the surface finish.

and for the current

$$\bar{I}e^{j\omega t} = \frac{1}{Z_0} \left[\bar{U}^+ e^{-\alpha z} e^{j(\omega t - \beta z)} - \bar{U}^- e^{\alpha z} e^{j(\omega t + \beta z)} \right] \quad (1.36)$$

Picking up the actual time functions from (1.35) and (1.36), we get

$$u(t) = U^+ e^{-\alpha z} \cos(\omega t - \beta z) + U^- e^{\alpha z} \cos(\omega t + \beta z + \theta_\rho) \quad (1.37)$$

$$i(t) = \frac{1}{|Z_0|} \left[U^+ e^{-\alpha z} \cos(\omega t - \beta z - \theta_{Z_0}) - U^- e^{\alpha z} \cos(\omega t + \beta z + \theta_\rho - \theta_{Z_0}) \right] \quad (1.38)$$

The line voltage has two components: $\bar{U}^+ e^{-\alpha z}$ and the reflected $\bar{U}^- e^{-\alpha z}$. At a distance l from the reference point, we can define a voltage reflection coefficient ρ and rewrite the voltage and current equations

$$\bar{U}(l) = \bar{U}^+ e^{\gamma l} + \bar{U}^- e^{-\gamma l} = \bar{U}^+ (e^{\gamma l} + \bar{\rho} e^{-\gamma l}) \quad [\text{V}] \quad (1.39)$$

$$\bar{I}(l) = \frac{\bar{U}^+}{Z_0} (e^{\gamma l} - \bar{\rho} e^{-\gamma l}) \quad [\text{A}] \quad (1.40)$$

$$\bar{\rho} = \frac{\bar{U}^-}{\bar{U}^+} \quad (1.41)$$

The virtual impedance seen by the propagating wave on the line is

$$\bar{Z}_b = \frac{\bar{U}_b}{\bar{I}_b} = \frac{\bar{U}^+(1+\bar{\rho})}{\frac{\bar{U}^+}{\bar{Z}_0}(1-\bar{\rho})} = \bar{Z}_0 \frac{1+\bar{\rho}}{1-\bar{\rho}}$$

$$\bar{\rho} = \frac{\bar{Z}_b - \bar{Z}_0}{\bar{Z}_b + \bar{Z}_0} \quad (1.42)$$

Here $\bar{\rho}$ is defined as a voltage reflection coefficient and is based on the (possibly) known actual load impedance [3]. Equations (1.39) and (1.40) can be written in a new form with hyperbolic functions

$$\bar{U}(l) = \frac{\bar{U}^+}{2}(1+\bar{\rho})(e^{\gamma l} + e^{-\gamma l}) + \frac{\bar{U}^+}{2}(1-\bar{\rho})(e^{\gamma l} - e^{-\gamma l})$$

$$\bar{U}(l) = \bar{U}_b \cosh(\gamma l) + \bar{I}_b Z_0 \sinh(\gamma l) \quad [\text{V}] \quad (1.43)$$

$$\bar{I}(l) = \bar{I}_b \cosh(\gamma l) + \frac{\bar{U}_b}{Z_0} \sinh(\gamma l) \quad [\text{A}] \quad (1.44)$$

If the homogenous transmission line length l is known, equations (1.43) and (1.44) give the voltage \bar{U}_a and current \bar{I}_a at the feed point as shown in Figure 1.3.

The line impedance at l is

$$\bar{Z}_a + \bar{Z}(l) = \frac{\bar{U}(l)}{\bar{I}(l)} = \frac{\bar{U}^+(e^{\gamma l} + \bar{\rho}e^{-\gamma l})}{\frac{\bar{U}^+}{\bar{Z}_0}(e^{\gamma l} - \bar{\rho}e^{-\gamma l})}$$

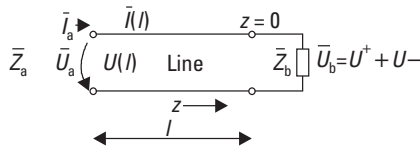

Figure 1.3 Voltage and current on the transmission line with a connected load.

$$\begin{aligned}
 &= \bar{Z}_0 \frac{e^{\gamma l} + \frac{\bar{Z}_b - \bar{Z}_0}{\bar{Z}_b + \bar{Z}_0} e^{-\gamma l}}{e^{\gamma l} - \frac{\bar{Z}_b - \bar{Z}_0}{\bar{Z}_b + \bar{Z}_0} e^{-\gamma l}} \\
 &= \bar{Z}_0 \frac{\bar{Z}_b + \bar{Z}_0 \tanh \gamma l}{\bar{Z}_0 + \bar{Z}_b \tanh \gamma l} \tag{1.45}
 \end{aligned}$$

In a rectangular waveguide, we do not have any meaningful voltages or currents. A characteristic impedance, however, can be obtained in a similar way by comparing electric and magnetic fields (belonging together) and it has been found to be

$$Z = \frac{\sqrt{\mu / \varepsilon}}{\sqrt{1 - \left(\frac{\lambda}{2a}\right)^2}} \tag{1.46}$$

The width of the waveguide cross section is assumed to be a , but the above equation is valid only for the TE_{10} -mode. Besides the two material parameters μ and ε , the impedance is found to be highly dependent on the constructional dimension a .

The numerical value for $\sqrt{\frac{\mu}{\varepsilon}}$ in an air-filled waveguide is very near 377Ω . If we now consider the case when, because of manufacturing imperfections, the waveguide wall has an abrupt 0.5-mm change in width a , we can obtain a numerical estimate on the respective reflection coefficient, see Figure 1.4. The characteristic impedance of section A is

$$Z_A = \frac{377\Omega}{\sqrt{1 - \left\{ \frac{0.02}{2 \cdot 0.0195} \right\}^2}} = 439.1\Omega$$

and that of section B

$$Z_A = \frac{377\Omega}{\sqrt{1 - \left\{ \frac{0.02}{2 \cdot 0.019} \right\}^2}} = 443.4\Omega$$

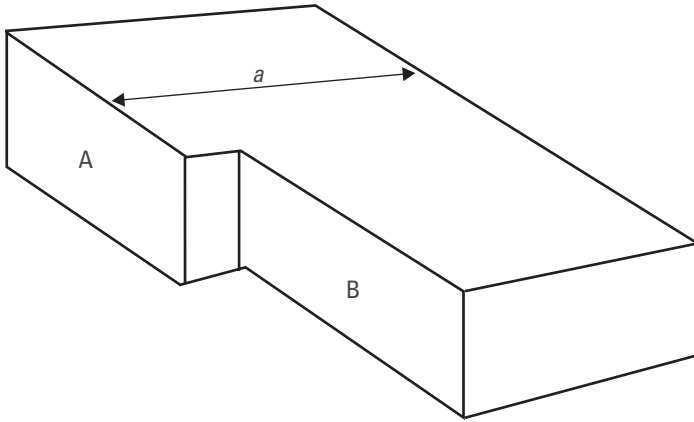

Figure 1.4 An error in the waveguide cross section. The dimension a is assumed to have an abrupt 0.5-mm change between sections A and B.

From these we obtain the voltage reflection coefficient, assuming no other nonidealities

$$\rho = \frac{443.4 - 439.1}{443.4 + 439.1} = 0.085$$

which can further be converted to return loss of 22 dB or standing wave ratio (SWR) of (1.19). SWR indicates the relative amplitude of local voltage maxima in a transmission line due to reflections. If SWR equals one, no reflections occur. The obtained values exceed the critical acceptance limits (return loss 40 dB or SWR 1.1) for a high quality microwave component.

Microwave engineers are used to discussing impedance matters on the Smith chart, which is illustrated in Figure 1.5. The further away from the chart center or the larger the area covered by the impedance locus, the worse the matching is. If and when the whole plot turns to a spot in the middle of the chart, we have obtained a perfect impedance.

An alternative way to discuss impedance matters is to use the amplitude of the scattering parameter S_{11} , which has been done in Figure 1.6. The scalar part of S_{11} tells us how large the amplitude of the signal is, which is reflected back from our component. If S_{11} is near zero (linear scale) or many tens of negative decibels, reflections are minimal. Both presentational forms are readily available in a modern vector network analyzer—a microwave engineer's multimeter.

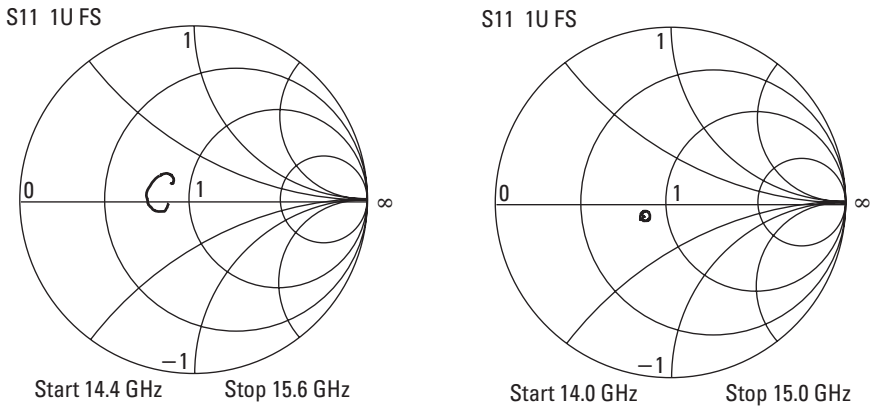

Figure 1.5 Waveguide impedance matching in a Smith chart presentation format. As usual, the optimum target is in the middle of the chart. Normalized resistance and reactance scaling is indicated. The largest bandwidth is shown in the right-hand plot.

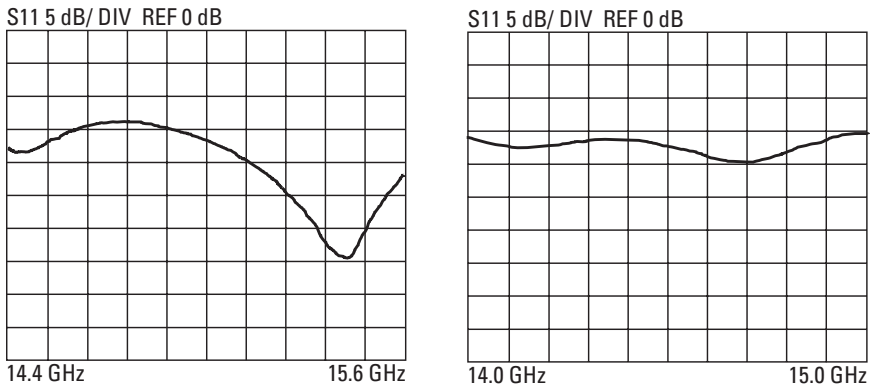

Figure 1.6 Tube return loss as a function of frequency. Note the sharp tuning characteristics of the handmade construction. The industrial version (right) has a usable bandwidth of at least 1 GHz. The upper edge of the scale represents total reflection, 10 dB below it equals one tenth of incident power being reflected back.

1.3 Material Problems

Most practical materials used for microwave devices, such as waveguide and antenna conductors (and insulating materials as well), are not perfect but

have electromagnetic losses. This is the case, for example, when the resistivity of ρ an insulator (dielectric material) does not approach infinity. The electric field inside the material creates a current, which further yields to losses defined as $E \times J$. A very efficient method to handle material losses is by combining permittivity and conductivity [1]. For a sinusoidal plane wave in a medium with permittivity ϵ_r and conductivity σ , we can write

$$\nabla \times H = j\omega\epsilon_r\epsilon_0 E + J = j\omega E \left(\epsilon_r\epsilon_0 - \frac{j\sigma}{\omega} \right) \quad (1.47)$$

and further edit it, by applying the generalized Ohm's law $J = \sigma E$, as

$$\nabla \times H = j\omega\epsilon E \quad (1.48)$$

where

$$\epsilon = \epsilon_r\epsilon_0 - \frac{j\sigma}{\omega}$$

The current density J is initiated by the electric component of the wave inside the medium. By using this complex permittivity, we have obtained a conventional lossless form for Maxwell's equations and, for example, a plane wave can be constructed as

$$E(z) = E_0 e^{-j\beta_0 z} \quad (1.49)$$

Naturally, the propagation or phase constant is also a complex expression.

$$\beta_0^2 = \omega^2 \mu \left(\epsilon_r\epsilon_0 - \frac{j\sigma}{\omega} \right) \quad (1.50)$$

We can divide it in to a real part and an imaginary part.

$$\beta_0 = \beta_{0r} + j\beta_{0i} \quad (1.51)$$

where

$$\beta_{0r} = \omega \sqrt{\mu\epsilon_0} \operatorname{Re} \left\{ \sqrt{\epsilon_r - \frac{j\sigma}{\omega\epsilon_0}} \right\} \quad (1.52)$$

$$\beta_{0i} = -\omega\sqrt{\mu\epsilon_0} \operatorname{Im} \left\{ \sqrt{\epsilon_r - \frac{j\sigma}{\omega\epsilon_0}} \right\} \quad (1.53)$$

If we rewrite the wave solution as

$$E(z) = E_0 e^{-\beta_{0i}z} e^{-j\beta_{0r}z} \quad (1.54)$$

we find that the imaginary part defines the attenuation along the direction of wave propagation. The wavelength is shorter

$$\lambda = \frac{2\pi}{\beta_{0r}} \quad (1.55)$$

The initial plane wave coming towards the medium will be attenuated as

$$\frac{|E(z)|}{|E_0|} = e^{-\beta_{0i}z} \quad (1.56)$$

Let $\delta = 1/\beta_{0i}$. This means that, at a distance δ inside the medium, the electric field has been attenuated by $1/e$ or to about 37% of its initial value. The distance δ is called the penetration depth. If the material conductivity increases, the attenuation will also increase.

1.3.1 A Good Conductor

A good conductor (something we are aiming at with the tube or waveguide walls) has $\epsilon'' > \epsilon'$ where we have divided the permittivity into its real and imaginary parts. The complex propagation constant is $\beta_0^2 \approx -j\omega\mu\sigma$ and

$$\beta_{0r} \approx \beta_{0i} \approx \sqrt{\frac{\omega\sigma\mu}{2}} \quad (1.57)$$

The penetration depth is readily

$$\delta = \frac{1}{\beta_{0i}} \approx \sqrt{\frac{2}{\omega\sigma\mu}} \quad (1.58)$$

We have defined the characteristic impedance for electromagnetic waves as

$$Z_w = \frac{E}{H} \quad (1.59)$$

For a lossy medium, it is a complex quantity that can be shown to be

$$Z_0 = \sqrt{\frac{j\omega\mu}{\sigma + j\omega\varepsilon}} \quad (1.60)$$

For most metals, we can rewrite the equation as

$$Z_s = \sqrt{\frac{j\omega\mu}{\sigma}} = \sqrt{\frac{\omega\mu}{2\sigma}}(1 + j) \quad (1.61)$$

the magnitude of which is

$$|Z_s| = \sqrt{\frac{\omega\mu}{\sigma}} \quad (1.62)$$

Table 1.1 shows values of μ_r and σ_r for typical metals compared to the conductivity of copper $\sigma = 5.8210^7$ S/m and permeability of pure air. More extensive data is available in Chapter 3.

The field strengths E_1 and H_1 at a distance l from the metal surface are, in general form,

$$E_1 = E_0 e^{-1/\delta} \quad (1.63)$$

$$H_1 = H_0 e^{-1/\delta} \quad (1.64)$$

where δ is the previously defined penetration depth of the material and is given by

$$\delta = \sqrt{\frac{2}{\omega\mu\sigma}} \quad (1.65)$$

In (1.65), ω is the angular frequency, μ is the permeability of the medium, and σ is the conductivity; see Figure 1.7.

Table 1.1
Typical Electrical Parameters for Some Common Construction Metals

Material	Relative Conductivity σ_r	Relative Permeability μ_r
Aluminum (soft)	0.61	1
Aluminum (hard)	0.4	1
Copper	1.00	1
Stainless steel (430)	0.02	500
Steel	0.10	1,000

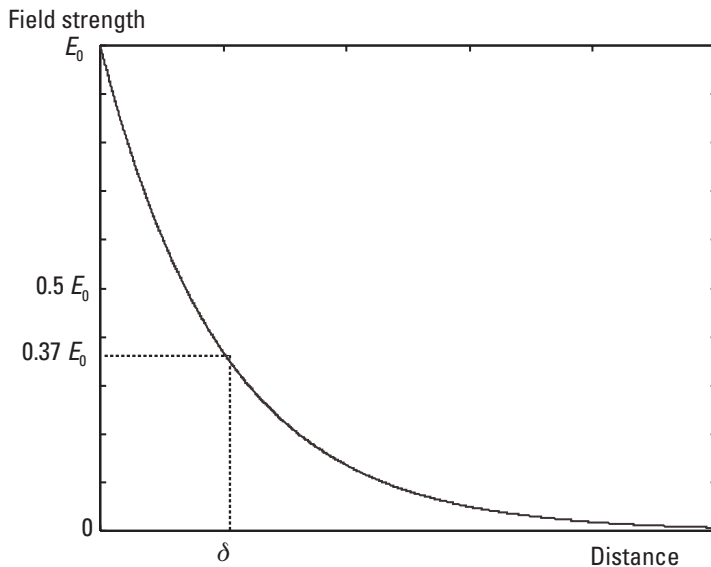

Figure 1.7 Electromagnetic wave penetration in a medium. The distance δ is the penetration depth, where the amplitude has decreased by $1/e$ or about 8.7 dB from the initial value.

1.3.2 Electromagnetic Radiation

The radiation pattern of a passive microwave antenna can be derived straight from Maxwell's equations already shown. Let's look at sinusoidal currents having a frequency $f = \omega/(2\pi)$. All following field equations will thus have one or more components in the $e^{j\omega t}$ presentation. For a general antenna

structure, regardless of its geometry, the pattern function can be derived by first formulating its vector potential $A(\mathbf{r})$ which fulfills the relation

$$\nabla^2 A(\mathbf{r}, t) - \mu\epsilon \frac{\partial^2}{\partial t^2} A(\mathbf{r}, t) = -\mu J(\mathbf{r}, t) \quad (1.66)$$

Applying our sinusoidal assumption we get

$$\nabla^2 A(\mathbf{r}) + \beta_0^2 A(\mathbf{r}) = -\mu J(\mathbf{r}) \quad (1.67)$$

where $J(\mathbf{r})$ is the current density vector. Having $\beta_0^2 = \omega^2 \epsilon \mu$, we can write the solution as an integral in a volume V

$$A(\mathbf{r}) = \mu \int_V \frac{J(\mathbf{r}') e^{-j\beta_0 |\mathbf{r} - \mathbf{r}'|}}{4\pi |\mathbf{r} - \mathbf{r}'|} dV' \quad (1.68)$$

Here, (\mathbf{r}') is the integrand and \mathbf{r} the place where we want to compute the field pattern. Finally, the electric and magnetic fields are obtained from (1.68) by taking its curls as

$$H(\mathbf{r}) = \frac{\nabla \times A(\mathbf{r})}{\mu} \quad (1.69)$$

$$E(\mathbf{r}) = \frac{\nabla \times H(\mathbf{r})}{j\omega\epsilon} \quad (1.70)$$

The previous equations will generally give the radiation pattern of any antenna [5], but their difficulty is in the integration part of the vector potential which seldom has a closed form solution. If the current distribution is known and we are able to limit our study to the near or far field only, some simplifications are usually allowed. For the rectangular tube and an associated pyramidal extension (cross section $a \times b$), a good approximation is [6]

$$\theta_{E_0} = 114.6^\circ \arcsin\left(\frac{\lambda}{b}\right) \quad (1.71)$$

in the E-plane. Respectively, in the H-plane we have

$$\theta_{H0} = 114.6^\circ \arcsin\left(\frac{3\lambda}{2a}\right) \quad (1.72)$$

where the subscripts denote the angle between first pattern nulls. The available gain [7] is estimated as

$$G = 10.2 \frac{ab}{\lambda^2} \quad (1.73)$$

From a manufacturing point of view this turns out to be a very interesting parameter because the maximum achievable gain is also a function of extension (called *horn* in microwave terms) length, but actually a tremendous increase is required just to cover a 1-dB loss due to mechanical imperfections (for example, see Figure 1.8).

From (1.70) it is possible to find a numerical value for the change in the pattern beamwidth due to an imperfection in the aperture. If the increased width is, let's say, 45 mm, we have

$$\theta_{E0} = 114.6^\circ \arcsin\left(\frac{0.02}{0.045}\right) = 52.8^\circ$$

and for a nominal width of 44 mm the angle will be

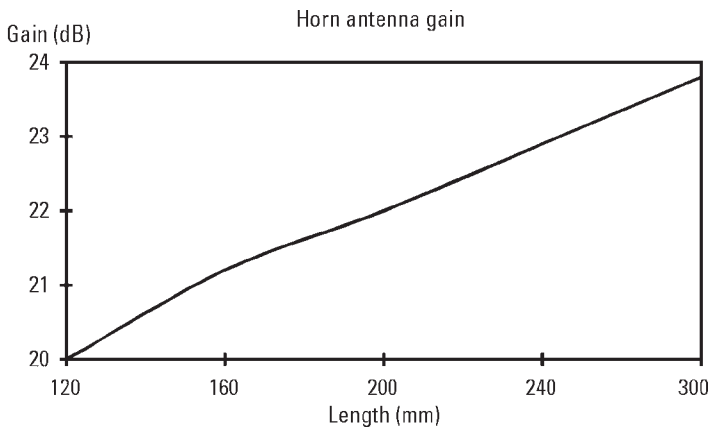

Figure 1.8 The total length of a rectangular horn antenna must be extended by 50% in order to cover a 1-dB loss due to, for example, a mechanical imperfection.

$$\theta_{E_0} = 114.6^\circ \arcsin\left(\frac{0.02}{0.044}\right) = 54.1^\circ$$

Thus, the change in pattern width is about 1.3° , which does not ruin the performance but can still be annoying (e.g., in parabolic feeds). A practical example is illustrated in Figure 1.9, where two different rectangular constructions are compared. It also turns out that, for example, pattern performance is—after tedious attempts—a compromise.

1.3.3 Electromagnetic Waves Initiated by Cavities

In a rectangular waveguide (like the one already discussed), we normally have a wave propagating along its longitudinal axis (z). The wave will also have transverse phase coefficients β_{0x} and β_{0y} which together with β_{0rz} fulfill the equation

$$\beta_{0x}^2 + \beta_{0y}^2 + \beta_{0rz}^2 = \beta_0^2 = \omega^2 \mu \epsilon \quad (1.74)$$

We notice that β_{0rz} is a real number only if the transversal constants are small enough or if the frequency is high enough. The limiting value is found when $\beta_{0rz} = 0$ and

$$\beta_{0x}^2 + \beta_{0y}^2 = \beta_0^2 \quad (1.75)$$

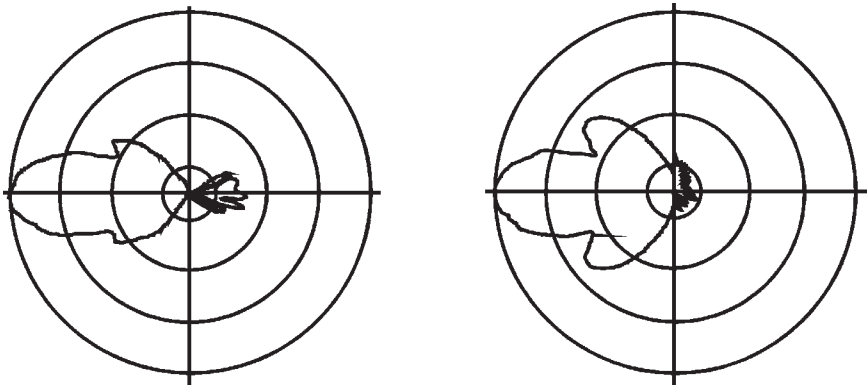

Figure 1.9 The elevation patterns of two different rectangular horn antennas differ greatly. The lower back lobe level (right) obtained with the more accurate technology is particularly noteworthy. Note also the change in the sidelobes.

In a rectangular waveguide, for mode m, n the cut-off frequency (below which no propagation happens) is

$$f_{c,mn} = \frac{1}{2\pi\sqrt{\mu\varepsilon}} \sqrt{\left(\frac{m\pi}{a}\right)^2 + \left(\frac{n\pi}{b}\right)^2} \quad (1.76)$$

Here a is the width of the waveguide and b is the height; see again Figure 1.4.

The subscripts m and n are used to identify different modes in the waveguide. Generally, a waveguide may simultaneously support several modes, but, from a specific application's point of view, this is the most undesirable situation. Figure 1.10 shows two possible arrangements used to couple electromagnetic energy from a coaxial cable to a rectangular waveguide—either by a short rod or by a tiny loop. The dominating mechanism (electric or magnetic) is readily visible.

Let's further consider the rectangular waveguide with width larger than height, that is $a > b$. The fundamental, wanted mode is TE_{10} , for which β_c is

$$\beta_c = \sqrt{\left(\frac{m\pi}{a}\right)^2 + \left(\frac{n\pi}{b}\right)^2} \quad (1.77)$$

But now $m = 1$ and $n = 0$ and thus

$$\beta_c = \beta_{0x} = \frac{\pi}{a} \quad (1.78)$$

This result can be interpreted to show that the phase angle of the wave will rotate 360° in the waveguide after a distance $2a$. Let's find a numerical

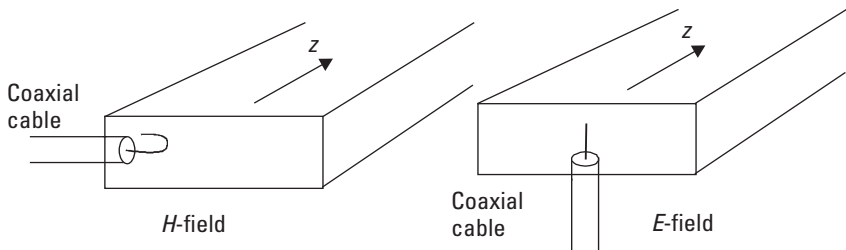

Figure 1.10 Feeding a rectangular waveguide with a short rod or with a small loop, both connected to a coaxial cable.

solution that shows the effect of a mechanical uncertainty in the transducer design.

If the upper width of the transmission line is 88 mm and the lower (bottom) width only 87 mm, after traveling the full waveguide length of about 100 mm, the phase difference (in radians) would be

$$\Delta\phi = \frac{\pi}{88} 100 - \frac{\pi}{87} 100 = -0.041$$

or 2.4° . This would noticeably deteriorate the sidelobe performance of the final design—if used as an antenna, because the polarization plane, which ought to be perpendicular to the waveguide bottom surface, will be tilted by the same amount.

The electric and magnetic fields are

$$E(\mathbf{r}) = jE_0 \sin \frac{\pi x}{a} e^{-j\beta_{0r}z} \quad (1.79)$$

$$H(\mathbf{r}) = -i \frac{\beta_{0r}}{\mu\omega} E_0 \sin \frac{\pi x}{a} e^{-j\beta_{0r}z} + k \frac{\beta_c}{\mu\omega} E_0 \cos \frac{\pi x}{a} e^{-j\beta_{0r}z} \quad (1.80)$$

An important result is the fact that the electric field only has a component in the y -direction and it is zero on the vertical, perfectly conducting walls. The phase constant can also be expressed, in terms of the cut-off frequency [8], as

$$\beta_{0r} = \sqrt{\beta_0^2 - \beta_c^2} = \beta_0 \sqrt{1 - \left(\frac{\beta_c}{\beta_0}\right)^2} = \beta_0 \sqrt{1 - \left(\frac{f_c}{f}\right)^2} \quad (1.81)$$

where β_0 is naturally defined as

$$\beta_0 = \omega\sqrt{\epsilon\mu} \quad (1.82)$$

The actual cut-off frequency is (for this mode)

$$f_c = \frac{\beta_c}{2\pi\sqrt{\mu\epsilon}} = \frac{1}{2a\sqrt{\mu\epsilon}} \quad (1.83)$$

We can use this observation to study the effect of a nonperfect welding joint along the side of a rectangular waveguide as depicted in Figure 1.11. Let us assume (for reasons of computational simplicity) that the groove is 30 mm long.

The dielectric is air, so that we can calculate the phase constant from μ_0 and ϵ_0 . The transversal phase constant is (since the cut-off frequency is 5,000 MHz)

$$\beta_c = \frac{\pi}{0.03\text{m}} = 105 \frac{1}{\text{m}}$$

If the actual operating frequency inside the waveguide is 15 GHz, its phase constant β_0 is

$$\beta_0 = \frac{2\pi}{\lambda_0} = \frac{2\pi}{0.02\text{m}} = 314 \frac{1}{\text{m}}$$

$$\beta_{or} = \sqrt{\beta_0^2 - \beta_c^2} = \sqrt{87571} \approx 296 \frac{1}{\text{m}}$$

The β_{or} value is positive, we have (theoretically) no attenuation at all, and the wave will escape from the tube (waveguide) through the unintentional hole. If, on the other hand, we have a small rectangular hole in the welding joint, say about 0.5 mm in width, we can assume its behavior in a similar way and get, for the lowest mode TE_{10} , a phase constant $\beta_c = \frac{\pi}{0.005\text{m}} = 628 \frac{1}{\text{m}}$ and $\beta_{or} \approx j544 \frac{1}{\text{m}}$. The attenuation is e^{-544}/m , or 4,725 dB/m. If again the material thickness is 1 mm, the net attenuation will be roughly 4.7 dB, which means that quite a large amount of energy will be lost through the small hole.

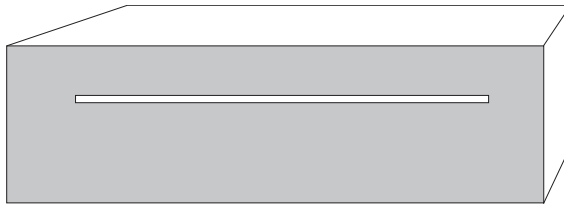

Figure 1.11 A narrow groove in the sidewall of a rectangular waveguide.

In case the waveguide walls have a nonperfect conductivity, an additional attenuation must be taken into account. If we formulate all field components as

$$E = E_0 \cdot e^{-\alpha z} \quad (1.84)$$

where the attenuation constant α can be shown to be

$$\alpha = \frac{0.5a \sqrt{\frac{\pi f \mu_2}{\sigma_2}} \left\{ 1 + \frac{\beta_{01}^2 a^2}{\pi^2} \right\} + b \sqrt{\frac{\pi f \mu_2}{\sigma_2}}}{0.5ab \frac{\beta_{01} a^2 \omega \mu_1}{\pi^2}}, \quad (1.85)$$

a quite accurate mathematical presentation has been accomplished. Further additions are needed, however, if the oxidation effects and losses due to the excitation of unwanted higher modes are also to be considered.

1.4 Connection Philosophies

Many microwave modules are designed, manufactured, and sometimes even used as physically separate items and thus their interconnections need special attention. Partly based on operating frequency or power, and partly on simple cost issues, the fundamental approach is different from case to case. Below 2 to 3 GHz, coaxial connections are preferred and they are usable up to about 28 GHz, some to 40 GHz. Commercially available standard devices are utilized and the end user's main task is to make a proper choice. If, however, the frequency is or approaches the millimeter wave range, only waveguides (either rectangular or elliptical) can be used. Here we have to cope with the layout problem and often have to provide the actual guide itself as an integral part of the main module (e.g., a filter). Well-defined but dimensionally exotic flanges are used as mating surfaces between items and the question of the correct mode must be handled.

Planar designs, such as certain antennas and transducers, can make use of either stripline or microstrip technology. No special connectors are available (nor would they be feasible either) and thus a transition is needed as an interface. At lower microwave frequencies, it is more practical to try and construct a coaxial connection as long as the overall dimensions of the connector stay small compared to fractional wavelength (usually 25%). Naturally, as

long as all the items in the mechanical arrangement are of the same line structure, no connectors should be used.

1.5 Typical User and Application Profiles

Mechanical microwave components are needed in a most diverse set of applications and systems. The expanding mobile communications business uses them as antennas, filters, and duplexers. Many high-power broadcasting transmitters and radar devices are not possible at all without sturdy, mechanical radio frequency (RF) blocks, which include microwave circulators and power dividers or combiners. Even more interesting are the numerous “combined” components in which part of the electronic functionality relies on the physical dimensions, shapes, and materials. Typical examples are microwave and millimeter wave transmitter tubes (e.g., magnetrons and klystrons) and resonator cavities.

Essential features required in a mechanical microwave component are relatively stringent tolerance grades, less common (for mechanical engineering, at least) materials, and—depending on frequency of operation—minimal overall sizes. Although certain devices for the cellular networks have obtained huge quantities, a special microwave module may be manufactured only in a series of tens or hundreds of units. Highly sophisticated items, such as precision resonators for atomic clocks, are unique designs, but naturally their production costs are scaled accordingly.

References

- [1] Pyrhönen, J., *Electromagnetic Compatibility*, Lappeenranta, Finland: LUT, 1998.
- [2] Dolukhanov, V., *Propagation of Radio Waves*, Moscow, Russia: Mir Publishers, 1966.
- [3] Ramo, Whinnery, and van Duzer, *Fields and Waves in Communication Electronics*, London, England: John Wiley, 1966.
- [4] Collin, R., *Foundations for Microwave Engineering*, London, England: McGraw-Hill, 1992.
- [5] Kraus, J., *Antennas*, New York: McGraw-Hill, 1966.
- [6] Jasik, H., *Antenna Engineering Handbook*, London, England: John Wiley, 1968.
- [7] Johnson, R., *Antenna Engineering Handbook*, London, England: McGraw-Hill, 1992.
- [8] Matthaei, Young, and Jones, *Microwave Filters, Impedance Matching Networks and Coupling Structures*, Norwood, MA: Artech House, 1992.

2

Systematic Flowchart Model

Systematic design is a specific methodology consisting of sequential, well-defined steps or phases of the design process that is used to rationalize the task. The systematic approach is usually presented accompanied by a schematic flowchart. The stated principles are used to find solutions for design problems and to make it easy to combine different solutions as needed. The expression *design for manufacturability* (DFM) includes methods for choosing the most appropriate construction of an item for production, instructions or rules to design the product for easy manufacturing, and means to improve cooperation and integration between design and manufacturing. Additionally, *design for manufacturability and assembly* (DFMA) is used to underline the importance of assembly stages in production.

2.1 Principles of Systematic Design

To be able to use any systematic approach, it is first necessary to determine the goal, which is divided into subgoals. Secondly, the requirements, boundary conditions, and other constraints are needed to direct the design process. These factors can concern functional, geometric, dimensional, or material properties. Thirdly, it is essential at the beginning of the design process that all solution ideas are initially acceptable. This will enable the designers to use their creativity in finding as many solutions as possible. To aid this process, it may be useful to employ several means to help the designer, such as

brainstorming, Method 635, the Gallery method, and the Delphi method or synetics [1]. In Method 635, each participant in a group of six members composes three ideas and then tries to improve the ideas composed by the other five participants. In contrast to this, the Gallery method, allows all the members to make drafts and compose free ideas from them. The Delphi method is a more advanced approach in which experts deal with specified questions and problems and evaluate possible solutions for them. Further, all the variants for making new combinations of known solutions must be collected. Success depends on the thoroughness in collecting the range of ideas and variants beforehand. This is followed by an evaluation. Finally, the design process includes a number of decisions. There are at least a few ideas, usually, that seem promising for further development.

The flow of work during the systematic design process is usually dealt with in four main phases [1]:

- Planning and clarifying the task: specification of information;
- Conceptual design: specification of principle;
- Embodiment design: specification of layout (construction);
- Detail design: specification of production.

Different researchers either emphasize their own weightings of specific steps and phases of the design process or present their own methodologies for a systematic approach. Even though these research results have been useful for improving the design methodology itself, some misunderstandings have resulted from the wide range of applied terminology. This problem is especially evident in the translated literature (see, for example, the differences between [1] and [2]).

Probably the most important German researchers of engineering design methodology are Pahl and Beitz [1], Hansen [3], Müller [4], Roth [5], Rodenacker [6], Hubka [7], and Koller [8]. They all emphasize the importance of step-by-step analysis and systematic approach. Rodenacker's approach, however, differs from the others because he illustrates the systematic design approach more as a physical process. According to his model, the working structure can be solved through logical, physical, and constructive relationships. In his model, binary logic is used to describe aspects of "connecting" or "separating." For those readers who are interested in the historical stages of development of systematic design approaches, the references [1–8] might be useful.

The most famous researchers outside of Germany are Oakley [2], Cross [9], French [10], Lanigan [11], Glegg [12, 13], Nadler [14], Eppinger [15–23] and his team, and Ishikawa [24–25]. Most of these researchers consider the design work as a more open process in which a tightly systematic approach might not be the best way to reach cost-effective results. Japanese researcher, Ishikawa, of course, presents the common, quality-oriented approach. For those readers who would like to extend their knowledge about engineering design methodology, references [2, 9–23] are highly recommended. From these references, it might be possible to get another opinion about how to improve the effectiveness of the design stages of a product.

From the point of view of MW mechanics, it is useful to try to take advantage of the results of previously listed researchers. In fact, in the methodology presented in Section 2.2, we try to utilize the best properties of each methodology and combine these properties with the novel data collected during the last few years from MW industry.

2.1.1 Some Assisting Tools

Simultaneous with the development of design methodologies, different assisting tools have also been introduced to help the systematic approach.

The systematic approach to the design of technical systems and products is presented in, for example, Verein Deutscher Ingenieure (VDI) 2221 [26]. Figure 2.1 presents the general approach to design according to VDI 2221. Typical to this approach is the underlining of several iterative steps backward or forward, which is of course useful to find the optimal solution but which might well increase the total time used in the design process. This flowchart is meant to be just a guideline and an assisting tool for the designer during the process.

Another general assisting tool dealing with the whole design process is the well-known value analysis (VA). It is described in detail in, for example, standard Deutsche Industrie Norm (DIN) 69910. The main purpose of VA is the reduction of costs during the various phases. More specific assisting tools include numerous discursive or intuitive methods that have been developed directly to support the systematic design process.

Typical methods for solution finding are:

- Questionnaires and checklists;
- Dividing the problem to easier subproblems;
- Method of divergent thought (starting from the first possible solution, as many new solution paths as possible are sought);

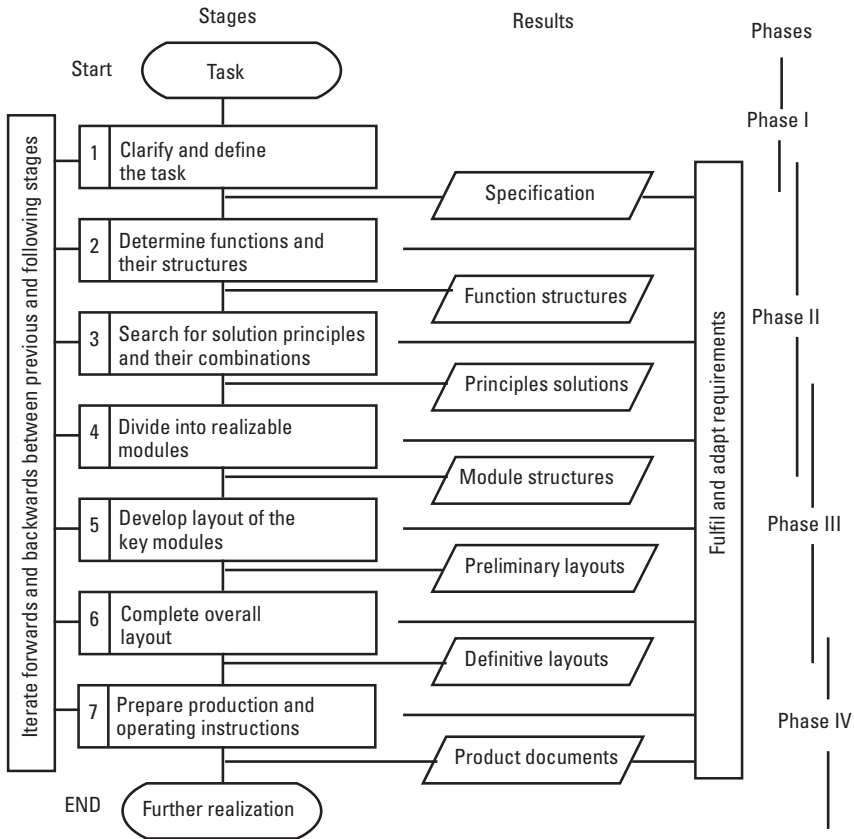

Figure 2.1 General approach to design according to VDI Guideline 2221.

- Method of convergent thought (the search for a solution starts from the goal not from the initial problem);
- Systematic variation (for example, the use of design catalogues or classification schemes).

To make the evaluation phase more effective, the following intuitive documented methods can be used: brainstorming, Method 635, Gallery method, Delphi method, synetics, creative design [27], and design for function (similarities taken from nature) [10].

When designing MW mechanics, it has been proven that, even though these assisting tools really produce several ideas for evaluation, it is essential

to point out that the real value of the ideas depends highly on the expertise of the design group. The members of a typical design group for MW mechanics are rarely experts on manufacturing technology, which means that the solution ideas come from a very narrow area. On the other hand, the expert on mechanical engineering or manufacturing design does not have enough knowledge of microwave mechanics to be able to solve the design problems. Therefore, the need for a detailed questionnaire for the design process of microwave mechanics is emphasized. The lack of design catalogues was also observed.

2.1.2 List of Requirements

The list of requirements is the design specification compiled after clarifying the task. When the list is written, the requirements are divided into two groups: wishes and demands. Pahl and Beitz [1] suggest that the main headings of the requirement list could be as follows: geometry, kinematics, forces, energy, material, signals, safety, ergonomics, production, quality control, assembly, transport, operation, maintenance, recycling, costs, and schedules.

During the design processes of the MW components presented in this textbook, several requirement lists were made and the same problem came up each time: which way would be the most cost-effective for defining the manufacturing aspects. If the requirement list has a demand for a specific manufacturing process, it will cause many boundary conditions for other properties. If, however, the manufacturing aspects are completely left out of the requirement list and if the manufacturability analysis is the last step of the process, then it is probable that at least one iterative redesign cycle will be needed. The third possibility is to select the manufacturing method initially and adapt the other requirements with it. This cannot satisfy the functional requirements and is therefore impossible. It is necessary to recognize the most cost-effective manufacturing process in the early stages of a design process and, after that, to direct the design to satisfy both the functional requirements and manufacturability aspects without iterative, time-consuming redesigns.

The difficulty of converting the task clarification into the concrete requirements of the product has been proved several times. Koller [8] supports this finding in general by classifying the steps of product description and task clarification of the most complex paths of the process. One typical example of confusing requirements from the world of MW mechanics was the case where geometrical tolerances for a plane (requirements for manufacturing accuracy) were determined by the boundary conditions (here, a real

physical boundary such as the metallic wall of a waveguide) for electromagnetic wave propagation.

2.2 Advanced Methodology for Designing Microwave Mechanics

The main reason for developing new design methodologies is to improve the efficiency of engineering design. In practice, as verified during this research, there are six different points of view covering this subject (further illustrated in Figure 2.2):

1. Making organizational changes (e.g., teamwork, and relationships between designers);
2. Knowledge level (e.g., necessary education, knowledge about modern manufacturing technologies);
3. Improving the design environment and ergonomics;
4. Personal character and skills (abilities for creative design and team work);
5. Possibilities of utilizing additional design methods and tools (e.g., computer-aided tools);

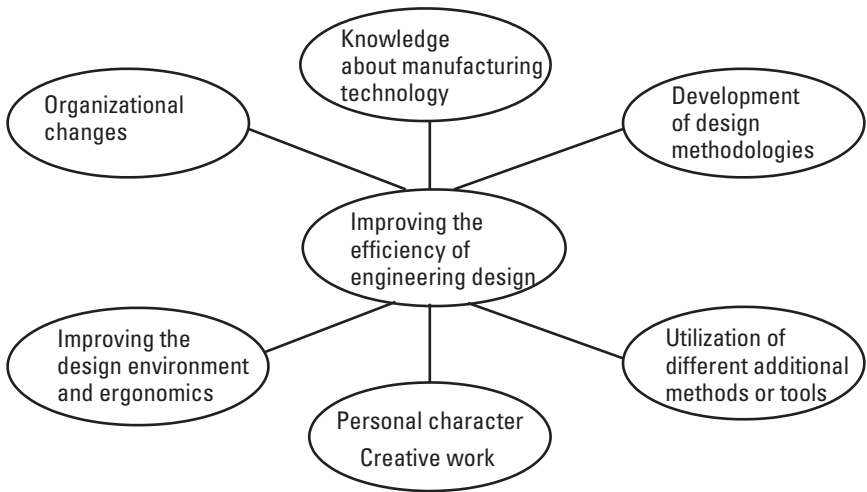

Figure 2.2 Means of improving the efficiency of engineering design are divided into six groups.

6. Possibilities of tuning the design methodologies or combining the best stages from already know methodologies for a specific design area.

2.2.1 Basic Elements of the Advanced Methodology

The suggested advanced or “tuned” design methodology, as we have named it, for laser processing (TDMLP) consists of six basic elements. Laser processing is used as an illustrative case in the following list of elements (see also Figure 2.3):

1. To meet the special requirements of microwave mechanics, a tuned requirement list is needed. In Table 2.1 a preliminary questionnaire

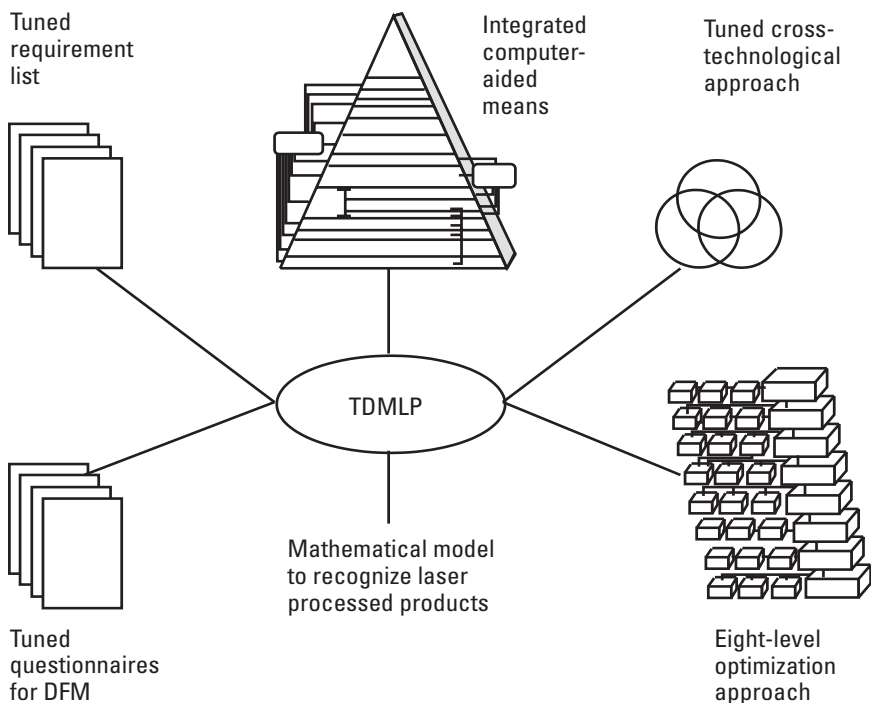

Figure 2.3 The six basic elements of the tuned methodology are: (1) a tuned requirement list, (2) a cross-technological approach, (3) the use of a mathematical model to recognize laser processed products during the early stages of design, (4) tuned questionnaires for DFM, (5) a computer-aided design environment, (6) the eight-level optimization approach, and [28].

Table 2.1

A Preliminary Questionnaire for Helping to Form the Requirement List of Mechanical Microwave Subassemblies

Question	Answer
1. What is the expected operating frequency?	_____ GHz
2. What is the required relative bandwidth?	_____ %
3. What is the maximum radio frequency power to be handled?	_____ dBm
4. Will the unit a) receive (RX), b) transmit (TX), or c) do both?	a) b) c)
5. What is the absolute maximum attenuation allowed?	_____ dB
6. Are semiconductor components involved in the design?	yes no
7. Is the preferred transmission line a) waveguide, b) planar, c) coaxial, or d) dielectric?	a) b) c) d)
8. Should the connection to adjacent modules go through a) coaxial connectors, b) waveguide flanges, or c) neither?	a) b) c)
9. Is the unit a) sealed for life, or b) should there be a possibility for service and repair?	a) b)

From: [29].

for helping to form this tuned requirement list of mechanical microwave subassemblies is established. Any creative tools presented within the traditional systematic design approach to find new product ideas and instructions to fill requirement lists, however, can be used in the beginning of this methodology.

2. Teamwork according to the cross-technological approach should start from the beginning of the design process. Experts on microwave mechanics, engineering design, manufacturing technology, and laser processing are the most important members. In the beginning of the design process, other members are less vital.
3. To avoid useless redesign cycles, a mathematical model is used in order to recognize the products to be laser processed as soon as possible after the first product ideas are found. For example, any decision making process with a suitable mathematical presentation can be utilized.
4. Tuned questionnaires are used to establish the special DFM requirements of laser processing (see Table 2.2) simultaneously with the functional requirements of microwave mechanics (see Table 2.1).

Table 2.2
Special DFM Questions for Laser Processing, Illustrative Examples

Question	Implementation	
1. Are the possibilities of using the fixturing systems for machining considered? (Typically the requirements of accuracy of fixturing in laser processing and machining are almost equal.)	yes	no
2. Could the carbon content of steel be kept under 0.2% (or at least not higher than 0.3%)?	yes	no
3. If highly reflective materials are welded (for example, Cu- and Al-alloys), is the utilization of Nd:YAG recommended in design documents?	yes	no
4. Are the joint preparations for laser welding documented including necessary tolerances and manufacturing methods? (Laser cutting or machining are recommended, however R_a 12.5 μm is appropriate.)	yes	no
5. Are butt welds with raised edges, or lap joints with seam welds used whenever it is possible due to constructional aspects?	yes	no
6. Are more than two plates welded with the same (seam) weld whenever it is possible due to constructional aspects?	yes	no
7. Is it possible for the construction to be laser processed from one direction or at least in one plane?	yes	no
8. Are the values for air gap and allowed misalignment marked in the design documents (for example, butt joint/air gap 0.15 mm, $t < 10$ mm, misalignment < 0.3 mm)?	yes	no
9. If the material's hardenability properties must be taken into consideration, is the most appropriate joint geometry utilized? (For example, the weld is placed mostly on the plates to be welded.)	yes	no
10. If wires or strings are welded, are the most appropriate joint types used? (Power density should be dealt equally to the parts to be joined.)	yes	no
11. If jigs are needed, are the fixturings of jigs designed and marked on the drawings? (in case the workpiece is moving in front of the beam)	yes	no
12. Is the need for grinding the reinforcement marked in the drawings if several sheet metal constructions are welded together?	yes	no
13. When jigs are needed for welding partially closed structures, is the possibility of shrinking taken into account when removing the workpiece?	yes	no
14. Is the possibility of using various material combinations considered?	yes	no
15. Are the possibilities of using different laser processing methods for the same construction or multiprocessing methods considered?	yes	no
16. Are the points where laser welding starts and ends designed to meet quality aspects?	yes	no

Table 2.2 (continued)

Question	Implementation	
17. Is the CAD geometry of the workpiece saved in the DXF format (or another suitable format) for CAD/ computer-aided manufacturing (CAM) integration?	yes	no
18. Are the traditional instructions for designing sheet metal parts taken into account? (for example, those needed for cut-bend-weld multiprocessing)	yes	no
19. Are the adjusting holes or fits marked on the drawings? (or are other additional geometries necessary for adjusting the parts together)	yes	no

From: [30].

5. A computer-aided environment is utilized from the beginning of the design process. In practice, it is essential to avoid modeling the same computer-aided design (CAD) geometry several times for different purposes and to ensure that data from the CAD geometry can be transformed without any additional editing for example in DXF or STL format for laser processing.
6. The design process is carried out inside the eight-level optimization approach starting from the top level and ending at the bottom.

The context of the six basic elements of the tuned methodology is clarified in Figure 2.4. The design process is carried out inside the eight-level optimization approach (the largest arrow in Figure 2.4). The design task presented by the customer is an input to the process. Two long, direct-axis arrows illustrate that both the cross-technological teamwork and the use of computer-aided means are carried out during the whole design process in the same design environment. The small arrows in the middle of the process (tuned lists and questionnaires, mathematical model, and creative means) describe the individual main stages necessary for successful design work. The scope of computer-aided means and teamwork must be evaluated during the process. If needed, there are good possibilities for utilizing, for example, artificial intelligence (AI) applications, World Wide Web (WWW) applications, and concurrent engineering. The output of the process is the readiness for laser processing (and the final product). In Table 2.3 there are three illustrative examples of how the tuned requirement list can be used to assist the design process.

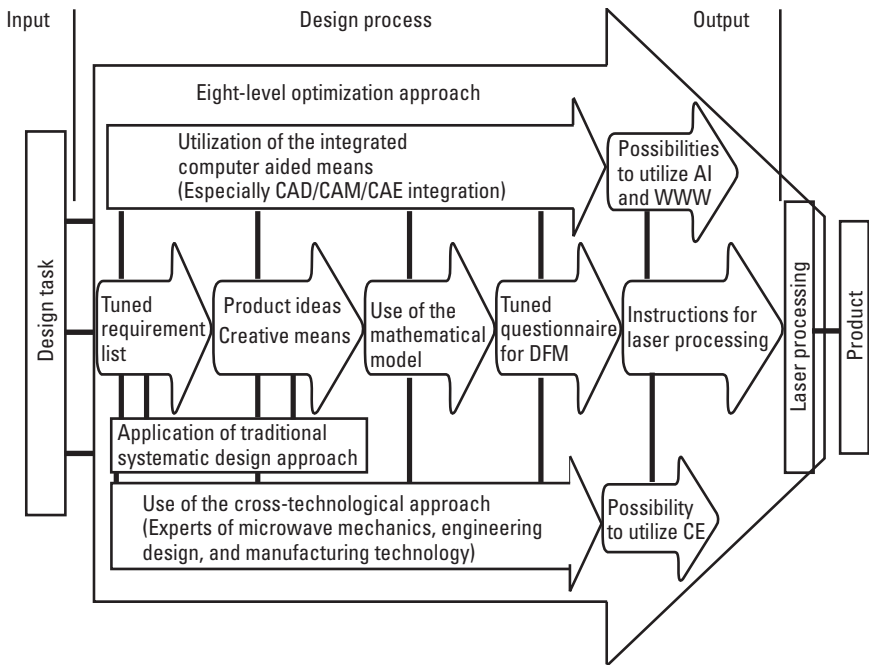

Figure 2.4 The context of the six basic elements of the tuned methodology, with an application to microwave mechanics.

2.2.2 Flowchart Presentation of the Tuned Methodology

Finally, in Figure 2.5, we illustrate a flowchart of the tuned design methodology for laser processing which includes manufacturability analysis and, furthermore, the tuned analysis for laser processing (outlined with a dashed line). The analysis presented in Figure 2.5 is for laser welding of microwave components. This procedure will be analogical, however, if any other laser processing method is used.

The tuned methodology has some similarities to the traditional systematic design approach in the beginning, where the requirement list for microwave components is collected and new product ideas are produced through creative means. There is some convergence with concurrent engineering in the middle of the propagation of the methodology: An important part of the methodology is the stage where, with the help of computer-aided means, the product, manufacturing process, and fixturings are simultaneously designed. The teamwork, however, is confined inside a group that has experts on microwave mechanics, engineering design, manufacturing technology, and

Table 2.3
Case Examples of Using the Tuned Requirement List

Question Number	Answer	Consequences
Is the preferred transmission line a) waveguide, b) planar, c) coaxial, or d) dielectric?		
7	a	Metal construction preferred, best performance for microwave, heavy constructions
7	b	Both air-dielectric metal and substrate-based designs are possible, light constructions
7	c	Supporting insulators are necessary, connectors available only for standardized cross-sectional dimensions, large dimensions for high power applications
7	d	Composites only, supporting structures are critical
What is the expected operating frequency?		
1	1 GHz	Generally any material, dimensional tolerances > 1 mm
1	GHz	Most metals, including steel, but oxidation is to be avoided; surface and alignment tolerances generally < 0.1 mm
1	15 GHz	Only highly conductive metals (Cu, Au), most impurities extremely harmful, tolerances possibly 5 to 10 μm
What is the maximum radio frequency power to be handled?		
3	+30 dBm	Heat is typically less important
3	+60 dBm	Heat must be transferred away, nonmetallic parts may suffer, corrosion generally accelerated
3	+60 dBm	Active cooling necessary, arcing highly possible, some metals may reach an unstable temperature, severe corrosion

From: [30].

laser processing. The other members, as stated in concurrent engineering, are not necessary during the early design stages. On the other hand, the methodology shown in Figure 2.5 includes mostly new aspects for manufacturing analysis. The most important stages, that were previously less well known, are marked in the flowchart with a colored background.

Firstly, it is essential to notice that the search for characteristics for specific manufacturing methods is done immediately after finding the first product ideas. By using a mathematical model, which is based on the evaluation of the known characteristics of different manufacturing methods, it is possible to recognize the most appropriate product ideas for laser processing.

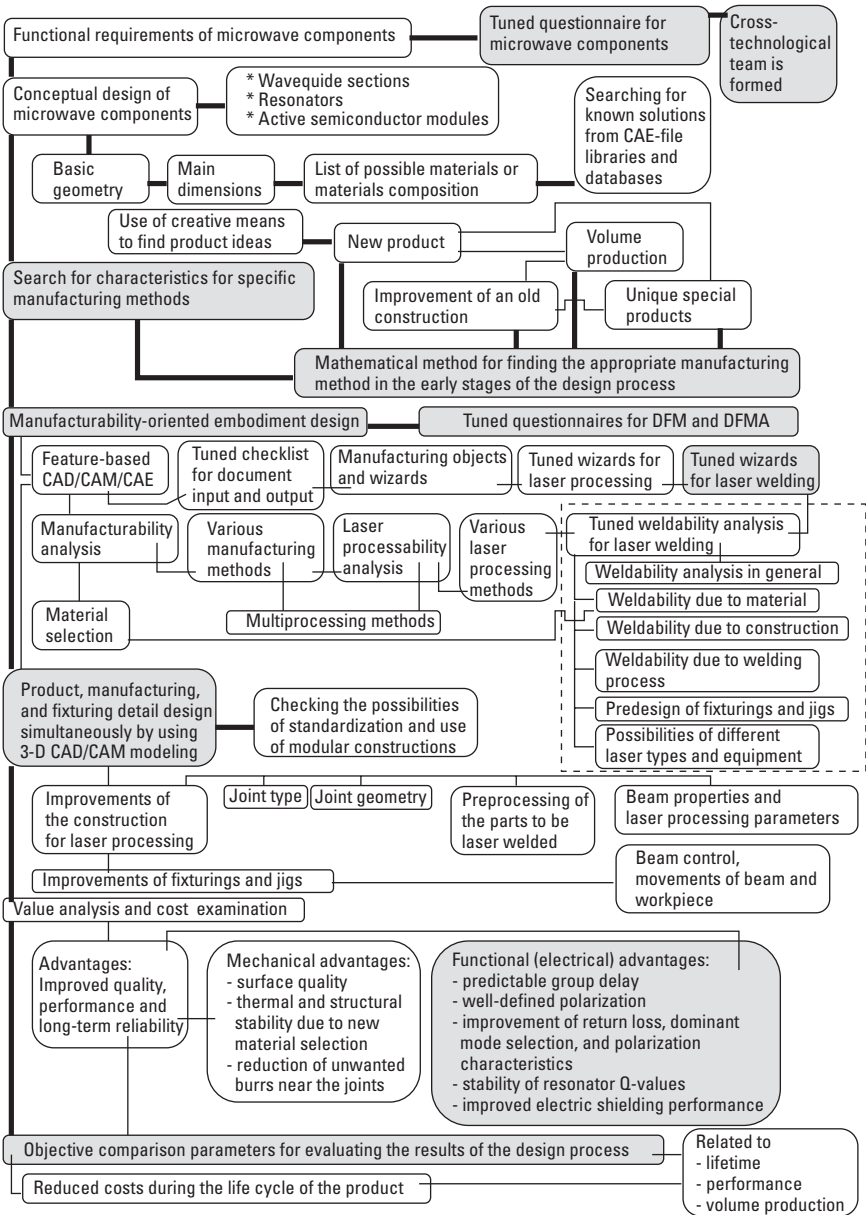

Figure 2.5 An overall flowchart of the tuned design methodology which includes manufacturability analysis and, furthermore as an application, weldability analysis, especially for laser welding (outlined area). The most important stages are marked with a gray background [31].

Secondly, the traditional embodiment design is tuned into the manufacturability-oriented embodiment design, which basically means that both feature based CAD/CAM/computer-aided engineering (CAE) programs and wizards are utilized. In this case, after recognizing that the product will be laser processed, the tuned wizards for laser processing are used.

Even though the likelihood of using laser processing is found, there is still space left for manufacturability analysis: Because laser can be used for several manufacturing processes, it is necessary to analyze whether it can be utilized in several stages or if some multiprocessing methods are needed.

Thirdly, one of the main stages of the suggested methodology also includes checking for possibilities of standardization and the use of modular constructions. It is relevant to notice that the same CAD geometry is used, not only for designing the product itself and the fixturings or jigs, but also for programming the beam control and workpiece movements during laser processing.

Fourth, the value analysis and cost examination are carried out. Both the mechanical and functional advantages are derived from the common advantages of laser processing. The subjective advantages, however, are not used directly for evaluation, rather, comparative parameters are calculated related, for example, to lifetime and performance of the product. The volume of production is also taken into account.

The weldability analysis consists of three stages: weldability due to material(s), weldability due to construction, and weldability due to process (different laser applications). If other laser processing methods are used, the processability due to construction is not needed, but otherwise the steps are alike.

References

- [1] Pahl, G., and W. Beitz, *Engineering Design, A Systematic Approach*, London, England: Springer-Verlag, 1996.
- [2] Oakley, M., *Design Management, a Handbook of Issues and Methods*, Oxford, England: Basil Blackwell Ltd, 1990.
- [3] Hansen, F., *Konstruktionssystematik*, Berlin, Germany: VEB-Verlag Technik, 1965.
- [4] Müller, J., *Arbeitsmethoden der Technikwissenschaften. Systematik, Heuristik, Kreativität*, Heidelberg, Germany: Springer-Verlag, 1990.
- [5] Roth, K., *Konstruieren mit Konstruktionskatalogen, Band 2; Kataloge*, Heidelberg, Germany: Springer-Verlag, 1994.

-
- [6] Rodenacker, W. G., *Methodisches Konstruieren*, Heidelberg, Germany: Springer-Verlag, 1976.
- [7] Hubka, V., *Theorie der Konstruktionsprozesse, Analyse der Konstruktionstätigkeit*, Heidelberg, Germany: Springer-Verlag, 1976.
- [8] Koller, R., *Konstruktionsmethode für den Maschinen-, Geräte- und Apparatebau*, Heidelberg, Germany: Springer-Verlag.
- [9] Cross, N., *Engineering Design Methods. Strategies for Product Design*, Chichester, England: John Wiley & Sons Ltd., 1994.
- [10] French, M., *Invention and Evolution, Design in Nature and Engineering*, Cambridge, England: Cambridge University Press, 1994.
- [11] Lanigan, M., *Engineers in Business, the Principles of Management and Product Design*, Wokingham, England: Addison-Wesley Publishing Company, 1992.
- [12] Glegg, G. L., *Design of Design*, Cambridge, England: Cambridge University Press, 1971.
- [13] Glegg, G. L., *The Selection of Design*, Cambridge, England: Cambridge University Press, 1972.
- [14] Nadler, G., *The Planning and Design Approach*, New York, NY: John Wiley & Sons, 1981.
- [15] Eppinger, S. D., et al., "Organising the Task in Complex Design Projects," *American Society of Mechanical Engineers, ASME, Design Engineering Division (Publication) DE*, Vol. 27, Sept. 16–19, 1990, pp. 39–46.
- [16] Eppinger, S. D., et al., "A Model-Based Method for Organising Tasks in Product Development," *Research in Engineering Design*, Vol. 6, No. 1, 1994, pp. 1–13.
- [17] Smith, R. P., and S. D. Eppinger, "Identifying Controlling Features of Engineering Design Iteration," *Management Science*, Vol. 43, No. 3, 1997, pp. 276–293.
- [18] Smith, R. P., and S. D. Eppinger, "Predictive Model of Sequential Iteration in Engineering Design," *Management Science*, Vol. 43, No. 8, 1997, pp. 1104–1120.
- [19] Eppinger, S. D., "Model-Based Approaches to Managing Concurrent Engineering," *Journal of Engineering Design*, Vol. 2, No. 4, 1991, pp. 283–290.
- [20] Eppinger, S. D., M. V. Nukala, and D. E. Whitney, "Generalised Models of Design Iteration Using Signal Flow Graphs," *Research in Engineering Design—Theory, Applications and Concurrent Engineering*, Vol. 9, No. 2, 1997, pp. 112–123.
- [21] Krishnan, V., S. D. Eppinger, and D. E. Whitney, "Model-Based Framework to Overlap Product Development Activities," *Management Science*, Vol. 43, No. 4, 1997, pp. 437–451.
- [22] Krishnan, V., S. D. Eppinger, and D. E. Whitney, "Iterative Overlapping: Accelerating Product Development By Preliminary Information Exchange," *American Society*

- of Mechanical Engineers, Design Engineering Division (Publication) DE*, Vol. 53, Sept. 19–22, 1993, pp. 223–231.
- [23] Eppinger, S. D., C. H. Fine, and K. T. Ulrich, “Interdisciplinary Product Design Education,” *IEEE Transactions on Engineering Management*, Vol. 37, No. 4, 1990, pp. 301–305.
- [24] Ishikawa, K., “Quality and Standardisation: Program for Economic Success,” *Quality Progress*, Vol. 17, No. 1, 1984, pp. 16–20.
- [25] Ishikawa, K., “How to Apply Companywide Quality Control in Foreign Countries,” *Quality Progress*, Vol. 22, No. 9, 1989, pp. 70–74.
- [26] VDI 2221, *VDI Guidelines. Systematic Approach to the Design of Technical Systems and Products*, Verein Deutscher Ingenieure, Aug. 1987.
- [27] Walker, D. J., B. K. J. Dagger, and R. Roy, *Creative Techniques in Product and Engineering Design—A Practical Workbook*, Cambridge, England: Woodhead Publishing Limited, 1991.
- [28] Eskelinen, H., “Suggestions for Finding Optimum Materials and Manufacturing Methods for Metallic Microwave Cavity Resonators,” *Proc. 13th European Frequency and Time Forum and 1999 IEEE International Frequency Control Symposium*, Besancon, France, Apr. 13–16, 1999, pp. 567–572.
- [29] Eskelinen, H., “Laser Processing—An Optimal Tool for Encapsulating Electronics,” *Proc. 7th Nordic Conference in Laser Processing of Materials (NOLAMP)*, LUT, Finland, Aug. 23–25, 1999, pp. 491–496.
- [30] Eskelinen, H., “Weldability Issues of Mechanical Subassemblies for Harsh Environment Electronics,” *Proc. 1st Int. Welding Conference on Efficient Welding and Industrial Applications (ICEWIA)*, LUT, Finland, Aug. 25–27, 1999, pp. 123–130.
- [31] Eskelinen, H., and Eskelinen, P., “Weldability Analysis Guides the Joining Process in Microwave Mechanics,” *Proc. 9th Int. Conference on the Joining of Materials (JOM, Institute for Joining of Materials)*, Helsinki, Finland, May 16–19, 1999, pp. 157–163.

3

Material Selection for Microwave Mechanics

3.1 Basic Guidelines for Microwave Designers

The introduction of composites and the increasing number of metallic alloys improve the probability of finding an optimum material for a specific mechanical subassembly included in an electronic product. Since the application of conducting mainly metallic and nonconducting materials is mostly dictated by the electrical performance, these two groups are dealt with separately.

Generally, in an electronic device, the electrical requirement for metals is focused on the conductivity, which may be stated as a function of frequency. This, in turn, often includes the skin effect. Copper, aluminum, brass, gold, and silver are considered good, whereas various steel alloys are traditionally accepted only in heavy duty applications. Naturally, the magnetic characteristics of Fe alloys are often utilized (magnets, low frequency shields). The conventional manufacturing methods are either milling or sheet metal assemblies. For primitive but rapid prototypes some die-cast metallic enclosures are also commercially available.

From an electronic engineer's point of view, copper and conventional steels are not favorable because of their density. Both have problems with corrosion as well. Aluminum is lightweight, but is easily oxidized. Gold and silver, being expensive materials, do not match well with volume production

but are needed (e.g., in connectors) quite frequently as a coating. They improve performance in hostile environments.

Newly introduced requirements for electromagnetic compatibility within the European Union (EU) effectively restrict the use of all-plastic enclosures or support structures. Particularly vulnerable are high speed digital devices (e.g., modern PCs) or telecommunication products (modems, mobile phones). Supplemented with a conductive coating, however, these and different carbon fiber-based composites become very attractive. Their density is relatively low and their appearance is pleasant. A 50- to 100- μm copper or aluminum layer is often quite adequate, but efficient sealing is not a straight forward process.

Technically, the more challenging application of nonmetallic materials is encountered in various insulating and transmission line structures as well as in numerous antennas. Here, the key parameters are the complex permittivity (often expressed as the dielectric constant $\epsilon = \epsilon' - j\epsilon''$) and material inhomogeneities. Unfortunately, these tend to be changed when aggressive manufacturing methods are used, such as high temperature molding or pressing.

For most transmission lines and antennas, the dielectric material should have constant, purely real permittivity and a minimum amount of holes, impurities, or defects in the crystal structure. Common, traditionally applied trademarks are Teflon[®] and Duroid[™], coming in various forms and having an ϵ between 2 and 10. The structural integrity of most RF-dielectrics is not well-defined. Drilling or milling, for example, tends to create excessive heat that partly melts the sample and thus spoils its critical dimensions or alters its electric characteristics. In microwave mechanics, the material selection process should take into account four main topics, which are:

1. The electrical performance of the device or system;
2. The mechanical performance (including manufacturability aspects);
3. Environmental requirements;
4. The cost effectiveness as a product.

In practice, the final decision will be a compromise based on the above factors. It is also necessary to make a specific analysis depending on the product type. The requirements, for example, for insulating and interface (plating) materials, connectors, feeding strips, enclosures, and other devices essentially differ from each other. From the mechanics point of view, it is insufficient to select the appropriate material type (e.g., stainless steel or

brass). The exact material identification should be established instead. This includes the alloy's chemical composition and mechanical pretreatments or posttreatments. In many microwave textbooks, a misleading impression about the superiority of the plating or coating of the base material is given to the reader. We must understand that plating itself never can replace the careful base-material alloy analysis even though the coating is properly selected. Following these guidelines, we pick the most important materials for microwave mechanics here and make some illustrative comparisons. We also present some useful material data for a practical manufacturing analysis.

3.2 Effects of the Product's Operating Frequency

There is still a lot of work to be done to enhance the mutual understanding between designers of microwave mechanics and of the respective electronics, when these two groups try to make a compromise of material selection. Two main questions should be taken into account:

1. What is the effect of the selected material on the electromagnetic losses?
2. How does the microwave penetration depth depend on the selected material and on the operating frequency?

3.2.1 Electromagnetic Losses

Most practical conducting or isolating materials, for example in waveguides or antennas, are not perfect but have electromagnetic losses. This is the case when the resistance ρ of an insulator (dielectric material) does not approach infinity. The electric field inside the material creates a current which yields further losses. A very efficient way to handle material losses is by combining permittivity ϵ_r and conductivity. For a sinusoidal plane wave in a medium with permittivity ϵ_r and conductivity σ we can write

$$\nabla \times \mathbf{H} = j\omega\epsilon\mathbf{E} \quad (3.1)$$

where $\epsilon = \epsilon' - j\epsilon''$ (the permittivity is divided into its real and imaginary parts) or

$$\epsilon = \epsilon_r \epsilon_0 - \frac{j\sigma}{\omega} \quad (3.2)$$

where

ϵ_r	= relative permittivity
ϵ_0	= permittivity of a vacuum = $8.854 \cdot 10^{-12}$ F/m
ω	= angular frequency (1/s)
σ	= conductivity (S/m)
H	= magnetic field intensity (A/m)
E	= electric field intensity (V/m)

A good conductor, something we are aiming at, for example with waveguide or resonator walls, has $\epsilon' > \epsilon''$.

3.2.2 Definition of the Penetration Depth

Table 3.1 shows values of relative permeability μ_r and relative conductivity σ_r for typical metals (compared to the conductivity of copper $\sigma = 5.82 \cdot 10^7$ and permeability of pure air or a vacuum).

The microwave penetration depth δ of a material is

$$\delta = \sqrt{\frac{2}{\omega \mu \sigma}} \quad (3.3)$$

Where

δ	= penetration depth (m)
ω	= angular frequency (1/s)

Table 3.1

Typical Electrical Parameters for Some Common Construction Metals

	Relative Conductivity	Relative Permeability
Material	σ_r	μ_r
Aluminum (soft)	0.61	1
Aluminum (hard)	0.4	1
Copper	1.00	1
Steel	0.02	500
μ -metal	0.10	1,000

From: [1].

- μ = the permeability of the medium (Vs/Am)
 σ = conductivity (S/m)

Table 3.2 shows values of penetration depth for copper, aluminum, steel, and the more exotic μ -metal (Ni77/Fe14/Cu 5/Mo 4) as a function of frequency. As an example we can calculate the expected difference between a (normal) aluminum microwave waveguide and a similar steel device at 15 GHz. We apply the penetration depth formula (3.3) to both and get first, for steel

$$\delta_{steel} = \sqrt{\frac{2}{2 \cdot \pi \cdot 15 \cdot 10^9 \cdot 4 \cdot \pi \cdot 10^{-7} \cdot 500 \cdot 0.02 \cdot 58.2 \cdot 10^6}} \text{ m}$$

which equals about $0.170 \mu\text{m}$. For aluminum,

$$\delta_{Al} = \sqrt{\frac{2}{2 \cdot \pi \cdot 15 \cdot 10^9 \cdot 4 \cdot \pi \cdot 10^{-7} \cdot 1.04 \cdot 58.2 \cdot 10^6}} \text{ m}$$

which equals about $852 \mu\text{m}$. Both values are certainly adequate for the typically very short (less than 500 mm) distances in a waveguide. Actually, steel

Table 3.2
Penetration Depth (in Millimeters) as a Function of Frequency for Different Metals

Frequency	Copper	Aluminum	Steel (430)	μ -metal
60 Hz	8.509	10.897	0.8500	0.3556
100 Hz	6.604	8.458	0.6500	0.2794
1 kHz	2.083	2.667	0.2000	0.0762
10 kHz	0.660	0.838	0.0750	–
100 kHz	0.203	0.279	0.0200	–
1 MHz	0.076	0.076	0.0075	–
10 MHz	0.020	0.025	0.0025	–
100 MHz	0.007	0.008	0.0020	–
1,000 MHz	0.002	0.003	0.0010	–

From: [2].

(430) is found to be theoretically better than the frequently used light alloy construction, but corrosion effects have been omitted of course.

Figure 3.1 shows the absorption loss in decibels for 1- and 4-mm plates made of steel, copper, and aluminum. We notice readily that, at high microwave frequencies especially, steel tends to be problematic due to its less favorable conductivity.

Note that the conductivity of various metals is subject to variation according to processing and alloy composition. As shown in Table 3.3, the values of relative conductivity (e.g., for steels) are from 3 to 15 and for aluminum alloys from 30 to 50 if we give value 100 to copper.

In practical engineering design, the most difficult work is probably to find the proper values for resistivity or conductivity for each metal alloy. It is

Absorption loss [dB]

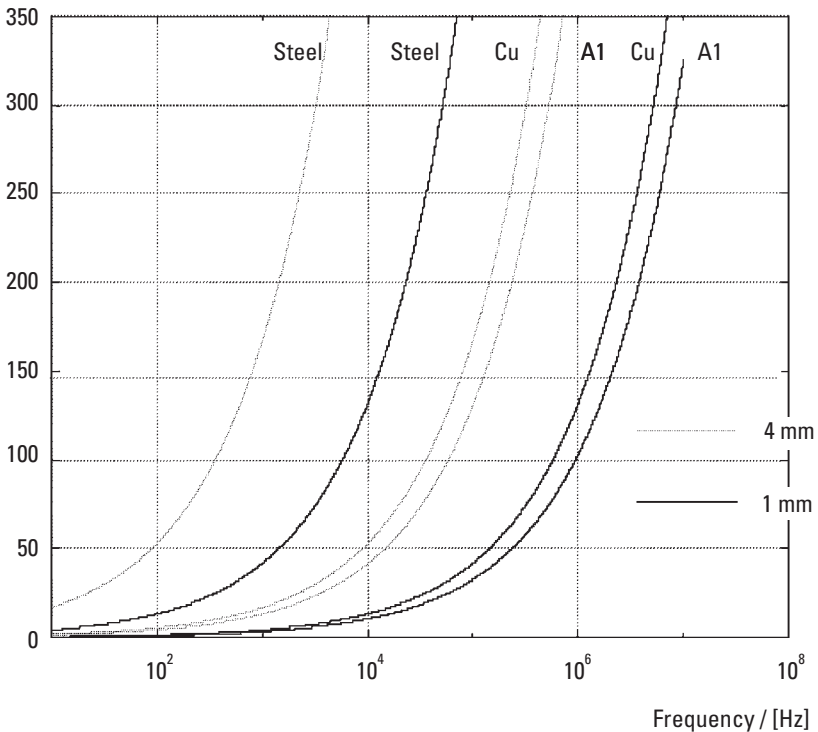

Figure 3.1 Absorption loss in different metals as a function of frequency. The dotted lines are for 4-mm material, and thick lines are for 1-mm material [2].

Table 3.3

Conductivity of Various Metals Subject to Variation According to Processing and Alloy Composition

Metal	Relative Conductivity in 20°C	Temperature Coefficient of Resistivity 1/°C
Aluminum (2S; pure)	59	0.0039
Aluminum (alloys):		
Soft-annealed	45–50	—
Heat-treated	30–45	—
Brass	28	0.002–0.007
Copper:		
Hard drawn	89.5	0.00382
Annealed	100	0.00393
Gold	65	0.0034
Iron:		
Cast	2–12	—
Nickel	12–16	0.006
Nickel silver (18%)	5.3	0.00014
Phosphor bronze	36	0.0018
Silver	106	0.0038
Steel	3–15	0.004–0.005
Tin	13	0.0042

From: [3–7].

obvious, as illustrated in Table 3.4, that serious mistakes may happen if the values of pure metals are used instead of the values of the specific alloy. It is also remarkable that the differences between the values of conductivity of each alloy (even if they can be classified in the same material group) are sometimes greater than 10%.

3.3 Effects of the Operating Environment

Generally, the mechanical subassemblies or individual parts may have three separate or combined tasks within an electronic device or system. Supporting structures are nearly always necessary due to the small size and insufficient integrity of electronic components. Their size ranges from huge 300-m

Table 3.4

Conductivities of Some Common Materials Suitable for Microwave Mechanics

Material	Resistance [Ωm]	Conductivity [S/m]	% IACS
AlMg3	4.844×10^{-8}	2.065×10^7	33.60–37.60
AlMgSi1 Cu	4.413×10^{-8}	2.265×10^7	37.60–40.50
Al (Pure)	2.826×10^{-8}	3.537×10^7	61.00
CuBe2	8.210×10^{-8}	1.218×10^7	21.00
Cu (Pure)	1.724×10^{-8}	5.799×10^7	100.00
Gold (Pure)	2.463×10^{-8}	4.061×10^7	70.00
AISI 304 L	6.897×10^{-8}	1.450×10^6	2.50
AISI 347	7.185×10^{-8}	1.392×10^6	2.40

From: [3–7].

(Note: Due to its superior conductivity, annealed copper is the international standard against which all other electrical conductors are compared. The International Electro-Technical Commission set the conductivity of copper at 100% in their International Annealed Copper Standard (IACS). This means that copper provides more current carrying capacity for a given diameter of wire than any other engineering metal. Today, copper conductors used in building wire actually have a conductivity rating of 100% or better, based on the IACS scale.)

antenna towers to submillimeter transistor mounts. Shocks, vibration, bending, and environmental loading are common problems. Efficient shielding, whether needed due to the general environment, (e.g., dust or moisture) or just to ensure proper operation under electromagnetic interference, is mostly left for mechanics. The most comprehensive applications are based on the physical dimensions and carefully designed structures. They produce the wanted electromagnetic behavior as typically found in various antennas, transmission lines, and transducers. These projects require the most extensive interaction between the mechanical and electronics designers.

A modern electronic device or circuit is amazingly sensitive regarding its operating environment, which may be harsh indeed. Key parameters are:

- Shock and vibration up to 1,000G and from 1 mHz to 100 kHz;
- Temperature between 2K and 1,000K;
- Humidity from 0% to 100% RH;
- Barometric pressure from 0 to 10 MPa;

- Chemical liquids or vapors with a pH between 2 and 13, heavily condensating;
- Electromagnetic radiation up to 2 MV/m, from DC to 300 GHz;
- Ionizing radiation (nuclear explosions, radiation in space).

In mechanical engineering, environmental degradation is typically classified into three main categories:

1. Corrosion and oxidation;
2. Wear;
3. Radiation damage.

To make a successful material comparison, we must specify exactly which type of corrosion, wear, or radiation loading the material is selected for. Corrosion of metallic materials may occur in a number of forms, which differ in their appearance:

- So-called general corrosion (rust on steel structures);
- Galvanic corrosion (with dissimilar metal pairs);
- Crevice corrosion (e.g., under rivets and bolts);
- Pitting corrosion (part of the surface becomes anodic compared with the other parts of the surface);
- Intergranular corrosion (e.g., near welded joints);
- Selective leaching (e.g., dezincification);
- Different combined actions of stress and corrosion.

All of these forms of corrosion are possible and some even probable in microwave applications either inside a specific component or in final assembly. It is typical that problems such as galvanic corrosion are tediously solved in component design but totally forgotten when the assembly process is outlined!

Many plastics do not suffer from the normal atmosphere but can be affected by sunlight. This damage is usually called aging. Some plastics, such as Teflon, can suffer from slight absorption of water. Others are sensitive to sticking smoke or dust particles. For environments and applications containing acids, alkalis, or other chemicals, there are a number of recommended

plastics. The real problem, however, is to find a material that is able to simultaneously withstand the operating conditions and provide the desired electromagnetic performance. There are four different types of wear mechanics to be identified:

1. Adhesive wear;
2. Abrasive wear;
3. Tribochemical wear;
4. Surface stress wear.

Engineers usually regard wear as an insubstantial factor for material selection in microwave mechanics. There are certain parts of the construction, however, that might be loaded by some of the wear mechanics as well (e.g., targetable antennas, connectors, rotary joints, or radar constructions).

A proper and careful mechanical design can substantially reduce the environmental stress accumulated on the electronics without breaking the project budget. The amplitude of vibrations can, and often must, be reduced in order to avoid fatigue cracking of printed circuit boards. Naturally, the enclosure must withstand the whole acceleration spectrum itself. Keeping the equipment temperature within reasonable limits is often carried out by mechanical parts such as radiating fins or insulating blocks. A tight, rigid, and suitably coated design limits temporary internal pressure variations and prevents the intrusion of, for example, highly corrosive industrial detergents. Finally, electromagnetic radiation can be attenuated by lossy materials which, however, must be selected according to suspected interference frequencies.

3.4 Metallic Components

The most common metallic materials in microwave mechanics are copper, copper alloys, phosphorus bronze, brass, stainless steel, aluminum and aluminum alloys, gold, and silver. There are hundreds of alloy variations available but only a few of them can satisfy the product's performance requirements. The main properties of metallic materials used for microwave components, in the order of importance for comparisons, are:

- Good electrical conductivity (minimize bulk resistivity, especially as frequencies go up);

- Machinability and ductility—easy and reasonable to shape, machine, or form with the required accuracy;
- Good stability and tensile strength to withstand mechanical influences;
- Good stress relaxation—resisting strain and elevated temperatures;
- Hardness—reducing the wear deterioration of contact metallization;
- Reasonable price.

3.4.1 Oxygen-Free Copper

It is important to compare different oxygen-free copper variations, because the electrical properties will change, especially depending on the required copper rate. Generally, oxygen-free copper is one of the most commonly used metals for electrical signals due to its excellent electrical and thermal conductivity. Oxygen-free copper is also used in windings and in applications where high magnetic fields are utilized. In general, we can assume that the higher the conductivity, the greater the rise in current flow. For connectors and cables, copper is usually applied as an alloy base metal or as an electrodeposited metal. Copper has a fairly good resistance against corrosion and chemical attacks, although the surface will turn black and form a green patina if exposed to sulphur compounds. Because Cu-OF, Cu-OF-OK, and Cu-OFE are not alloyed, their machinability is relatively poor. A rule of thumb is that machining speed should be high, feeding small, and cutting depth small. If an elevated softening temperature or higher creep strength is required, silver bearing copper grades based on Cu-OF-OK are used, such as CuAg0.1-OF alloy.

Typical applications are connectors and cable components. Copper is also used as a final coating or as an underplating material. Some important material data and a comparison between various oxygen-free copper compositions are presented in Table 3.5.

As Table 3.5 shows, it is necessary to know which Cu-OF composition is acceptable in quality-oriented microwave design and best for the application to be constructed.

3.4.2 Superconductor Oxygen-Free Copper

For superconductor technology, Outokumpu company in Finland has recently developed an extra pure Copper 99.999 in which the allowed oxygen content is limited to below 0.0002% and ferrite below 0.0004% [8]. The excellent electric and heat conducting properties of copper will increase

Table 3.5
Material Data for Cu-OF, Cu-OF-OK, Cu-OFE, and CuAg0.1-OF

Material	% Cu	% O maximum	Alloying	σ [MS/m]	ρ [n Ω m]	Thermal Conductivity [W/K m]
Cu-OF	99.95	0.05	–	58.4	17.6	395
Cu-OF-OK	99.99	0.0005	–	58.6	17.24	399
Cu-OFE	99.995	0.0005	–	58.6	17.02	399
CuAg.0.1-OF	99.98 Cu+Ag	0.0010	Ag 0.1	57.7	17.33	395

From: [6].

due to the extremely small oxygen and ferrite rates. On the other hand, it is not possible to reach those mechanical properties of alloyed coppers. This will cause several extra manufacturing stages when using Cu 99.999 in practice. Of course the price is quite high for the moment due to the exact purifying process. This material is in industrial use, for example in the windings of the magnets that are going to be used to control the next particle accelerator at CERN laboratories. It is obvious that this success with Cu 99.9999 will encourage people to push the quality in microwave components further as well [6].

3.4.3 Beryllium Copper Alloy

Beryllium copper has a good electrical and thermal conductivity too. It can be used without additional plating, because the corrosion resistance is good, except to ammonia and strong acids and bases. Strong bases and an adverse environment can even cause stress corrosion cracking. The good thermal conductivity and very high tensile strength allow it to be exposed to high temperatures without a risk of melting or deterioration of other factors.

CuBe2 is an alternative to the pure or even silver-bearing copper, as it has a better corrosion resistance. Another difference between copper and beryllium copper is the lower electrical and thermal conductivity of CuBe2. Its machinability is better than that of copper but not as good as that of phosphorus bronze. In addition, beryllium copper can be heat treated and has excellent long-term spring characteristics. It is significantly more expensive than copper, however. One serious disadvantage is the vaporizing propensity

of beryllium at high temperatures. This makes it difficult to apply any of those welding processes that are based on reaching the melting point of the material. In some connector applications, hardened CuBe2 alloy is used which makes it necessary to increase pressing forces (for example, if USW process is applied for joining the center pins of the connectors) [9].

Beryllium copper is used for many connector components such as contact sockets (electrical contacts), spring fingers, and subminiature connector (SMA) bodies.

Some useful material data for CuBe2 is presented in Table 3.6. For further mechanical assembly applications, we will also present here some practical mechanical material data for CuBe2.

It is important to understand the differences between the various alternative CuBe2 alloys depending on the chemical composition or the used heat-treatment methods of the specific alloy. There are more than 75 CuBe2 variants, all of which can be classified and standardized under the same identification (only the beryllium content is set to be from 1.8 to 2.0%). The CuBe2 alloy that is used, for example, for center pins of SMA connectors is probably the most common in microwave mechanics. Its composition is presented in Table 3.7. The changes in the amount of Be, Co, Ni, Fe, and Pb, in particular, can lead to problems when trying to control either the welding or soldering parameters [10].

3.4.4 Phosphorus Bronze

This alloy is a particularly soft metal, which only gets its strength from cold working, such as stamping and bending. CuSn6 is usually selected if the performance requirements of the end product are not critical and especially if a degree of cost-effectiveness is desired. This copper alloy is used for products such as contact sockets, resilient contacts, and outer conductors.

Table 3.6
Material Data for CuBe2

Melting Temperature [°C]	σ [MS/m]	ρ [nΩm]	Tensile Strength [MPa]	Modulus of Elasticity [MPa]	Hardness [HV]
900	37.9	28	1,400	130,000	340

From: [10].

Table 3.7
Chemical Composition of CuBe2 (ASTM B-197 QQ-C-530)

Component	Weight (%)
Be	1.8 to 2
Co+Ni	Minimum 0.2
Co+Ni+Fe	Maximum 0.6
Pb	0.2 to 0.6
Cu	97.5
Standard	ASTM B-197 QQ-C-530

From: [11].

3.4.5 Brass

CuZn39Pb3 is a soft and very easily machined material. Unlike many copper alloyed materials brass does not produce long chips during machining and therefore the surface quality is much better. Just like beryllium copper, brass conducts heat and electricity well. Furthermore, the resistance against industrial, marine, and rural atmospheres and various oils is good. Typically, CuZn39Pb3 is gold or silver plated to improve corrosion resistance. This material is used for connector bodies, housings, outer conductors, and contact pins. Material properties of CuSn6 and CuZn39Pb3 are compared in Table 3.8(a, b).

3.4.6 Stainless Steels

Steel and stainless steels are some of the most frequently used metals in the mechanical industry. For microwave applications the most often used alloy is AISI 303. Stainless steel, as such, is mostly used in the connector industry for applications requiring hardness, for example, in outer conductors but not so much for contact parts. AISI 303 has a relatively low electrical conductivity and comparatively poor machinability. On the other hand, its high stability, high melting temperature, and fair corrosion resistance are excellent characteristics, especially when the material is used for the outer component of a product (e.g., as housings). This steel has good general corrosion resistance but AISI 304 L, AISI 347, or AISI 321 are much better against intergranular corrosion. Usually, stainless steel is only used as base material for bodies and outer contacts. Probably the most important aspect when comparing

Table 3.8 (a)

Material Data for CuSn6 and CuZn39Pb3: Mechanical and Electrical Properties

Material	Melting Temperature (°C)	σ (MS/m)	ρ (nΩm)	Tensile Strength (MPa)	Modulus of Elasticity (MPa)
CuSn6	950	25.85	39	88	112,000
CuZn39Pb3	890	48.3	22	400	96,000

Table 3.8 (b)

Material Data for CuSn6 and CuZn39Pb3: Chemical Composition

Material	% Cu	% Fe maximum	% P maximum	% Pb	% Sn	% Zn
CuSn6	94	0.1	0.4	0.05 (maximum)	6	0.3 (maximum)
CuZn39Pb3	58	0.35	–	3	–	39

From: [3–7].

stainless steels is their chemical composition. The practical area of utilization (here, corrosion resistance properties), machinability, and weldability depend mostly on the carbon content and the applied alloying of the steel. This comparison is presented in Table 3.9.

Typically, the mechanical properties of stainless steels are similar to each other and the differences can be found in corrosion resistance and manufacturability. If exact values are needed, however, the easiest way is to refer to the identification number of each steel type (see Table 3.10).

Table 3.9

Chemical Composition of the Most Frequently Used Stainless Steels in Microwave Mechanics

Material	Identification	% C	% Cr	% Ni	Other Alloying
AISI 303	X12 CrNiS 18 8	< 0.15	18	8	S
AISI 304L	X5 CrNi 18 9	< 0,07	18	9	
AISI 347	X10 CrNiNb 18 10	< 0.10	18	10.5	Nb,Ta
AISI 321	X 10 CrNiTi 18 9	< 0.10	18	10.5	Ti

From: [3–7].

Table 3.10
Identification Numbers for Some Stainless Steels

Material	Identification Number
AISI 303	1.4305
AISI 304L	1.4301
AISI 347	1.4550
AISI 321	1.4541

3.4.7 Aluminum Alloys

Aluminum is rarely used in its elementary form but rather as an alloy. One of the most frequently needed alloys in microwave components so far has been AlMgSi1, which is easily machined. In addition to this, most connector bodies, for example, made of AlMgSi1 do not require any plating. For welded and sheet metal applications, especially in antenna designs, AlMg3 is also widely used nowadays. It is obvious that the reason for selecting AlMgSi1 is its good soldering property (at high temperatures this alloy can not be used). On the other hand, AlMg3 is a common sheet metal alloy and it is also relatively suitable for cutting and even welding. Manufacturability characteristics of various aluminum alloys differ a lot, and the final material selection should be made carefully together with the material manufacturer. These alloys are used for many types of housings and bodies.

Mechanical microwave designs made of aluminum alloys are not often critical regarding fatigue strength values or heat-treatment guidelines. However, in recent antenna applications, for example, the antenna body is made of sheet aluminum and the radiating elements are welded to that body. Here the designer should be aware of the possibilities of utilizing different heat treatments. Some preliminary strength calculations are also necessary. For these purposes, abbreviated material data and appropriate information about heat treatment effects on AlMgSi1 and AlMg3 are presented in Table 3.11. Many microwave textbooks present only average values of tensile strength for aluminum alloys. Table 3.11 shows clearly that if a constructional function (for example a load-carrying element of an antenna) is included, rough average values should never be used!

Even more interesting for practical manufacturability analysis is the fact that some aluminum alloys can be delivered either for mechanical working or also for casting. Alloys for casting are shown with the code G before

Table 3.11

The Effects of Heat Treatments on the Fatigue Strength of Aluminum Alloys

Material	Heat Treatment (Temper)	Endurance Limit for Reversed Bending Stress [MPa]	Number of Cycles
AlMgSi1	None	75	5×10^7
AlMgSi1 T5	Heat treatment with natural aging	80	5×10^7
AlMgSi1 T6	Heat treatment with artificial aging	115	5×10^7
AlMg3	None	120	5×10^7
AlMg3 H18	Strain hardened and stabilized	140	5×10^7

the material identification (e.g., G-AlMg3). To assist in finding more detailed information aluminum alloys also have a corresponding material identification number as shown in Table 3.12.

A special commercial set of aluminum alloys, known worldwide as ALUMEC,[®] includes four main alternatives: ALUMEC 79, ALUMEC 89, ALUMEC 99, and ALUMEC HT. The basic difference between these alloys is illustrated in Table 3.13.

In some applications, the external environmental loading of the product after delivery is almost insignificant. The critical loading consists of forces and stresses during the manufacturing process. This means that high-strength materials should be selected to ensure the required dimensional accuracy and surface quality. If lightweight materials are needed ALUMEC is

Table 3.12

Identification Numbers for Aluminum Alloys

Aluminum Alloy	Identification Number
AlMg3	5754
AlMgSi1	6082
G-AlMg3	5.754

Table 3.13
Comparison Between Various ALUMEC Compositions

Material Identification	Typical Properties
ALUMEC 79	Offers high strength and better homogeneity of thick plates (e.g., than aluminum 7075-T651).
ALUMEC 89	Compared to ALUMEC 79, offers higher strength, improved wear resistance, and better machinability with better polishability.
ALUMEC 99	Offers significantly improved corrosion resistance. Strength characteristics are between ALUMEC 79 and 89.
ALUMEC HT	Retains its strength in elevated temperatures.

From: [3–7, 9].

a good choice. It is a high strength Cu-alloyed aluminum in the form of hot rolled, heat-treated plate. It undergoes a special cold stretching operation for maximum stress relieving. Typical tensile strength values, which for most practical purposes can be compared to compression strength values, are presented in Table 3.14. Excellent machinability properties ensure high cutting speeds, reduced machining time, lower tooling costs, and therefore faster deliveries. Typical cutting data is shown in Table 3.15 for milling. These values should be adapted, however, to existing local conditions. Delivery condition is typically in a form of heat-treated plate from 164 to 168 Brinell, but if needed, ALUMEC can be hard anodized for higher wear resistance, giving a surface hardness equivalent to about 65 HRC (hardness according to the Rockwell test) in steel.

3.4.8 Invar

Invar is nickel-iron alloy with a rate of thermal expansion approximately one-tenth that of carbon steel at temperatures up to 204°C. Invar is an alloy with the lowest thermal expansion coefficient of any of the iron-nickel alloys. Its coefficient of expansion is about 1.7 to 2 ($\times 10^{-6} \text{ K}^{-1}$). It is used for applications where dimensional changes due to temperature variation must be minimized. Invar is also used in conjunction with high-expansion alloys in applications where a motion is desired when the temperature changes, such as in bimetallic thermostats and in rod and tube assemblies for temperature regulators. Invar may be worked using any conventional metal-working

Table 3.14
Tensile Strength (ALUMEC 99)

Plate Thickness [mm]	Tensile Strength [MPa]	Yield Point [MPa]
50	575	525
100	570	520
150	560	510
200	560	510

From: [12].

Table 3.15
Milling Data (ALUMEC 99)

Parameter	Rough Milling (Carbide)	Fine Milling (Carbide)	Fine Milling (PCD*)	Milling High (HSS)
Cutting speed v_c (m/min)	600–1,000	1,000–3,000	800–4,000	250–400
Feed f_z (mm/tooth)	0.2–0.6	0.1–0.2	0.05–0.2	Up to 0.4
Depth of cut a_p (mm)	2–8	Up to 2	Up to 2	Up to 8

*PCD = Polycrystallized diamond

From: [12].

method. Annealed material, however, is desirable for deep drawing, hydro-forming, or spinning. Invar may be chemically etched as well. Invar can be heat treated using various annealing methods. Heating and cooling rates, however, should be controlled to prevent damage to the parts (cracking or warping). Conventional welding methods can be used with Invar, but Invar filler rod is recommended for those welds requiring filler rod. Invar is used in several high-temperature applications in radio and electronic devices, in aircraft controls, and also for fabrication of high-stability cavities and critical resonators. It is also used for balance wheels for clocks and watches, bimetal strip, glass-to-metal seals, and structural components in laser systems. Its electrical resistance is about 75 to 85 $\mu\Omega\text{m}$, modulus of elasticity about 140

to 150 GPa, and tensile strength about 450 to 590 MPa. In addition to the name Invar, several brand names are often used, such as Invar 36, Nilo-alloy 36, Nilvar NS 36, Permalloy D, Radio metal 36, and Vacodil 36 [3–5].

3.5 Use of Plastics

The use of plastics for microwave applications has increased rapidly. Several types of plastics have been produced widely for insulating elements, cables, sealing components, and housings, or as plating material. Reinforced plastics are used as radomes in antenna applications. The range of different plastic types is so wide that it is reasonable to focus here on the most useful main alternatives such as polyethylene (PE), polytetrafluoroethylene (PTFE), fluoroethylenepropylene, and polyether-etherketone (PEEK).

3.5.1 PTFE

PTFE is a fluorine plastic with an excellent resistance to most chemicals. It can, however, be affected by alkalines such as nitrous acids. PTFE is highly thermostable (from -200° to $+250^{\circ}\text{C}$) and has a low flammability. The melting phase starts at about $+327^{\circ}\text{C}$ and the material turns into a jellylike substance. PTFE is often chemically etched to facilitate bonding with adhesives.

In addition, it is an antistatic and a very antiadhesive plastic due to its extremely low surface resistivity coefficient. The excellent electrical and dielectric properties, independent of frequency and temperature range, are matched by a low modulus of elasticity, which makes it applicable as a connector insulator. PTFE cannot be treated by the thermoplastic methods of injection molding or extrusion because of its high viscosity. Instead, it is usually die-pressed in a cold state. It is one of the most well-known fluorine plastics used for technical applications in the industry. The most serious disadvantage is the difficulty of finding reliable joining methods or an appropriate adhesive paste for PTFE elements. Typical applications of PTFE include many kinds of insulators, gaskets, packaging materials, and antiadhesive coatings.

3.5.2 PE

The density of PE is low. It has good electrical and dielectric properties, which makes this plastic material suitable for microwave and RF applications. Its high water diffusion resistance, low water absorption, and high resistance to chemicals (except oxidative acids) also provide the possibility of

applying this material in adverse environments without deteriorating mechanical or electrical properties. Machinability is rather good. The worst disadvantage of PE is its low melting temperature. It burns like wax. During burning, however, it will not emit any toxic chlorine or fluorine gases.

Some typical applications of polyethylene are turned insulators, wire and cable insulation, cable jacket material, corrugated cables, and packaging.

3.5.3 Other Fluorine Plastics

The most significant differences between the common fluorine plastics concern their modulus of elasticity and lowest practical temperature. Perfluoropolymer (PFA) has a lower elasticity (higher hardness and form stability) and a higher temperature limit than both PTFE and fluoroethylenepropylene (FEP).

Both FEP and PFA can be thermoplastically worked by extrusion and injection molding. Remolding and welding are also possible. Because of high flame resistance, the remolding process is only possible at high temperatures.

Like PTFE, PFA also has a good thermostability from -200° to $+250^{\circ}\text{C}$ and a small electrical conductivity. PFA has a high abrasion resistance and a good antiadhesive performance. PFA has an excellent resistance to most chemicals. The resistance to severe meteorological and atmospheric conditions is considered to be good. Typical applications with PFA include insulators, wire, and cable jackets.

3.5.4 PEEK

PEEK is a heavy-duty plastic with a partially crystalline structure. It has a high tensile strength, excellent form stability at high temperatures, and a melting temperature of 334°C . The ability to resist chemicals, except for concentrated sulphuric acid, is comparable to PTFE, PFA, and FEP. In addition to this, its high abrasion resistance and strength to withstand radiation, hydrolysis, and moisture in any form enable this plastic to perform superbly in extreme conditions. The crystalline structure also allows thermal remolding of PEEK.

Its low electrical conductivity, very high strength, and the fact that its weight is 30% of that of aluminum (when used for strengthening other materials) also make it suitable as an insulating material for cables exposed to high doses of radiation. PEEK is flame retardant and does not emit fumes or smoke, which is important for certain cable applications. Some well-known applications with PEEK are radiation-resistant wire insulations, wire coatings, and general insulators.

3.5.5 Polyphenylene Oxide

Polyphenylene oxide (PPO) is an amorphous thermoplastic with an excellent resistance to hydrolysis, various detergents, acids, and bases at high temperatures. On the other hand, PPO is not resistant to ketone or chlorinated and aromatic hydrocarbons, which dissolve the material.

It has an excellent thermal conductivity and a negligible loss factor. It is barely influenced by external temperature, frequency, or moisture. As with PEEK, PPO has a high temperature stability, but at a lower temperature than PEEK. Compared to polycarbonate (PC), however, it has the same inflexible and tough structure combined with high dimensional stability at high temperatures. Additionally, its low water absorption enables PPO to be used outdoors. Typical applications made of PPO are thermal and electrical insulator parts switch housings, and covers.

3.5.6 Reinforced Plastics

Some specific microwave devices call for lightweight but sturdy covers or shields. Typical applications are patch antenna constructions where the radiating elements must be placed inside a radome to prevent snow, ice, and water, for example, from damaging the mast-mounted antenna element. Similar requirements are typical in many military radar applications. Fiberglass and carbon-reinforced plastics are the most common materials used for these purposes. The main advantage of reinforced plastics is that the strength and elasticity properties can be established separately in each direction of the material. By selecting an appropriate combination of the composite, the material properties can be optimized as required. If not properly protected, many reinforced covers do, however, suffer from aging of the material due to UV radiation. Table 3.16 is a comparison of the most commonly used plastics in microwave applications.

3.6 Utilization of Ceramic Materials and Powder Metallurgy

Powder metallurgy has become a competitive process with casting, forging, and machining especially when relatively complex geometries are manufactured and if highly specific material properties are required (e.g., high flame resistance, high wear resistance, chemical filtering properties, smart material properties, magnetic properties). In electronics, we all know the common powder-metallurgy applications, such as diode heat sinks, relays, and magnets, in which several metal powders are utilized together with ceramics. One

Table 3.16

Comparison Between the Properties of the Most Commonly Used Plastics in Microwave Mechanics

Property	PE	PTFE	PFA	FEP	PEEK	PPO
Maximum temperature °C	70	250	250	-100	-70	-30
Minimum temperature °C	-50	-200	-200	-2,000	-250	-140
Melting temperature °C	127	327	305	Not analyzed	334	230
Dielectric constant at 1 MHz	2.34	2.1	2.1	2.1	Not analyzed	2.6
Electrical resistivity Ωm	1×10^{17}	1×10^{18}	1×10^{15}	2×10^{18}	5×10^{16}	1×10^{16}
Tensile strength MPa	26.5	27	27.5	20.6	92	60
Modulus of elasticity MPa	1,050	410	Not analyzed	350	3,650	2,500
Water resistance	Excellent	Excellent	Good	Excellent	Poor	Good
Flammability	Good	Very poor	Very poor	Very poor	Very poor	Not analyzed
Chemical resistance	Good	Excellent	Excellent	Excellent	Excellent	Not analyzed
Relative price *	1	15	23	20	45	4
UV-radiation resistance	Poor	Excellent	Excellent	Excellent	Good	Poor

*Relative price for polyethylene PE-HD is estimated to ratio 1
From: [6, 7, 10, 12, 13].

modern application area is manufacturing superconductors, where ceramic superconducting materials (grain size $0.5 \mu\text{m}$) are packed into silver tubes. In general, powder metallurgy is a manufacturing process that requires:

1. A careful selection of the powder composition (either metallic, ceramic, or fixed);
2. The choice of the most suitable processing alternative;
3. The choice of technically effective finishing operations;
4. A full design for the assembly-manufactured components.

The most serious disadvantages of powder metallurgy are as follows:

1. Molds and tooling systems are relatively expensive.
2. Ceramic compositions, in particular, can suffer from low impact toughness.
3. The manufacturing process of the powder itself can be complicated.
4. The joining of powder components requires specific designs.
5. The finishing process requires special tooling and arrangements.

The practical powder-metallurgical process consists of five main stages. It is useless to try to separate too explicitly the manufacturing stages from the material selection stages because some of the properties are determined during the last manufacturing stages. The main stages are as follows:

1. Powder production;
2. Blending;
3. Compaction;
4. Sintering;
5. Finishing operations.

For powder production there are several traditional processes available such as atomization, oxygen reduction process, electrolytic deposition, mechanical powderization, and mechanical powder alloying. Several types of high-pressure and warm pressing technologies can also be used.

During the blending stage, some lubricants can be added to the powder to help both the pressing and sintering stages. A properly made blending is also necessary within fixed powders, which have different sizes and densities of material particles.

Compaction is the stage in which the blended powder is pressed into the required shape of the component or device. Cold isostatic pressing, hot isostatic pressing, or injection molding can be utilized. During this stage, the most important process parameters are the compacting pressure (force/area unit in specific direction) and desired density level of the powder.

During the sintering process, the final fusion between the material particles takes place. The most important process parameters (sintering temperature and time) depend on the powder composition.

Specific finishing operations for powder-metallurgically manufactured components are sizing with high-pressure compaction, impact forging,

impregnating with a fluid, and infiltration. For metallic materials, it is also possible to apply some heat treatments. It is relatively difficult to choose an effective finishing process for the metallic or ceramic powder part. Grinding with diamond wheels, ultrasonic machining, and electrical-discharge machining may be feasible. Depending even more on the composition of the material, laser-beam machining can be utilized in some cases.

The design steps of a powder component can follow the general rules written for common casting processes. The dimensional uncertainty of powder metallurgy with conventional processes is not better than 0.05 mm, but will be significantly improved if any of the previously mentioned finishing technologies could be applied [14–16].

3.6.1 Powder-Metallurgically Manufactured Materials for Microwave Mechanics

Composite ceramics are designed to have a tailored combination of particulate dielectric properties and electrical resistivity for microwave applications.

Steatite and alumina ceramic insulators are designed to be used in all types of communication devices operating at a very high voltage and high frequency. They are suitable for mobile communication devices, outdoor broadcasting vans, microwave antennas, and super power transmitters. These materials can be supplied in many shapes and sizes. The material properties of the selected ceramics should usually provide the combination of microwave energy absorption and thermal conductivity required by this demanding environment. In addition to this, we must be able to achieve the precise dimensional control of the target component. Typically, the most important material characteristics for a ceramic microwave element are:

- Microwave absorption characteristics;
- Thermal conductivity;
- Consistency of properties;
- Reliability;
- Precision-machining capability.

Depending on the application, it is common that the following requirements should also be met:

- Tailored dielectric properties;
- Required electrical resistivity;
- High dielectric strength.

The selection of possible ceramics can be divided into two main groups: (1) basic powder materials, and (2) powder compositions.

Basic powder materials are:

- Aluminum nitride—AlN;
- Aluminum oxide—Al₂O₃;
- Silicon carbide—SiC;
- Boron carbide —B₄C.

Key compositions are:

- Magnesium oxide–silicon carbide;
- Aluminum oxide–silicon carbide;
- Aluminum nitride–silicon carbide;
- Beryllium oxide–silicon carbide;
- Magnesia-silicon carbide—MgO-SiC.

To tailor the properties, however, there are several commercial composition trademarks of each composition type that have specialized material properties. The main properties of some aluminum and magnesium oxide compositions are presented in Table 3.17, and a typical comparison of several tailored compositions is presented in Table 3.18.

Many conventional materials fail in semiconductor processing environments where the next generation of fine line geometry microchips are being fabricated. New material properties which will be critical are:

- High purity;
- No particle generation;
- Corrosion resistance;
- Tailored thermal and electrical properties.

These properties address new quality requirements in the manufacturing process of the powder itself and, of course, after that, to the practical manufacturing control of the final microwave component.

Table 3.17
Properties of Some Aluminum and Magnesium Oxide Compositions

Composition	Al ₂ O ₃ + 60% SiC	MgO + 2% SiC	MgO + 5% SiC	AlN + 40% SiC	AlN + 40% SiC
Tailoring allowed	Yes	Yes	Yes	Yes	Yes
Processing route	Hot pressing	Hot pressing	Hot pressing	Hot pressing	Hot pressing
Density (kg/m ³)	3,360	3,500	3,480	3,190	3,190
Thermal conductivity (W/mK)		30	30	30	53
ϵ_r (1 GHz)				22	30
ϵ_r (8 GHz)	130	11.2	12.8	15	22
ϵ_r (10 GHz)	83	11.1	12.7	15	21
ϵ_r (12 GHz)	69	10.9	12.6		
Tan(δ) (1.0 GHz)				0.11	0.11
Tan(δ) (8.0 GHz)	0.40	0.02	0.03	0.30	0.30
Tan(δ) (10.0 GHz)	0.57	0.02	0.03	0.28	0.28
Tan(δ) (12.0 GHz)	0.53	0.02	0.03		
Thermal expansion coefficient (RT – 1,000°C) $\times 10^{-6}/^\circ\text{C}$		15.4	14.8	5.1	5.1
Flexural strength (MPa)		200	200	300	300
Applications	Slot mode, absorbers	Absorbers, buttons	Absorbers, buttons	Replacement for Ceralloy 2,710, BeO-SiC, terminations, sever wedges, load pellets, absorbers	Replacement for Ceralloy 2,710 BeO-SiC, terminations, sever wedges, load pellets, absorbers

From: [6, 7, 10, 12, 13].

Table 3.18
Comparison Between Some Commercial AlN and BeO Compositions

Composition	AlN composite	AlN composite	BeO + 40% SiC	AlN	BeO (99.5%)
Tailoring allowed	Yes	Yes	Yes	N/A	
Processing route	Hot pressing	Hot pressing	Hot pressing	Hot pressing	
Density (kg/m ³)	2,990	2,990	3,020	3,260	
Outgassing	No	No	No	No	No
Thermal conductivity (W/mK)	85	95–105	130	160–200	250
ϵ_r (1 GHz)	28	45	33	8 to 9	7.0
ϵ_r (8 GHz)	18	30	24		
ϵ_r (10 GHz)	18	28	23		
ϵ_r (12 GHz)					
Tan(δ) (1 GHz)	0.20	0.15	0.05	0.0005–0.001	
Tan(δ) (8 GHz)	0.20	0.30	0.25		
Tan(δ) (10 GHz)	0.20	0.30	0.25		
Tan(δ) (12 GHz)					
Thermal expansion coefficient (RT – 1,000°C) x 10 ⁻⁶ /°C	5.0	5.0	7.0	4.3	8.3
Flexural strength (MPa)				260	175
Applications	Replacement for Ceralloy 2,710 BeO-SiC, terminations, sever wedges, load pellets, absorbers	Replacement for Ceralloy 2,710 BeO-SiC, terminations, sever wedges, load pellets, absorbers	Terminations, sever wedges, load pellets, absorbers	Replacement for 99.5 BeO, collector rods, helix support rods, windows	Collector rods, helix support rods, windows

Table 3.18 (continued)

Composition	AlN composite	AlN composite	BeO + 40% SiC	AlN	BeO (99.5%)
Key features	Higher thermal conductivity than Ceralloy 2,710 Temperatures 200°C, close match in electrical properties	Higher thermal conductivity than Ceralloy 2,710 Temperatures 150°C, close match in electrical properties	Former industry standard for terminations, for example	Higher thermal conductivity than BeO temps 100°C	Higher thermal conductivity at room temperature
Grade	Ceralloy 137 CA	Ceralloy 137 CB	Ceralloy 2,710	Ceralloy 1,370°C	

From: [6, 7, 10, 12, 13].

For more than 20 years, the microwave tube industry has been using BeO-SiC lossy ceramic composite materials for their components. Due to the toxicity of BeO during the production process, however, alternative material compositions should be found. In many cases the solution could be based on compositions based on AlN.

It is also important to notice that the manufacturing process has an extensive effect on the properties of a ceramic composition. An illustrative example is presented in Table 3.19 for hot pressed and sintered aluminum nitride compositions.

3.6.2 Application Areas of Ceramic Materials in Microwave Mechanics

Samarium cobalt devices offer energy levels among the highest available in commercial magnets (compared to the traditional Niobium powder magnets). Combined with high temperature stability and high corrosion resistance, these ceramic magnets can be the premium choice for microwave radar and navigational systems. Samarium cobalt magnets are widely used in the communication and defense industries. There are two common compositions used for industrial applications:

1. Samarium cobalt—SmCo₅;

Table 3.19
Comparison Between Hot Pressed and Sintered Aluminum Nitride Compositions

Process	Hot Pressed	Sintered
Density (kg/m ³)	3,260	3,300
Density (% theoretical)	>99.8	>98.0
Color	Gray	Gray
Flexural strength (MPa) RT	330	260
Weibull modulus	10	10
Elastic modulus (GPa)	320	315
Poisson's ratio	0.22	0.23
Hardness HV (0.3) (kg/mm ²)	1,100	1,110
Fracture toughness (MPa m ^{1/2})	2.5	3.1
Thermal expansion coefficient (RT – 1,000°C) × 10 ⁻⁶ /°C	4.9	6.2
Thermal conductivity (W/mK) 25°C	80	170–190
Thermal shock parameter (°C)	180	
Electrical resistivity (Ωm)	10 ¹²	10 ¹³
Dielectric constant	8.9	8.7
Applications	Electronic components, semiconductor components, windows, heaters, chucks, clamp rings, gas distribution plates	Microwave components, collector rods, helix support rods, windows, electronic components, semiconductor components, chucks, heaters
Key features	Thermal conductivity, electrical insulator	High thermal conductivity

From: [6, 7, 10, 12, 13].

2. Samarium cobalt—Sm₂Co₁₇.

Like other powder compositions, samarium cobalt has several tailoring possibilities. One comparison is presented in Table 3.20 (note the choice of magnetic alignments).

Table 3.20
Comparison Between Two Different $\text{Sm}_2\text{Co}_{17}$ Compositions

Magnetic Alignment (to Compaction Axis)	Remarks	Perpendicular	Parallel
Density (kg/m^3)		8,300	8,300
Resistivity ($\text{M}\Omega\text{m}$)		0.5	0.5
Thermal conductivity ($\text{cal/cm/sec/}^\circ\text{C}$)		0.025	0.025
Curie temperature ($^\circ\text{C}$)		800	800
Br (kG)	Remanence of mag- netic flux density	9.0–9.6	8.0–9.0
Hc (kOe)	Magnetic field strength	8.4–9.6	7.6–8.6
Hci (kOe)	Magnetic field strength	18	18
BHmax (M GOe)	Magnetic energy density	20–23	16–20
RTC ($\%/^\circ\text{C}$)	Relative tempera- ture coefficient	-0.030	-0.030–0.000

From: [6, 7, 10, 12, 13].

3.6.3 Low Temperature Cofired Ceramics

One common application area of ceramic materials is integrated passive components (IPCs), such as resonators, resistors, capacitors, and inductors. The electrical functionality of each of these components typically dictates that one of the following materials is selected for the construction of the device:

- Resonators: Possible materials include BaTi_4O_9 ($\epsilon_r = 38$), $\text{Ba}_2\text{Ti}_9\text{O}_{20}$ ($\epsilon_r = 40$), and $(\text{Zr-Sn})\text{TiO}_4$ ($\epsilon_r = 38$). Used as cylindrical blocks for oscillator frequency stabilization up to 50 GHz.
- Resistors: Generally comprised of ruthenium oxide (RuO_2) or tantalum oxide (Ta_2O_5).
- Capacitors: Generally comprised of silicates or titanates.
- Inductors: Generally metallic conductors in some spiral shape to provide inductance.

Demands for increasing circuit density are typically not met by these conventional manufacturing and packaging technologies. One trend in the development of IPCs is to integrate layers of multiple dielectric-constant materials within one substrate. Nowadays, low temperature cofired ceramics (LTCC) display the widest range of dielectric properties available for any packaging technology, enabling the incorporation of passive components. Furthermore, LTCC technology can incorporate resistive materials, thus enabling the integration of both resistors and capacitors within the substrate.

Cofired ceramics offer many advantages for achieving higher packaging densities in RF/microwave and digital integrated circuits. The integration of high-speed digital and DC-power circuits along with RF/microwave structures using cofired ceramics, for example, is becoming common practice for many wireless and microwave module applications. One of the significant advantages of a waveguide structure over printed transmission lines is the lower insertion loss characteristic it provides. While desirable for low-loss filter applications, a waveguide can be embedded into multilayer cofired ceramic assemblies without significant crosstalk. Additionally, these structures can be efficiently transitioned to other transmission lines, such as microstrip or stripline. One further possible ceramic material is calcium borosilicate.

It is possible to embed high dielectric-constant materials within lower dielectric-constant, insulating materials. In one promising packaging technology, three dielectric-constant materials, BaTiO_3 , CaTiO_3 , and magnesium silicate (Mg_2SiO_4) are integrated. In order to make cofiring possible, constituent ceramic materials are sintered at the same temperature.

LTCC was developed as an enhancement of thick film hybrid technology and has been significantly improved over the years. It provides high reliability, as well as the design flexibility to realize true three-dimensional structures (unattainable with polymers and conventional ceramic materials) and to incorporate capacitive and resistive components within a hermetic device. Certain types of LTCC also feature the low microwave loss characteristics required for wireless communication devices. While some of these solutions have been used in high-frequency military and aerospace applications only, they could not, however, be manufactured in high volumes and have traditionally been unable to meet the cost requirements for consumer applications. An important way to minimize microwave losses in LTCC components is the use of silver as the conductor material. Tests have shown that the new LTCC tapes incorporating the silver conductor system offer both the

required cost reduction and a significant electrical performance advantage, making it suitable for use in consumer wireless equipment.

It is obvious that the continuous demands for miniaturization of RF component packaging will push the development of further LTCC techniques and manufacturing facilities.

References

- [1] Collin, R., *Foundations for Microwave Engineering*, New York: McGraw-Hill, 1992.
- [2] Voipio, E., *Sähkö- ja magneettikentät*, Espoo, Finland: Otakustantamo, 1976.
- [3] <http://www.reade.com/Products/Alloys/invar.html>.
- [4] <http://www.edfagan.com/htmDocs/inv.htm>.
- [5] <http://www.goodfellow.com/static/A/FE02.HTML>.
- [6] MEMS Clearinghouse, *Material Database*, <http://www.memsnet.org/material>, Feb. 26, 2002.
- [7] MatWeb, *The Online Materials Information Resource*, <http://www.matweb.com/link.htm>, Jan. 24, 2002.
- [8] Outokumpu Ltd., “Drawn Products,” <http://www.outokumpu.com/copper/drawn2.htm>, Feb. 26, 2002.
- [9] Eskelinen, H., P. Eskelinen, and K. Tiihonen, “Application of Concurrent Engineering in Innovative Manufacturing and Design of a Milled Microwave Filter Construction,” *Proc. 4th Int. Conference Managing Innovative Manufacturing*, Birmingham, UK, Jul. 17–19, 2000, pp. 230–236.
- [10] ESPI, *Online Catalog*, <http://www.metals.about.com/cs/properties>, Feb. 24, 2002.
- [11] *Suhner RF Connector Guide*, Switzerland: Huber and Suhner AG, 1997.
- [12] Ceradyne Inc., *Advanced Technical Ceramics*, <http://www.ceradyne.com/dtsic.htm>, Jan. 10, 2002.
- [13] Communication Media Components Group, *Material Characteristics*, <http://www.ntktech.com>, Dec. 10, 2001.
- [14] Kalpakjian, S., and S. Schmid, *Manufacturing Engineering and Technology*, New Jersey: Prentice-Hall Inc., 2000.
- [15] Wright, P. K., *21st Century Manufacturing*, New Jersey: Prentice Hall Inc., 2001.
- [16] Farag, M. M., *Materials Selection for Engineering Design*, London, England: Prentice Hall, 1997.

4

Computer-Aided Environment for Design Work

In principle, the general advantages achieved by using computer-aided tools during a design process can be classified into three groups as follows:

1. General advantages of electronic data processing (EDP);
2. General advantages of open CAD applications;
3. Advantages of CAD applications for specified design areas or tasks.

The general advantages of EDP are usually connected to, for example, the needs of processing huge amounts of data, access routines, and networking possibilities. This is the principal environment that should be further developed towards an effective design practice. The general properties or advantages of open CAD applications in microwave mechanics are actually the basic CAD functions (in either 2-D or 3-D), which allow the designer to model or design something. Typical commands to carry out these functions include “mirror,” “rotate,” “hatch,” “scale,” or “multiple.” These properties are mainly developed to reduce unnecessary redrawing during a design process. There are only insignificant differences between respective commands or functions in the most common commercial CAD applications. It is obvious that modern EDP facilities and an open CAD application are needed for effective design. Microwave mechanics would also benefit of some

additional properties, which should be built into the CAD application or, if that is not possible, into a combined software package.

It is also important to understand the structure of the microwave design process inside the computer-aided environment, which is supported with appropriately specified CAD applications. This structure can be described in the form of a design chain as illustrated in Figure 4.1 for a laser processed microwave component. This chain includes both the computer-aided manufacturing data and the performance simulation results of the microwave device. In the next few chapters, we will discuss this integration in detail and some practical examples will be presented.

4.1 Integration of Basic CAD Tools

A modern product designer works in a CAD environment in which the purpose is to increase the effectiveness of the total development cycle starting from the first sketch and ending at the final manufacturing process. To be able to utilize this environment, the designer must have a good knowledge of engineering, modern manufacturing technologies, and of course about the use of different computer-aided tools.

Trebilcock and Morris [1] introduce a design methodology that utilizes AI. They describe the mechanisms employed within a methodology for capturing product knowledge in the conceptual design environment. They

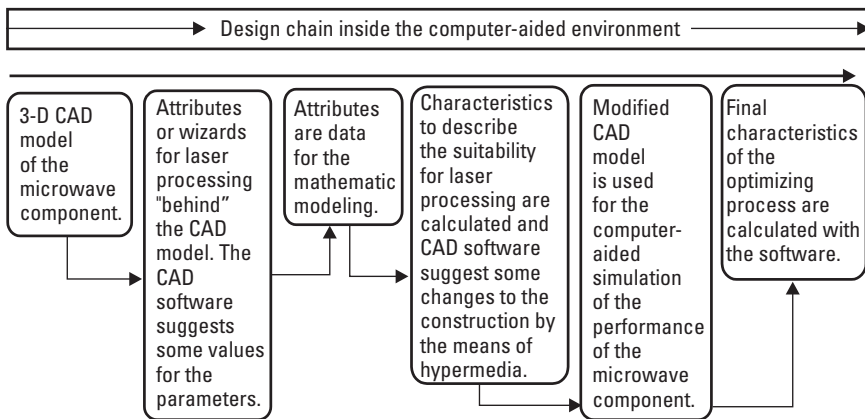

Figure 4.1 The structure of the microwave mechanics design chain. A laser processed component is used as an example [2].

present the operation of a meta-rule base, the purpose of which is to facilitate the generation of practical design constraints. This base also gives a description of a structure and a manufacturing rule base and the interaction of these two with the case base environment.

Lefort and Kesavadas [3] have done research work in the area of utilizing virtual environments especially in manufacturing automation. They present a model of a virtual factory, which consists of a set of modular machines. The designer can drag and place these machines on the factory floor to study issues such as plant layout, clusters, and part flow analysis.

One example of an application for computer-aided knowledge-based material selection is presented by Trethewey [4]. A methodology for the construction of a generic computer algorithm is shown. It is based on a knowledge structure in which material selection and failure analysis are at opposite ends of a spectrum of material performance.

The integration problem between CAD and CAE, which has also come up during this compilation work, has been studied by Peak [5]. The claim is made that, because of the present gap between CAD and CAE, designers are often hindered in their efforts to explore alternatives and ensure product robustness. To solve this problem, Peak describes the multirepresentation architecture (MRA)—a design-analysis integration strategy that views CAD/CAE integration as an information-intensive mapping between models for design and analysis. During the past few years, however, one additional problem has turned up—there is also a lack of AutoCAD-integrated (compatibility for DWG file import) software for modeling microwave electronics. This means that it is difficult to integrate the geometric modeling and the finite element analysis (FEA) of a mechanical microwave device, and it is also problematic to combine geometric modeling with electromagnetic modeling.

Ehrlich and Lilegdon [6] present a working simulation system for the Windows[®] environment designed specifically to support manufacturing decisions. All of the model data is stored in a Microsoft Access database. The system includes, for example, machines, operators, materials, parts, job steps, process plans (routings), and conveyors. In addition, a comprehensive set of predefined manufacturing rules is available. All phases happen in the Windows environment.

Two types of compatibility are needed:

1. All of the software packages used in a design process and all of the data that flows between them must be fully compatible.
2. The user interfaces for different applications must be fully compatible as well.

The problem of handling different versions of computer-aided engineering documents is common nowadays. Even new standards for documentation include instructions to ensure the control of different versions. Krishnamurthy and Law [7] have presented one model to handle the different versions in the CAD paradigm.

Visualization of manufacturing processes has usually occurred in different casting processes in which the geometry of the workpiece can be very complex. These applications typically utilize 3-D modeling. Even though casting is an obvious area for visualizing the manufacturing process beforehand, any manufacturing process that utilizes, for example, 3-D robotic applications, could be checked in the same way.

Lu [8] claims that, in many cases, the manufacturability of a product is not considered until the design has been nearly completed and detailed. Lu states that this is due to the limited capability of current computer-aided engineering tools to support design evaluation, especially during preliminary design. Lu presents a volume-based geometric reasoning and visualization approach to handle this task. It has been proven that there is still a lack of powerful software that would support the design of laser processed products.

According to our own opinion, the development work is concentrated only on one specific area of utilizing computer-aided means in engineering. Or, on the other hand, it seems that the development is made only from the data processing point of view and mechanical or electrical engineering is forgotten. An integrated model of computer-aided means is needed. Additionally, Montau and Flemming [9] found that a new concept for product data management, based on the combination of both methods from design theory and information technology, is necessary.

Figure 4.2 shows a schematic picture that illustrates the basic integrated structure of the computer-aided design environment. From this visual presentation the following topics are pointed out:

1. It is necessary to avoid the modeling of the same geometry several times during the practical process. Instead, we want a way to use the same model in every stage of the flowchart. The model, however, will be improved or completed during the process. This means that it must be possible to fully integrate all the software packages used in the process. That is why modular software applications are favored. They link sketching, drafting, design, FEA, and manufacturing simulation.
2. All the data produced during the process should be saved in a local database, which forms the backbone for the further development of

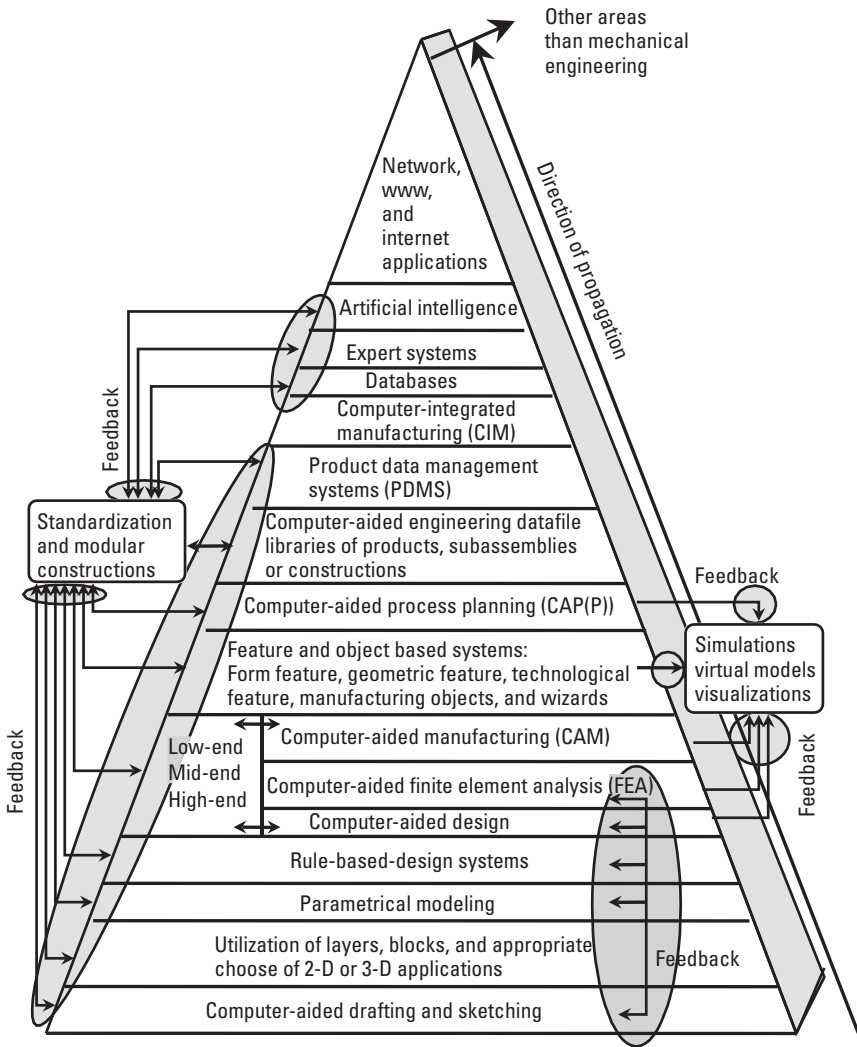

Figure 4.2 A schematic picture that illustrates the basic, integrated way of proceeding in the computer-aided design environment. Those nodes of the computer-aided design environment in which SPC can be carried out are circled with gray ellipses [10].

more general databases, expert systems, and artificial intelligence systems. On the other hand, by combining the data from databases, the designer can formulate standard-based or modular constructions starting from the sketch in the very early stages of the design

process. These databases should be compatible with those of all the suppliers and customers.

3. The use of standardized and modular constructions forms the important starting point for computer-aided design as well. It is easy to add feature-based information into the data of standard components, parts, subassemblies, or the entire construction, to be used for the design of manufacturing or for process planning.
4. Different kinds of simulations and visualizations are used to illustrate the propagation of the design process. By using virtual models, it is possible to combine geometrical, physical, functional, and manufacturability simulations of a product. If, however, the simulations or virtual models are used only for replacing the conventional drawbacks due to a contradiction between the designer and manufacturer, very little advantage will be achieved with “computer-aided drawback.” In this case, more time will be wasted on modeling than would have been spent in useful conversations with the people from the manufacturing plant.
5. To make the early steps of the design more effective, either parametrical modeling or rule-based design systems can be used. Of course the appropriate use of blocks (either blocks created by the designer or, possibly, ready-to-use blocks) and layers will improve the efficiency of the actual work with the computer.
6. The most effective way to shorten the time needed to complete the product documents for manufacturing is the use of feature-based systems. Form features (e.g., not just the sphere but a sphere of a ball bearing), geometric features (e.g., not just the dimensions of a bored hole but also the direction of this cylinder), or technological features (e.g., data of materials or tolerances) can be utilized. The model of the product can also contain information in the form of manufacturing objects (in the data-added subprograms for manufacturing a specific geometry) or wizards (the software suggests the possible manufacturing methods and the user chooses the appropriate one).
7. CAD/CAM programs are typically divided into three levels: low-end, mid-end, and high-end programs. The low-end programs include only a light version of a 2-D modeler and a viewer, the mid-end level programs include both the 3-D modeler and CAD/CAM-integration module, and the high-end programs also

have the basic properties of product data management (through the various design stages).

8. Both local and global networks are needed. Nowadays, Internet applications have become common in different areas. The basic problem, however, in the use of networking for engineering design is still a question of data security.
9. The model presented in Figure 4.2 works well when the task is to design or modify constructions or product ranges to be built of standardized or modular components. When the target is a totally new product or when some modern manufacturing methods are intended to be used, it is possible that databases do not include enough information, for example, a feature- or rule-based modeling or for computer-aided process planning (CAP(P)). A very limited number of appropriate databases or CAE libraries is available for microwave mechanics.

During the last few years, the importance of CAE documents has been questioned. Traditional drawings, 3-D models, or virtual models, however, still include, in principle, all of the input data of the design process and all of the output data as well. This means that when emphasizing the effectiveness of a design process, more attention should be given to drawings or models that are real results. Steffen [11] suggest that statistical process control (SPC) can be used to quantify and improve mechanical drawings even though they present (hopefully) some creative work. In Figure 4.2, the nodes of a computer-aided design environment where some practical SPC can be carried out are illustrated with gray ellipses.

According to Steffen, the improvement process can be divided into three stages:

1. Flow-charting the design (drawing) procedure to find the input and output points and the required feedback (which are indicators of rework);
2. Drafter collects the input errors, checker collects the output errors, additional information is collected from everyone working with drawings, and finally statistical scatter diagrams, histograms, and Paretos are formed to illustrate which errors have occurred at which stages and from which reasons;
3. Process improvements are chosen according to results from the first two stages.

4.1.1 Interaction Between Virtual Engineering and Hypermedia Applications in Controlling Heat Input During Welding of Microwave Components

The modern CAD environment of welded microwave components consists of three main parts:

1. Hypermedia-based databases (microwave mechanical data, welding data, and heat treatment data);
2. Computer-aided FEA results for different heat transformation cases (e.g., for heat input due to different welding processes or a material's metallurgical behavior due to different heat treatments);
3. Virtual engineering (VE) for performance simulations of the microwave device.

Many people consider the terms hypertext and hypermedia synonymous. Nominally, hypertext refers to relating textual elements, while hypermedia encompasses relationships among elements of any media type. The concepts are identical, though hypertext is more difficult to implement in nontextual media. Hypermedia can also be considered as an abbreviation, which combines the words hypertext and multimedia. Although hypertext suggests that all information is in the form of plain text, most hypertext systems allow the use of information in other forms, such as graphics, sound, animation, or video. It is important to understand that hypertext is really a database. The information is not simply a bucket full of bytes, but is structured, and also large, much like the information stored in most databases. Although the structure of the information is different from that of the more common administrative databases, most current-generation database systems are capable of storing the information used in hypermedia systems. Hypertext is the concept of interrelating information elements and using these links to access related pieces of information. An information element or node can range from a single idea or chunk to an entire document. A hypertext is a collection or web of interrelated or linked nodes. A hypertext system allows an author to create the nodes and the links between them, and allows a reader to traverse these links, (i.e., to navigate from one node to another using these links). Typically, hypertext systems mark link access points or link anchors in some manner within a node when displaying it on a computer screen (e.g., underlined text displayed within documents on WWW browsers).

In general, virtual reality (VR) is a computer-generated simulation of a real or imagined three-dimensional environment that is user interactive. The level at which users can interact is dependent upon the available hardware. Currently it is possible for users to immerse themselves in these simulated

environments. VE can be regarded as a limited part of VR. The world of VE includes only virtual mechanisms, engines, and MW devices, for example, which the user can control interactively with the computer. The functions of each virtual mechanism or device can be simulated on the screen without manufacturing a real prototype.

Let's see how to utilize these computer-aided tools in the design of a rectangular quarter wave patch antenna element (operating as a radiating element) and when arranging a complete planar 4×4 matrix (see Figures 4.3 and 4.4).

The points of interest are:

1. The welding deformations of the ground plane;
2. Metallurgical changes due to welding near the joint between the radiating elements and the ground plane;



Figure 4.3 A cut section of a rectangular quarter wave patch element, which is used as a part of a planar 4×4 matrix in the final antenna construction. The points of interest are: (1) welding deformations, and (2) metallurgical changes due to the welded joints between the radiating elements (L-geometry) and the ground plane.



Figure 4.4 A planar 4×4 antenna matrix made of quarter wave patch elements [12].

3. The solutions for handling these uncertainties with appropriate heat treatments.

The use of FEA for strength calculations is probably the most well-known assisting tool for the designer of welded steel constructions. In practical engineering design, FEA is also often utilized for estimating welding deformations due to heat input and, nowadays, also for analyzing the metallurgical changes in heat-affected zones (HAZ). It is also useful to estimate the effects of different heat treatments with the same FEA model. Too little attention, however, has been given to the possibility of utilizing interaction between VE and hypermedia applications.

Typically, virtual prototypes are used, for example, to test the performance of different control systems, or to design optimal mechanisms to fill specific accuracy requirements. Modern VE also enables the use of a computer-aided environment to find suitable manufacturing methods and heat treatments and, also, the optimal structural properties of a welded construction. The main weldability aspects due to geometry can be checked during the 3-D modeling of a construction. Furthermore, after selecting materials, thicknesses, and joint geometries, some commercial CAD programs offer the option to pick up wizards, which suggest welding parameters and alternative processes. If appropriate hypermedia databases for the selected material are available, it seems to be more than reasonable to combine the heat treatment and the weldability analysis. According to our preliminary results, it is possible, at least in some cases, to shorten the design time by 20 to 40% with the help of hypermedia applications. They can help, for example, to avoid some specific deformations due to exceedingly high heat input or due to improper weld dimensions. Thus, the technical documentation of the microwave component also includes the appropriate data for preheat treatments or postheat treatments.

Probably the most important result is that the functional effects of the metallurgical changes due to heat input can be predicted and visualized. An appropriate heat treatment can be chosen to ensure the electromagnetic properties of the welded joint in a microwave component. Hypermedia databases include some geometries that repeat time after time in welded constructions. The expected principal behavior due to welding heat input or due to different heat treatments can be visualized with the means of hypermedia without time-consuming FEA. If some unwanted changes are observed in the hypermedia presentation, the designer can improve the construction, supplement welding instructions, or choose heat treatments by utilizing the database library. The hypermedia-based library data nodes are interactively

improved (filled or combined) by the means of hypermedia itself, so that these integrated solutions will automatically be in use with the next design tasks.

Traditionally, hypermedia applications have been widely used for welding education, and the results seem to be promising. The applications that transfer information about health and safety aspects of welding, for example, have been proven effective. Hypermedia also looks reasonable for selecting heat treatments. Nowadays, hypermedia applications have proven to be useful when the aim, for example, is to make the industrial assembly stages of a complicated product easier to understand. These successful new fields have probably also encouraged scientists to build hypermedia environments for so-called high-technology areas or for product design purposes where more multidisciplinary problems are to be solved.

A cost-effective welding design utilizing hypermedia requires that the following conditions are satisfied:

- The whole design process is carried out in a computer-aided environment, and the software integration between the CAD/CAE, FEA, VE, and hypermedia applications is properly and hierarchically built.
- Databases that enable the utilization of hypermedia are wide enough to cover the field of design problems.
- The engineer has enough know-how about how to use hypermedia and of course about welding technology.
- Computer's hardware properties are efficient enough (compared to the requirements in conventional CAE work).
- The networking facilities for both local and global environment are in use.

When thinking about the design process and selecting appropriate heat treatments for a welded microwave component, the main advantages of using hypermedia are seen as follows:

- Time-wasting and money-wasting FEA can be avoided in cases where the principal solution (e.g., of deformations, residual stresses, or metallurgical changes) is enough to demonstrate either the critical point of the construction or the critical design path, and whether these results can lead to selecting appropriate heat treatment instructions.

- Possible joint geometries are demonstrated in an illustrative way (either two- or three-dimensionally) and basic geometries can be copied from the hypermedia application to the actual CAE software by a simple clipboard action.
- Parametric modeling can be carried out either directly in the CAE environment or, if necessary, the welding parameters can be found from the hypermedia library.
- There is no need to model the same geometry several times (e.g., for geometrical design, for heat transform analysis, for metallurgical analysis, or for microwave performance analysis) or gather information for welding procedure specification (WPS) forms several times, because databases are used interactively and new designs are connected to the hypermedia nodes to be used in similar tasks later.

VE should be regarded as a tool for effective engineering design even though it is presented as a novel design method in some contexts. The main purpose of VE is probably to animate, simulate, and visualize difficult phenomena, independent of their scientific origin. VE makes it possible, or at least easier, to analyze problems and find solutions without making any practical prototypes or products. The problems are to be solved on the computer screen instead. Currently, VE is mainly found in the design of mechanisms. In welding technology, two main areas that really need effective VE can be seen—metallurgical problems and the problems of heat input, which cause deformations and residual stresses. For a designer, VE allows the possibility of analyzing these problems and, of course, of trying to find reasonable solutions (e.g., by using different heat treatments), on a screen before any practical products are manufactured. A minor advantage can be also seen in the field of assembly where VE can be used to ensure that aspects of effective DFMA are taken into account.

Design problems of welded devices can be roughly divided into two categories:

1. Weldability aspects of the involved materials (metallurgical changes);
2. Functional aspects (strength of the joint and deformations of the construction) of the welded construction.

Both categories partly depend on the selection of appropriate heat treatments. This classification gives the justification for the integration and

interaction between virtual engineering and hypermedia. In practice, this means that we have to combine a software application that is developed for the specific microwave design task (to solve the actual electromagnetic design requirements) and the hypermedia application that includes the common but necessary welding and heat treatment information. If we manage to build up an environment where these three types of applications operate in the same computer-aided environment, the following advantages can be achieved:

- The electromagnetic effects of welding imperfections can also be simulated.
- The designer is able to simulate and analyze (1) microwave performance, (2) alternative construction designs, (3) alternative welding technologies, (4) weldability aspects, and (5) corresponding heat treatments with the same model.
- The designer is able to choose the best possible compromise of different materials, joint geometries, welding technologies, and necessary heat treatments with (it is important to emphasize) fewer or no physical prototypes needed.
- Documents to describe both the manufacturing process (including heat treatment instructions) and performance characteristics can be produced simultaneously.

Practical design work requires a cross-technological approach and the computer-aided environment enables the experts of different knowledge areas to work intensively together. A transfer of product ideas and practical solutions is fluent and reliable between designers. Our case example of antenna system design, for example, required cooperation between experts and designers of welding technology, microwave mechanics, and engineering design. A schematic flowchart of the interactive design environment for this case example is presented in Figure 4.5.

To reach an optimal performance of the test antenna, the following mechanical properties are highly important:

- Surfaces of the radiating elements and the ground plane should be parallel.
- The shorter sides of the radiating elements should be perpendicular to the ground plane.

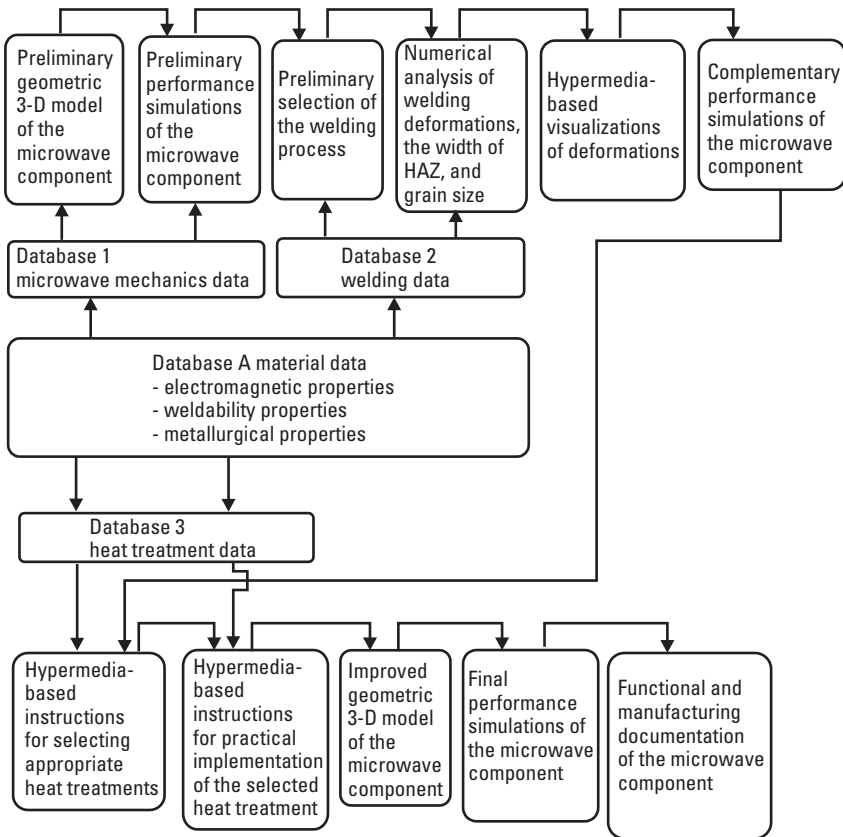

Figure 4.5 A schematic flowchart of the interactive design environment [12].

- The positioning tolerances of the coupling pin should be tight.
- Hardly any welding imperfections should be allowed in the joint between the radiating elements and the ground plane.
- The mechanical and metallurgical properties and dimensions of the radiating elements should be similar.

In practice it is impossible to meet all these requirements, absolute values are hard to gain, at least. Typically, the solution is found by adjusting the position of the coupling pin with the other tuning parameters of the antenna, which depend on material properties, geometrical uncertainties, welded joint geometry, and also on the metallurgical properties at the welded joint.

For this antenna design several combinations of materials, welding technologies, and heat treatments were tested and the corresponding tuning data for antenna constructions were collected in the database. We tested aluminum alloys and steels with laser, tungsten inert gas welding (TIG), metal inert/active gas welding (MIG/MAG), and resistance spot welding. In order to have a reference point, we also tested pressing with TOX joints (TOX-pressing process). Heat treatments were used after different welding processes to improve the straightness of the ground plane and the parallelism between patch elements radiating plane and the ground plane. (These joining technologies are explained in detail in Chapter 7.)

Simulations showed that the most critical welded areas regarding microwave performance are the start and the end points of the joints and the accurate positioning of the feeding point of each radiating element. This is illustrated by the surface current plots of Figure 4.6. During practical welding, no imperfections are allowed here.

It is more difficult to give exact instructions for controlling the deformations due to heat input during welding. For this purpose VE proved to be a powerful tool. The expected deformations of the ground plane due to welding heat input can be simulated and, by using appropriate heat treatments, different solutions can be visualized as presented in Figure 4.7.

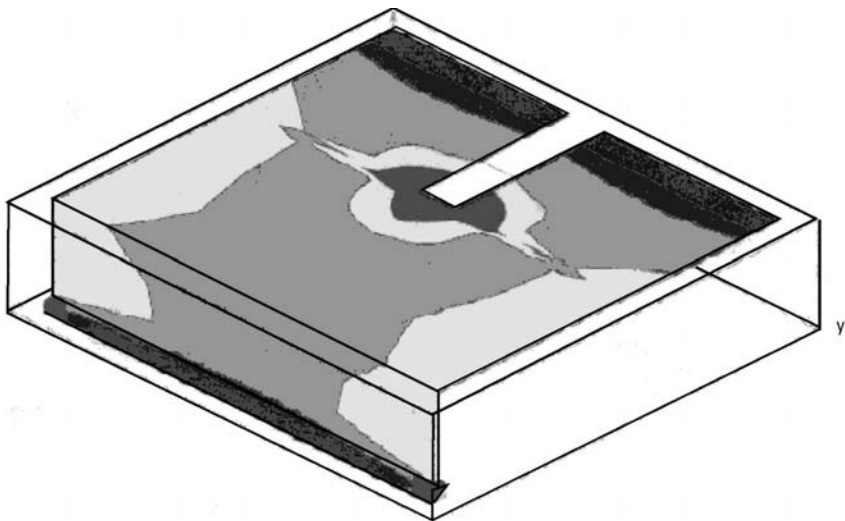

Figure 4.6 Microwave simulations indicated very high surface current densities at the two corners of the patch and at the feed-probe connection [12].

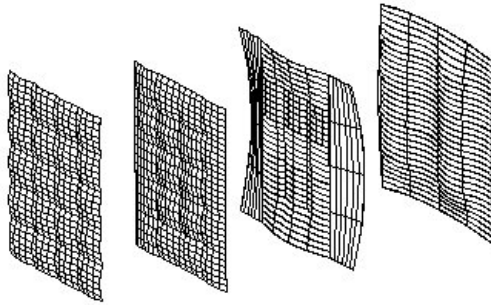

Figure 4.7 The expected deformations of the ground plane due to welding heat input can be simulated and, by using appropriate heat treatments, different solutions can be visualized (see 3-D models from right to left) [12].

4.1.2 Integration of Computer-Assisted Engineering and Microwave Mechanics Simulation in Welded Stripline Filter Design

The detailed technical documents and manufacturing drawings of this filter are presented on the attached CD-ROM. For that reason, it is not necessary to present the filter construction in detail here. Instead, let us just compose the previously mentioned design chain.

In this case example, the computer-aided design environments for traditional engineering design and microwave mechanics were integrated to simulate and ensure both the performance of the product and to check the weldability aspects for production efficiency.

In this filter, conducting strips are mounted between two parallel metal surfaces, and the conductor width together with the insulating material creates various suitable impedance values. This specific filter design is based on the theory presented by Zverev.

The design chain consists of the following integrated stages (see Figure 4.8):

- The simulation model of the electrical design of the filter (The model demonstrates the individual transmission lines and the test generator.);
- The functional simulation of the filter (The respective simulated behaviors can be seen, for example, in the form of curves.);
- The performance simulation of the filter (The appropriate dimensions for the strips, for example, can be defined by utilizing the simulation procedure.);

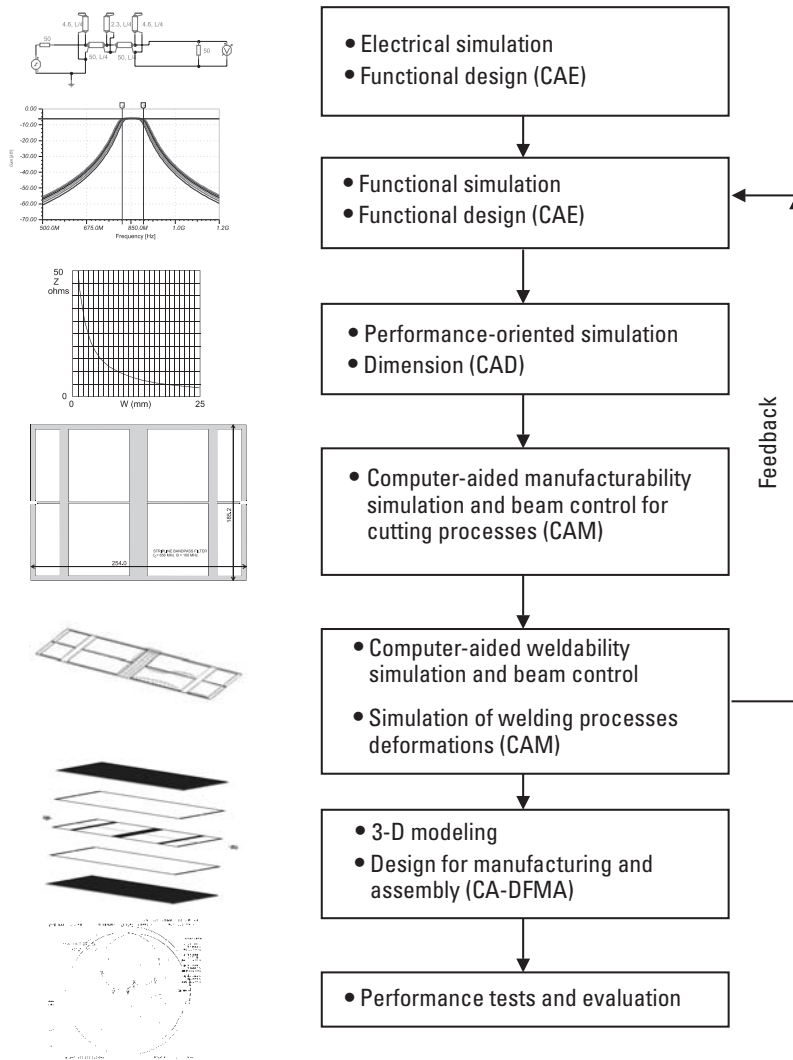

Figure 4.8 Integration of CAD, CAE, and CAM (in this case laser welding and cutting processes) procedures for microwave mechanics [13].

- The calculated dimensions are sent for manufacturability analysis (material and laser processing data are added.);
- Welding and cutting simulation (beam control and heat input data are added.);

- Assembly analysis (for individual parts and the construction as well.);
- Computer-aided performance test, evaluation and feedback.

4.2 Typical Simulation Software Solutions for Microwaves

Electromagnetic simulation is a solid technology for obtaining accurate results for analysis and to design complicated RF or microwave PCBs, antennas, high-speed digital circuits, and other relevant electronic components. Computer simulations have proven attractive both when size limitations have prevented measurements with real devices and for prototyping where a “real” thing might not yet exist. Traditionally, EM software developers divide their products into two categories: two-dimensional and three-dimensional environments. Recently, for cost reasons, newcomers have brought to market “2.5-D” simulators with a focus on multilayer planar constructions, which need (or allow) only limited structures along the z -axis. We approach the topic of practical passive microwave component simulation by introducing two commercially available environments. The first one is the IE3D, which is widely used (e.g., in the design of handset antennas). Large objects, such as complete ship hulls, aircraft frames, and hollow waveguides, can be handled by a software called FEKO. These two examples are not selected to present the properties of the best MW software. Instead, we want to emphasize here the importance of careful and objective comparison between various software packages. We also want to show the disadvantages of these applications. Although we limit our discussion to these two examples, most of the remarks are relatively common. A number of software packages had to be left out because their manufacturers could not provide the authors with a demonstration version.

IE3D is an integrated full-wave electromagnetic simulation and optimization environment intended for 3-D constructions such as filters, antennas, and monolithic microwave integrated circuits (MMICs). Its initial version was introduced in 1993, but the company continued upgrading, so we currently see version 7.0. The primary mathematical formulation “inside” it is, and has been, based on an integral equation obtained through the application of the dyadic Green’s function, manipulated to a matrix system suitable for computer processing. Although working in a world with a conductive layer at $z = 0$, this restriction can be canceled and simulations are possible in a true three-dimensional coordinate frame. The phantom of the layered structure pops up occasionally however.

This software uses its own program manager, under which the most important function seems to be the security key identification. Various sub-tasks can be started from it and after a session is over, the user returns here. The three major programs needed for design or analyzing tasks are the MGRID structure editor for the drawing of surfaces and elements to be used in the simulation, MODUA parameter display system and, finally, CURVIEW/PATTERNVIEW programs for the display of multicolor radiation patterns or surface current plots. The IE3D is advertised as being able to import general 3-D layout graphics from AutoCAD-type files, but this feature was not tested.

The IE3D package was tried with some simple constructions for which we had real measurement data available. These included a ring hybrid, a power divider, and a patch antenna. The three-dimensional drawing of the geometry to be simulated (actually done in two dimensions) is rather straightforward but somehow less fluent with the MGRID tool. The graphical user interface is not as comprehensive as, for example, in AutoCAD or similar mechanical design environments. It is usable, however, if stated rules and recommended practices are followed. The constructions did not contain complex curved surfaces, not even planes aligned in nonrectangular fashion, which might be cumbersome in the MGRID system. The difficulties with the geometrical entry are due to the multitude of available special functions and features requiring a user's fundamental commitment to the task. Something is still missing—for example, the system has no common RF or microwave connectors as a readymade subassembly. Although this kind of software is designed by engineers for engineers, the cultural gap between young code-makers and those of us working with actual devices and systems is wide enough to cause uncertainty and confusion.

The visualization tools of IE3D provide familiar Smith charts and frequency response plots, return loss graphs, and tabulated numerical data. For unknown reasons, it was not possible to change the presentation font, line widths, or the plot colors despite furious attempts. If more than one test port is created, the simulator displays all results simultaneously before operator intervention. The simulation accuracy was at least sufficient or even very good for selected test cases, but this required some consideration of the geometry and its modeling in MGRID. Typical errors in the patch impedance were 2 to 3Ω (out of 50) with an arbitrary angular difference. The simulated coupling attenuation in the hybrid was in error by only tenths of a decibel. The current density and pattern plots were comprehensive and their differences, when compared with actual measurements, could not be detected on the limited-size personal computer screen; assuming the deviations were below 1 dB. It was complicated, however, to adjust the scaling of

plots so as to display the relevant scale of values. It appeared that the adjustment provided did not work as expected. Plotting the graphs was a game of fortune; in particular, the dithered colors needed several retrials before the results on paper resembled those on the screen. We did not have these difficulties while using other software compilations.

The manual, which comes as separate sheets, is a wealth of information and has numerous illustrations. Many examples are demonstrated on a step-by-step basis and various limitations are pointed out with suggestions for alternatives. Preworked files are given from the area of radiating elements, complete cellular phone antenna patterns, and from millimeter wave integrated circuits. The manufacturer has conducted extensive tests, and there has been an attempt to verify the models used for simulation by actual real-life sample designs. For some reason, the manual contains frequent spelling mistakes and does not follow a solid grammar of the English language, but these features by no means reduce its usability.

The software was tested in a retired 166-MHz personal computer with 48 MB of RAM and in a considerably more modern 800-MHz/128-MB version. The results were just as predicted in the manual and as anticipated from my past experience. This IE3D simulation platform works best if the geometry is limited in nature and its meshing is carefully optimized. Otherwise, the processing will freeze the system for many minutes (two side-by-side patch antenna elements with a realistic feed) or for hours (a stripline filter having milling imperfections added). In the manual, both matrix size and simulation type have an impact on performance. We emphasize that, unlike two other simulation tools from well-known companies, this “modest” version worked without the ultimate Pentium power and did not call for unlimited memory resources.

According to the manufacturer, the IE3D software package is priced at \$6,000 for one user (university, nonprofit conditions). With all its features and limitations or characteristics, it is an attractive and feasible alternative when compared with its huge counterparts, which require roughly \$50,000 plus nearly unlimited platform resources—not often within the financial possibility of academic institutions.

Many of the currently available commercial electromagnetic simulation software packages are entirely, or at least mostly, focused on handling relatively small-sized items. Their application areas include microstrip circuit boards, MMIC's, and hand-held antennas. A key feature in most of these is the limited maximum physical distance as expressed in fractions of the appropriate wavelength. Large antenna structures, perhaps even with associated towers or radar cross sections of different platforms, are completely

outside the scope of these products. Alternatively, several known wide-scope software sets seem to be useful for almost any kind of wave or pattern simulation but suffer from a less attractive pricing. The recently introduced FEKO software steps roughly into this gap.

The acronym FEKO comes from German and could be translated as “Field Computation Involving Bodies of Arbitrary Shape.” As this implies, the software is intended for tasks where the target geometry is complicated and seldom can be presented, for example, as successive planar layers. Thus, the fundamental background is a full three-dimensional geometry that on one hand gives the best freedom for engineering but is, on the other hand, a most challenging environment to work in. In FEKO, electromagnetic fields are obtained by first calculating the electric surface currents for conductors and equivalent electric and magnetic currents for dielectrics. Based on these, the more interesting parameters, such as radiation patterns in the far or near field, radar cross sections, and input impedances of selected geometries are computed. Unlike some competitors, FEKO uses a hybridized form of physical optics, diffraction theory, and the method of moments (MoM). Therefore, electrically large problems can be discussed more efficiently than by the sole MoM scheme. Planar parts of vessels or aircraft could utilize, for example, the physical optics principle whereby the computational burden gets smaller, but details needing more accurate processing can be still handled by the MoM technique.

In our case the evaluation is based on the Windows version of FEKO, which includes a main user interface called WinFeko. First of all, the geometry and all required simulation data, such as frequencies and material properties, are written in simple character form by using a subset called EditFEKO. After this, two other subprograms must be launched by the user. PREFEKO performs the meshing and related topics, and FEKO Solver produces the requested output data. Following these steps, the user is advised to start GraphFEKO, which, as the name suggests, is the main visualizing tool that can plot radiation or radar cross section (RCS) patterns or the contents of scattering matrices. Two alternative approaches are available for creating the necessary device under test (DUT) geometry. The same CD-ROM contains a program called FEMAP (from a different vendor), which is a relatively comprehensive 3-D CAD package for general engineering use. Structures created in this environment can be transported to FEKO and used there as if they were a part of original FEKO code. Besides this, the EditFEKO subprogram is said to be capable of directly using AutoCAD files of plain data exchange format (DXF) type. This is expected to be a very interesting characteristic for RCS applications involving ships or airframes.

To be honest, we have selected this FEKO example just to warn the readers about the possible difficulties with some MW software. Although the creation of a new 3-D geometry looks pretty complicated at a first glance, we were able to handle this part of the user interface after two days of hectic trial and error. Two different methods are available. If one is fascinated by small Windows-like buttons and pop-up menus, the left corner of the screen can operate as a tool in which most of the required geometry commands are waiting for a rapid launch. This is a way to reduce the list of parameters one has to remember since EditFEKO asks for the necessary ones after the user has opened any of the inputs. Thus, for example, a point in the 3-D space is sure to get all three of its required coordinate values. If, however, the user prefers to stick to the more conventional “writing-style” supported, for example, in Matlab, this is also possible on the main editing area of the screen. Here the user must definitely take care to use the correct syntax because no live error-checking is performed.

In EditFEKO, a particularly nasty characteristic is the requirement of proper writing of individual data values regarding tabulator positions in the text field. According to our experiences, a foolproof way of circumventing these difficulties is to proceed with an existing geometry file and perform the necessary modifications to it rather than start from scratch. Regardless of creational background, the geometry can be in a fully parametric form and individual coordinates can be derived from variables. This makes optimization, for example, much easier and provides useful ways to implement geometrical deformations. Some users may not like the way that FEKO takes care of meshing requirements. In the current software version, the user has to keep track, on the electrical connection, for example, of triangle corners and individual wire segments, if needed in the design. This seems to lead to rather tedious, successive meshing or segmentation attempts. One way to avoid excessive problems might be a continuous use of symmetry, which might force the meshing into a better harmony. No special tool was found in FEKO itself for forced meshing.

Simulation times of selected structures were very short indeed. A complex 3-D cubical arrangement having maximum physical dimensions above two wavelengths required just 200 ms for 10 frequency points on the 800-MHz laptop Pentium. Within this time frame, both surface currents and radiation patterns were computed. Test cases included a straight rectangular waveguide, a circular feed, and a missile nose-cone (for RCS). It looks like the proposed hybrid approach would really give computational benefits when compared to other “middle-class” packages. On several occasions, the solver got stuck without any result at all. This was due to improper

geometrical definitions suggested by the user during the edit phase or due to the frequent meshing violations, which seem to be one of the less pleasing features of this software.

Much of the still relatively high level of user-inconvenience when working with the FEKO package is caused by a Windows interface being “under construction.” For example, when returning from the solver environment and wanting to launch some graphical visualization, no help texts appear on the buttons if pointed at with the mouse. If, however, the user first clicks twice on, for example, “File” (which theoretically causes nothing), normal operation is sustained. Then, if we select “Antenna Parameters,” whereby GraphFEKO is launched, and select the correct output file for data, for some curious reason, we come to a display asking for “Main Graph Settings.” Possibly a more logical approach would be to show, for example, a brief visual summary of available data. Some of the dialog boxes (e.g., for scaling) did not perform as expected, and a solid curve plot of input impedance was apparently too difficult to locate. A rather serious problem was observed when trying to view the actual 3-D model of the test structure. First of all, it was not visible anywhere in the WinFEKO screen unless (actually by accident) a render test was performed. Additionally, a comprehensive viewing and rotating of the structure successively halted the whole computer, and only a hard reset could restore normal operation. Sometimes the user was also able to reverse the coordinate frame permanently into a non-righthand convention.

It seems that the developers of the original algorithms have tried hard to make their product a reliable one. The *User's Guide* (containing 336 pages) is written in an explanatory style, but sometimes it suffers from poor readability—perhaps because the original version has been translated from German into English. Similar bugs appear in the *Getting Started Guide* but by no means lower its usability. A separate *Examples Guide* has been provided, as well. About 40 practical cases are shown, all of which are included as ready-made code as well. One characteristic feature in most of them is their large physical size in terms of wavelength that certainly encourages the user to try various RCS computations of real-like objects. As opposed to some other commercial products, the FEKO people honestly state a list of possible problems in obtaining the required accuracy of simulations and suggest various means of making confirming checks.

The FEKO suite is interesting as an entity. Applications could range from wire, horn, or aperture antennas to antenna placement on vessels or aircraft, and further to RCS simulations. Because of the implemented lumped passive components, coated wires, and a small time-domain utility [based on

a frequency sweep and fast Fourier transform (FFT)], this software might find use in electromagnetic compatibility (EMC) analysis as well. Many of the supplied examples deal with antennas close to dielectric structures which indicates feasible applications, for example, in the field of specific absorption (SAR) calculation. FEKO is not the easiest software and requires thorough familiarization before real productive simulations can be expected. Typical users of this \$3,500 (academic list price) package could be designers of radar and military vehicles, planners of complete tower-mounted antennas, and particularly students who should feel at home with the slightly tricky code.

4.3 Integration Problems of Current CAD Applications

4.3.1 Problems in CAD Applications Made for General Mechanical Engineering

When designing microwave products, the most serious defects of the current mechanical CAD applications can be divided into two categories.

Problems with databases include:

1. Practically no 3-D models of standardized microwave connectors, mounting screws, or electric components can be found in the databases.
2. Most common libraries do not include the necessary data for:
 - Materials or bulk sizes used for microwave applications;
 - Mounting screws and mounting holes (due to inch-based dimensioning);
 - U.S. standards, which should be used as references;
 - Cables and connectors.

Problems with data transform or translation include:

1. The tolerance limits cannot be translated directly into the CAM files to ensure that the fittings would work properly or to simulate assembly.
2. If any additional software is used with, for example, an AutoCAD-application, most of the specified blocks or symbols are misunderstood after data transfer.
3. If geometrical data is to be transferred into any known microwave application, three main problems will be met:

- Scaling could mutate at least in one main direction (x, y, z).
- Typically, the coordinate directions differ from the original one (z -axis direction will be changed).
- No material data is included with the model.

4.3.2 Problems in CAD Applications Developed for Microwave Design

General-purpose electromagnetic simulation software packages focus on designing and analyzing problems near the chip level, which means dimensions of fractions of a wavelength. Other typical simulation targets, such as mobile phones, connectors, microstrip filters, or couplers, are often limited to less than one or two free-space wavelengths. Antenna design would also benefit from numerical estimations, but normally the physical size is measured as several or several tens of wavelengths and the constructions are true 3-D structures. Particularly challenging topics, both for radio frequency engineering and for numerical modeling, are extremely wideband antennas intended for impulse radar or radio applications, which is treated, for example, in Le Goff and Pouligen [14], Lostanlen [15], Gustavsson [16], and Thaysen [17]. For such purposes, Duzdar and Kompa [18] describe a trapezoidal antenna which was used here as a test case for the evaluation of a software ensemble from IE3D [19].

The reproduced basic unit is shown in Figure 4.9. It measures roughly 270 mm in width, 130 mm in height, and the connector is mounted on a

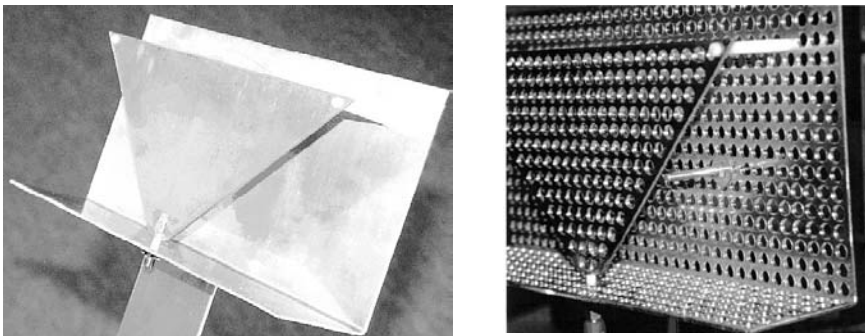

Figure 4.9 A trapezoidal impulse radar antenna made of sheet aluminum was used as a test case. An improvement of the impedance match over the entire operating bandwidth was obtained with tuning screws near the middle of the triangle's edge (right).

50-mm deep ground plane. The trapezoid has an opening angle of 90° and it is supported by two PTFE bolts. Comprehensive verification measurements were carried out, partly following Marti-Canales [20], Yarov [21] and de Jongh [22], but partly in a conventional fashion in order to improve the carrier-to-noise ratio. A frequency range from 1 to more than 5 GHz was obtained and the gain was 8 dBi. Although an impressive operating bandwidth was already demonstrated in [18], it is obvious that high-power operation with SWR values near 2 may create problems either due to voltage stress within the feed system or due to output amplifier overloading. We tried to find a way to improve the impedance match, particularly between 1.6 and 2.1 GHz. It turned out that a 4-mm tuning screw, coming through the back-plane at the edge of the triangular radiating element and protruding up to a distance of 3 mm from its surface, as shown in Figure 4.10, provides a wanted reduction of reflection and as such does not alter the radiation performance too much. Our tuning method limits the SWR to about 1.5 and it is particularly effective at the problematic S-band part.

The simulation software [19] runs under Windows 98 or 2000. In our case, we used a 800-MHz Pentium III platform which has 192 MB of RAM and 10 GB of free hard disk space. All unnecessary tasks were shut down before starting the actual simulation runs. The numerical treatment is based on the common procedure of dividing the structure into small cells and solving (e.g., the surface currents) for each of them. Traditionally, the more cells we use, the more accurate we are, but it also means more stuff to compute. As warned by the manufacturer, there is a practical limit for the number of discretization cells after which the available RAM in the platform will be exhausted and the software will start to swap data through the hard disk. In our tests, we thus pushed the discretization as close to this trigger point as feasible, while taking care not to exceed it.

As the largest dimension of the antenna under test is almost five wavelengths at the desired upper operating frequency, it was impossible to simulate the whole construction with a reasonable combination of discretization resolution and time. We found, however, that for input impedance, it is possible to simplify the initial design of Figure 4.9 for the simulation task by leaving out the reflector and turning the trapezoidal element perpendicular to an infinite ground plane. This is illustrated in Figure 4.10 (top) where we show how the simulated SWR behaves as a function of frequency for two cell counts. We observed that both the average SWR value and its general trends were simulated in the same way even though the time needed—proportional to the square of the number of cells—falls to one third. The accuracy is not very good even when we use the highest practical discretization when

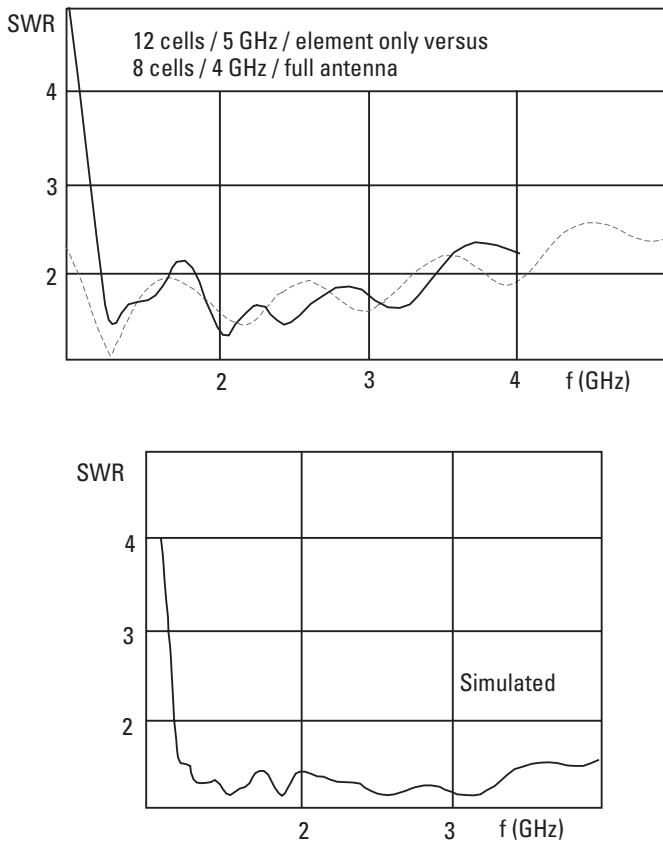

Figure 4.10 When only approximate results are needed, we can just model the areas of high current density. Both the average SWR and the trend as a function of frequency agree for a complete antenna (solid curve) and the radiating element alone (dashed, top). We were unable to model the geometry in order to approach the measured result at, for example, 1.8 GHz (bottom).

we select a real measurement as a reference. The plot at the bottom of Figure 4.10 demonstrates how, for a tuned full trapezoid and its reflector the software gives a misleading trend of SWR at frequencies above 3 GHz and also exaggerates the maximum at 1.8 GHz.

Due to the internal arrangements of the software, it does not help much if the upper frequency limit is cut to make room for a higher number of computation cells. This is shown in Figure 4.11 (top) where we have used the maximum number of 15 cells per wavelength but still do not obtain

correlated results. Note that there is a rather radical jump at 1.7 GHz and that the frequency range below 1.3 GHz is thoroughly misleading. The positive observation is that, inside the simulation environment, we have a good coherence. The plot at the bottom of Figure 4.11 shows how the tuning principle, initially invented by classical trial and error, really works in a predictive way in the software environment as well. Only the absolute SWR values are more or less useless.

It seems that this special wideband construction would have needed a more comprehensive preparation for the simulation. This comes clear from the Smith charts of Figure 4.12. The top cyclic plot is a result of a vector network analyzer measurement, whereas the bottom curve is simulated. One obvious reason for inconsistency is the rather arbitrary reference plane of the

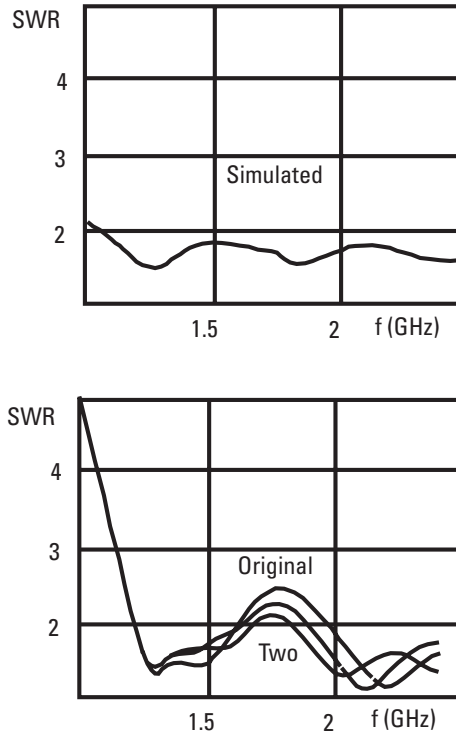

Figure 4.11 The simulation is not improved even if we increase the number of cells to 15 per wavelength and use a simple construction with no tuning screws (top). Internal intercomparisons seem to be the strongest point of impedance simulations for wideband antennas. Three cases are shown (bottom) with the modified design (two tuning screws) on the bottom.

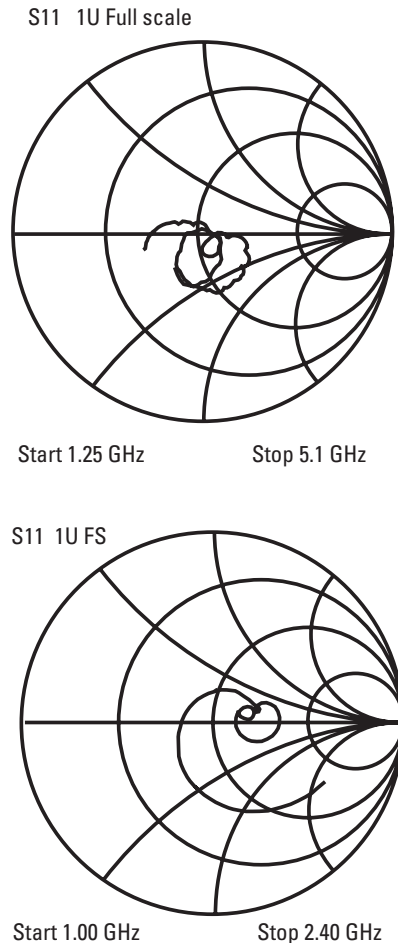

Figure 4.12 Considerable differences may be seen between real (top) and simulated complex impedances due to, for example, the somewhat arbitrary position of the reference plane. Much of the discrepancy can be attributed to the simplified ground plane—a restriction set by the overly slow 800-MHz processor.

simulation. Another real drawback is the fact that the computational power required for an accurate model of the ground plane exceeded by an order of magnitude that is provided by the 800-MHz Pentium processor.

An accurate impedance simulation of wideband antennas operating in the lower microwave frequencies requires huge amounts of computing power and the working efficiency is generally poor. About 4 to 5 hours are typically needed for a reasonable convergence when an 800-MHz platform is used,

but often as much as 12 to 14 hours are not enough. Inside the simulation environment, the obtained results (e.g., SWR) provide a useful tool for optimization, but for the selected test case there is not much correlation with the real measured values. Most adaptive curve-fitting schemes fail on the Smith chart due to the cyclic nature of the response. Thus only a small enough frequency step will improve accuracy whereby the computational time is further increased.

References

- [1] Trebilcock, R. M., and A. J. Morris, "Methodology for Optimum Design in a Real World Environment," *Proceedings of the 1997 Conference on Optimisation in Industry*, Palm Coast, Mar. 23–27, 1997, pp. 201–206.
- [2] Eskelinen, H., "Developing Design Methodology and DFMA-Approach for Passive Microwave Mechanics," *Proc. of Nord Design 2000-Conference*, Copenhagen, Denmark, Aug. 24–25, 2000, pp. 129–138.
- [3] Lefort, L., and T. Kesavadas, "Interactive Virtual Factory for Design of a Shopfloor Using Single Cluster Analysis," *Proceedings of the 1998 IEEE International Conference on Robotics and Automation*, Part 1 (of 4), Leuven, Belgium, May 16–20, 1998, pp. 266–271.
- [4] Trethewey, K. R., et al., "Development of a Knowledge-Based System for Materials Management," *Materials and Design*, Vol. 19, No. 1–2, 1998, pp. 39–56.
- [5] Peak, R. S., et al., "Integrating Engineering Design and Analysis Using a Multi-Representation Approach," *Engineering with Computers*, Vol. 14, No. 2, 1998, pp. 93–114.
- [6] Ehrlich, J. N., and W. R. Lilegdon, "Making Better Manufacturing Decisions with AIM," *Proc. of the 1997 Winter Simulation Conference*, Atlanta, GA: Dec. 7–10, 1997, pp. 552–558.
- [7] Krishnamurthy, K., and K. H. Law, "Version Management in a CAD Paradigm," *Proc. of Computers in Engineering ASME Database Symposium 1995*, Boston, MA: Sept. 17–20, 1995, pp. 1133–1144.
- [8] Lu, S. C., et al., "Simple Visualisation Tool to Support Concurrent Engineering Design," *Computer Aided Design*, Vol. 29, No. 10, 1997, pp. 727–735.
- [9] Montau, R., and M. Flemming, "Federated Product Data Management Enables New Possibilities for Rationalisation in Engineering Design," *Konstruktion: Organ Der VDI Gesellschaft Konstruktion und Entwicklung*, Vol. 49, No. 6, 1997, pp. 36–42.
- [10] Eskelinen, H., "Improving the Performance of Mechanical Microwave Subassemblies for Telecommunication Electronics," *Proc. of the 15th International Conference on Production Research (ICPR)*, University of Limerick, Ireland, Aug. 9–13, 1999, pp. 925–928.

-
- [11] Steffen, D., "How to Quantify and Improve Mechanical Drawings," *Machine Design*, No. 6, 1992, pp. 77–79.
- [12] Suoranta, R., and H. Eskelinen, "Interaction Between Virtual Engineering and Hypermedia Applications in Selecting Heat Treatments for Welded Microwave Components," *Proc. of the IIW Asian Pacific International Congress Incorporating the WTIA & NZIWI Annual Conferences*, Melbourne, Australia, Oct. 29–Nov. 2, 2000.
- [13] Eskelinen, H., "Computer Integrated Use of CAE and Microwave Mechanics Simulation in Welded Stripline Filter Design," *Proc. of the TWI-Conference Computer Technology in Welding and Manufacturing*, Copenhagen, Denmark, Jun. 6, 2000.
- [14] Le Goff, M., and P. Pouligen, "Radar Measurements Using Ultra Wideband Short Pulses," *Proc. of Int. Conference Radar '99*, Brest, France, May 17–21, 1999, p. 6.
- [15] Lostanlen, Y., et al., "Characterisation of Clutter for Ultrawideband Radar," *Proc. of Int. Conference Radar '99*, Brest, France, May 17–21, 1999, p. 6.
- [16] Gustavsson, A., et al., "Radar Imaging of Forested Areas During the RAMCAR98, SAR Experiment," *Proc. of Int. Conference Radar '99*, Brest, France, May 17–21, 1999, p. 6.
- [17] Thaysen, J., et al., "Ultra Wideband Coplanar Waveguide Fed Spiral Antenna for Humanitarian Demining," *Proc. of Int. Conference EuMW 2000*, Paris, France, Oct. 3–5, 2000, pp. 375–378.
- [18] Duzdar, A., and G. Kompa, "A Novel Trapezoidal Antenna Fed By a Ground Image Plane and Backed by a Reflector," *Proc. of Int. Conference EuMW 2000*, Paris, France, Oct. 3–5, 2002, pp. 1–4.
- [19] *IE3D Release 7 User's Manual*, Zeland Software Inc., 1999.
- [20] Marti-Canales, J., et al., "Time Domain Antenna Measurements in Compact Ranges: Modelling and Experimental Results," *Proc. of Int. Conference AP2000*, Davos, Switzerland, Apr. 9–14, 2000.
- [21] Yarov, A., P. Aubry, and L. Lighthart, "GPR Antenna Measurements in Time Domain," 2000, *Proc of Int. Conference AP2000*, Davos, Switzerland, Apr. 9–14, 2000.
- [22] de Jongh, R., L. Hajian, and L. Lighthart, "Implementation and Operation of the Time Domain Antenna Measurement Technique," *Proc. of Int. Conference AMTA '97*, Boston, MA, 1997, p. 5.

5

Instructions for Technical Documentation and Dimensioning

It is obviously not reasonable to try to collect all the instructions for technical documentation or “technical drawing” in this book. We feel that it is important, however, to emphasize those guidelines that are specially needed in microwave mechanics and which differ significantly from traditional documentation practices. The main areas are the following:

- Effects on parametric modeling;
- Difficulties of applying rules of DFMA;
- Restrictions in utilizing general tolerances.

For practical technical drawing work, however, the following minor tips might turn out to be useful:

- Typical passive microwave constructions consist of several materials. We recommend that the sheared areas in drawings are marked with specified hatching symbols for each individual material.
- Many additional components are originally dimensioned using U.S. inch scaling. We suggest that these values are written in inches and also in millimeters in parenthesis (coaxial connector mounting dimensions and waveguide flanges are typical examples).

- Some special tooling might be needed to ensure sharp edged geometries, for example, or specified surface properties. We recommend that full instructions are written with complete sentences near the title block of the drawing, instead of using symbols with special marks.
- The suitable manufacturing technology might differ from the commonly used one. We recommend that this be highlighted in a note with a reference arrow near the geometry.
- Many commercial trademarks are used for microwave materials. We suggest that either the standardized material identification number or detailed table of chemical composition of the material is presented in the drawing as well. This data is needed for planning (e.g., welding procedures or heat treatments).
- Some special requirements may be set for welded joints. We suggest that a welding process specification sheet (WPS) is filled out to show these requirements.
- Requirements for geometrical tolerances might differ slightly from the most common ones used in engineering. We recommend that instructions for desired measurements are attached to the drawings.
- The so-called maximum material principle should be avoided when defining tolerances for high-performance microwave devices.
- It is often more important to ensure the shape of the surface than the ultimate value of surface roughness.

5.1 The Relationship Between RF Parameters and Mechanical Parameters

The term “parametric modeling” means that during the design procedure it is possible to compose new products by using scale factors for the dimensions of the new product. In the ideal case, the scale factor is equal in all coordinate axes. If this is the situation, it is easy to compose new product variants in the 3-D environment. Significant time can also be saved, however, if parametric modeling is possible in one or two directions. One typical example in microwave mechanics is low loss filters, which will be presented in detail in this book later. For example, the air gap between the center conductor and the bottom (and the cover) of the filter has a parametric relationship with the thickness of the conductor. On the other hand, the dimensions of the center conductor have a parametric relationship with the operating frequency. This

example shows illustratively the two possibilities of utilizing parametric modeling in designing a mechanical microwave component:

- Performance-oriented parametric modeling;
- Manufacturability-oriented parametric design.

The aspect of manufacturability comes from the fact that, while the scaling factor for specific dimensions is changed, it also sets new requirements for the possible manufacturing technologies. For the filter, for example, this means that as long as the thickness of the center conductor is larger than 3 mm, it is reasonable to use machined components. If the thickness is less than 3 mm, sheet metal processing becomes more attractive. This causes problems in many cases. It is relatively easy for the designer just to change the scale factors. Then the model seems to be ready on the computer screen for either milled or sheet metal processed products. The instructions for manufacturing, however, will have significant differences.

Another important aspect for parametric modeling in microwave mechanics comes up during the design of screw joints. This happens in constructions, which have tight RF sealing requirements (e.g., due to the desired noise or loss level). The rule of thumb is that the distance between the mounting screws should not be longer than $\lambda/32$. This value is easy to calculate and it could be set as a parameter for the CAD program. The position of each mounting hole in the construction (e.g., in a filter body) could be automatically defined. Unfortunately, things are not so simple. For performance-oriented design, it would be better if the mounting screws were placed as near as possible to the short circuiting point of each resonator rod. The distances between the rods, typically, are not constant. On the other hand, there are some pure geometrical limits that make it impossible to use parametric distances between the mounting holes. Either the minimum edge distance might set limits, or possible inlets or feedthrough connectors, for example, might disturb the spacing.

There is also, to certain extent, a relationship between the required surface roughness of a microwave component and its performance. Typical examples are filters and cavity resonators. If we want to have a high-Q filter or another product with very low losses, the maximum allowed surface roughness can be estimated simply from the operating frequency (e.g., for 300 GHz the recommended R_a might be $1.6 \mu\text{m}$). A brief guide for selecting the requirement from the standard values as a function of carrier frequency is given in Table 5.1.

Table 5.1
The Relationship Between Frequency Range and
Surface Roughness in Some Radio Frequency Components

Frequency (GHz)	Surface Roughness	Tolerance Grade
300–600	0.8 μm	IT5
150–300	1.6 μm	IT6
75–150	3.2 μm	IT7
35–75	6.4 μm	IT8
15–35	12.8 μm	IT9–10

Because the operating frequency and performance requirements of a radio frequency component are vital details, when checking the drawings (especially tolerance and surface requirements), it is important that each document includes at least the following additional data in the title block:

- Operating frequency (or wavelength);
- Sealing requirements (if essential).

We have included a number of illustrative examples of all these cases on the attached CD-ROM. Both milled and sheet metal processed filter constructions are presented, and detailed dimensioning for each product and component is given.

5.2 Differences Between DFMA- and Performance-Oriented Approaches

Table 5.2 includes the most common rules for DFMA-oriented design and the exceptions that usually occur when dealing with passive, mechanical microwave components.

For many engineering workshops it seems to be hard to understand that the functional and performance oriented aspects are so important in microwave mechanics that it is impossible to follow the rules of DFMA word by word. In traditional mechanical engineering, the manufacturers usually complain that the designers do not know enough about manufacturing

Table 5.2
Problems with Utilizing DFMA-Oriented Design in Microwave Mechanics

Rules for DFMA	Exceptions in Microwave Mechanics
1. Minimize the number of parts	Typically there is a need to use striplines and cables, for example, in the same construction which usually makes it necessary to use several connector types.
2. Design modular constructions	Most of the connectors and electrical components are of standardized sizes that set limits to the free design of a modular geometry for the passive mechanical body.
3. Avoid extra joining components	Many of the standardized parts already include a screw assembly!
4. Minimize the number of necessary manufacturing stages	In microwave applications, the range of various types of materials and geometries is so wide that we need technologies ranging from traditional machining and welding to specialized electroforming processes!
5. Check that there is enough space for assembly and necessary tools	In many cases the performance can be improved (e.g., lower loss) if distances between components can be minimized.
6. Use standardized tools	In many cases, desired propagation modes of microwaves are ensured by using geometrically "ideal" shapes of cavities or profiles. Unfortunately, the manufacturing stages for these geometries require specialized tooling systems.
7. Design the construction so that all the parts can be assembled from the same direction	Usually the rules are set according to microwave propagation and not for easy assembly.
8. Use appropriate general tolerances	In many cases the values of general tolerances are not sufficient.

From: [1].

technologies. This is partly true for microwave components as well, but there are good reasons to ask if all manufactures are aware of the related quality requirements.

There are some promising ways, however, to utilize DFMA aspects in microwave design as well. In Table 5.3 we present the general DFMA rules and their applications for passive radio frequency devices.

Table 5.3
Possibilities for Applying the DFMA Approach in Microwave Mechanics

Rules for DFMA	Possibilities for Applying in Microwave Designs
1. Try to avoid strict manufacturing tolerances whenever it is possible.	Use of flexible cables decreases the need of assembly tolerances.
2. Try to repeat same manufacturing stages. Think of each stage as a "module"	Use of same welding processes with same material pairs. The process parameters compose a "module."
3. Utilize parametric modeling in design	If the product is modeled parametrically, the data for CAM is also produced parametrically. (e.g., operating frequency can be used for parametric scaling).
4. Compare alternative manufacturing technologies and choose the easiest one that ensures the required quality.	For example, in cutting sheet metal parts, it is in some cases better to use pulsed Nd:YAG lasers than CO ₂ lasers or water jet cutting.

5.3 On the Suitability of General Manufacturing Tolerances for MW Mechanics

Instead of setting specified tolerance requirements for dimensions, form, location, orientation, or runout of a geometry, it is possible to utilize so-called general tolerances. General tolerances are divided into two main classes as follows:

Class 1:

- Geometrical tolerances for features without individual tolerance indications;
- General tolerances for linear and angular dimensions without individual tolerance indications.

Class 2:

- Stamped steel parts, general tolerances;

- Welding and associated processes, quality classification, and dimensional tolerances of thermally cut surfaces;
- Welding, general tolerances for welded constructions, dimensions for lengths and angles, and shape and position;
- Casting, system of dimensional tolerances.

All of these standards are agreed upon and followed internationally [either Euronorm (EN), International Standardization Organization (ISO), or DIN standards], which gives good possibilities of applying them in mechanical engineering. They are basically written to help the designer during the documentation. If he is able to use one or several of these standards, the work of writing individual tolerances will be decreased significantly. The idea in using these standards is simply to put one indication into the title block of the drawing and, in the ideal case, no other markings will be necessary.

In the first class of the standards, the allowed deviations are printed in tables according to specified size ranges. In general, the larger the size is, the larger the allowed deviation is. The allowed tolerances are given in the form of original size tolerance value. Unfortunately, these two facts are usually the reasons why general tolerances are hard to utilize in microwave work. In most cases, the allowed deviation is set to be either “+ value” or “– value” from the ideal dimension not of type “value.” It has also been proven that, in microwave mechanics, the required tolerances are, in many cases, too strict to fit between the values of general tolerances. In practical engineering shop work, it could sometimes cause problems if only general tolerances are used. This actually means that there should always be a data sheet in use from which the tolerance identifications could be “translated” into real maximum and minimum deviations.

The general tolerances in the second class are basically made according to the same principles as the ones in class 1. Because the types of manufacturing errors are known, it is reasonable to set tolerance values for specific manufacturing faults. In welding, for example, it is typical that, due to heat input, the workpiece tends to twist or bend and the maximum values can be estimated. Or after casting, it is possible to estimate the surface roughness and measure the shrinkage. These types of values give a good possibility of classifying manufacturing quality into a number of groups. If the quality is acceptable according to one of these standard groups, only the name of this group needs to be mentioned in the title block of the drawing.

The same problems will occur in practical work as occurred in the general tolerances from class 1. For mechanical microwave components, the main problem is, however, that the general tolerances are usually quite far from the desired quality. One exception is relatively heavy welded constructions, which are used as body structures in microwave measuring systems. In some of these applications the general tolerances for welding and also related technologies have been used successfully. A typical example of a wood measuring system [2, 3] is shown on the attached CD-ROM. Detailed tolerance indications are presented together with the appropriate use of general tolerances.

For further information, the numbers of international standards are presented in Table 5.4.

Table 5.4
Standards of General Tolerances

General Tolerances	Standard
Geometrical tolerances	EN 22768-2 ISO 2768-2
Linear and angular dimensions	EN 22768-1 ISO 2768-1
Stamped steel parts	DIN 6930 / 2
Welding and allied processes	EN ISO 9013
Welding	EN ISO 13920
Casting	ISO 8062

References

- [1] Eskelinen, H., *Tuning the Design Procedures for Laser Processed Microwave Mechanics*, LUT: Acta Universitatis Lappeenrantaensis 87, 1999.
- [2] Eskelinen, P., and P. Harju, "Characterizing Wood by Microwaves," *IEEE Aerospace and Electronics Systems Magazine*, Vol. 12, No. 2, 1998, pp. 34–35.
- [3] Eskelinen, P., et al., "A Microwave System for The Analysis of Trees and Logs," *Proc. MIOP 2001*, Stuttgart, Germany, 2001, pp. 182–185.

6

Effects of Production Volume and Related Topics

6.1 General Aspects Related to the Evaluation of Production Costs

In general, there are four main cost elements that should be taken into account when evaluating the total costs of a microwave product:

1. Design costs;
2. Material costs;
3. Manufacturing costs;
4. Costs spanning the lifetime of the product.

Let us try to find some of the special aspects in microwave mechanics dealing with each of these items.

6.1.1 Design Costs

Many microwave applications include difficult geometries or materials regarding traditional manufacturing processes (e.g., turning, milling, or casting). It is obvious that much time is needed to further develop the first prototypes to be suitable for production. To avoid redesigns, quite detailed instructions are necessary. The design costs of a microwave component can

be estimated to be at least double those of any “non-high-tech” product. Decisions made during the design phase cause roughly 80% of the costs during the following (manufacturing) stages. This means that time and money “saved” during design usually must be repaid later. The worst mistake that is usually made is to forget to gather and compare different material, construction, and manufacturing possibilities during the early steps of design work.

6.1.2 Material Costs

Passive microwave devices utilize several precious and expensive materials. Gold, silver, or some specially mixed powders are needed, for example. It is also common that an extremely good quality grade of alloyed metals is used in microwave applications and the price is therefore also higher. If expensive materials are used, their price is, of course, essential. Additionally, some of these materials are difficult to use in traditional manufacturing processes or some special arrangements are needed, at least, during production. This doubles the effects of material selection on the price. A direct comparison between a microwave application and “non-high-tech” product is hard to make, but typically material costs are at least 10 times higher.

6.1.3 Manufacturing Costs

Differences between various manufacturing technologies are presented later in this chapter. In general, microwave applications need specialized tooling and fixturing systems and, in some applications (depending mostly of the operating frequency), quite tight dimensional tolerances down to 1 μm . These call for some extra time to make a dedicated set-up in the production system. Although the manufacturing stages themselves could be quite cost effective, the long set-up times and specialized tools and fixturings increase production costs by about 500 to 800% in prototyping or small series production. In high volume production, these cost elements are marginal. There are several commercial semiproducts or half-finished materials (e.g., cold drawn waveguide profiles, flanges, or coated raw materials) that could be reasonable alternatives to an in-house start from scratch. The principles are as usual for handling tooling costs, fixed costs, capital costs, labor costs, and indirect labor costs. The main actions should be focused on decreasing the lead-time—that is, to minimizing the time required to start production.

6.1.4 Costs Related to the Expected Lifetime of the Product

In some cases microwave components should also withstand, for example, environmental loads. This is a good reason to compare different materials

and their lifetimes. The classic comparison is typically made between two alternatives:

1. Common base materials with an appropriate coating, a relatively short lifetime, the product must be changed due to a break-through in the coated surface, relatively cheap;
2. Specialized base materials, a long lifetime, no changes needed during the lifetime, extremely expensive.

A good piece of advice is to try to compose a ratio or a characteristic that shows the price in the form of a “unit,” such as [performance/price/lifetime].

6.2 Relationship Between Manufacturing Costs and Surface Finish

Figure 6.1 presents the relationship between relative manufacturing costs and surface roughness, which is achieved by some common manufacturing technologies. If we had added more curves for alternative technologies, their shape would be the same: After the specified surface roughness level, the costs will increase exponentially. In milling and turning, the limit is generally $0.8 \mu\text{m}$ and in grinding $0.4 \mu\text{m}$. A better surface finish rapidly adds costs.

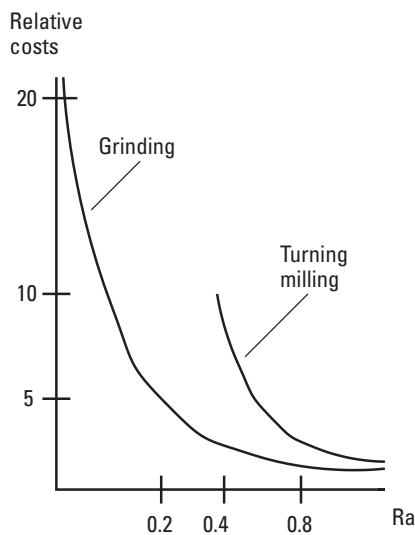

Figure 6.1 Relationship between relative manufacturing costs and surface roughness.

6.3 Relationship Between Manufacturing Costs and Dimensional Tolerance

Regardless of technology, as long the dimensional accuracy is met with a standardized process, the costs depend only on the manufacturing time. If there is a need to change the process to ensure better accuracy or dimensional tolerances, the price immediately rises, essentially as presented in Figure 6.2. This is easy to understand because usually some new set-ups are needed and new measurements are necessary to ensure the quality.

6.4 Design for Manufacturability

Design for manufacturability includes:

1. Methods for choosing the most appropriate construction of an item for production;

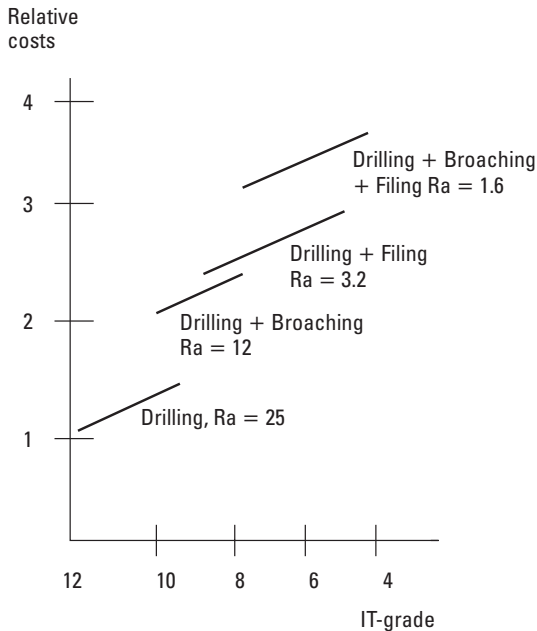

Figure 6.2 Relationship between relative manufacturing costs and required dimensional tolerances (IT-grade).

2. Instructions or rules to design the product for easy manufacturing;
3. Means to improve cooperation and integration between design and manufacturing.

In addition to DFM, DFMA underlines the importance of assembly stages in production. In some cases assembly is regarded as one manufacturing method and could therefore be included in DFM. In order to differentiate between, for example, the different joining stages and the stages of workpiece positioning during assembly, the term DFMA might be needed. Both terms emphasize the fact that the designer is responsible for taking into account the manufacturability aspects. Manufacturability aspects should not pop up later as redesign stages due to critical feedback from the manufacturer.

6.4.1 Goals of DFM/DFMA

The goals of DFM/DFMA are to improve the integration between design and manufacturing, to reduce product development time and costs, to improve product quality and reliability, to shorten lead time, to increase productivity, and to respond more quickly to customer requirements.

From the designer's point of view the basic tools to achieve these goals are the use of modular constructions, standardization, minimizing the number of parts in construction and, for example, designing the assembly so that it is possible from one direction only. On the other hand, from the manufacturer's point of view, the tools to achieve the goals of DFM/DFMA are the development of more flexible manufacturing systems, the utilization of automation, the use of multiprocessing systems and the development of flexible fixturing systems.

6.4.2 The Barrier Between Designing and Manufacturing

The wall or the gap between designers and manufacturing plants builds up, basically, for three reasons. First, the designer tries to utilize modular constructions and standardization, but he might do this by taking into account only the functional modules of the construction. The designer keeps the manufacturing modules in the background. On the other hand, the manufacturer wants to improve the equipment used for production and enhance its efficiency. He suggests changes to ensure the flexibility of the manufacturing process. These changes, however, are made from the equipment's (or tool's) point of view but not from the point of view of the product or production.

Yet another reason can be found from organizational arrangements. Many researchers have suggested groupwork, teamwork, or crosstechnological approaches. They want to improve the interaction between design and manufacturing to achieve the advantages of DFM/DFMA. It is also essential to ensure that the design engineers of mechanical microwave devices gain enough knowledge about manufacturing during their university studies. Today, it seems that almost all of the time is used to teach methodologies and the use of computer-aided means. The third reason is the fact that a product is designed in one part of the world, while pieces are often manufactured on another continent, assembly happens somewhere else, and finally marketing (with various minor customization changes) is global. The variety of possible combinations complicates the cooperation.

As a matter of fact, DFM/DFMA is developed to break down the wall between design and manufacturing (see Figure 6.3). Computer-aided DFM

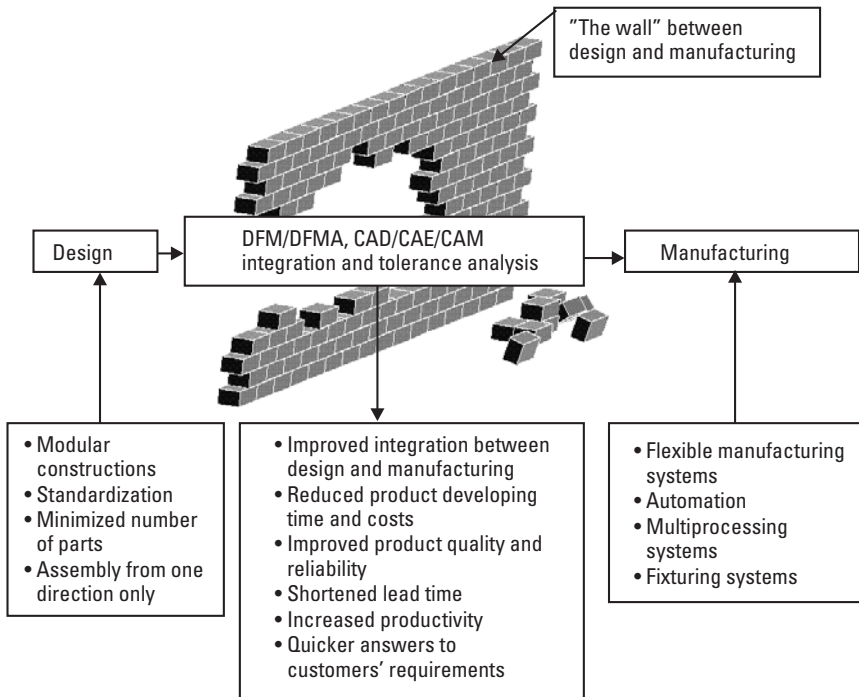

Figure 6.3 Even though both design and manufacturing have their own tools to improve manufacturability we suggest the use of computer-aided DFM/DFMA to break "the wall." This ensures that the benefits of DFM/DFMA can be achieved [1].

can be briefly described as a design environment which enables the identification of potential manufacturing problems and provides suggestions to eliminate them. The use of computer-aided means makes it possible for the designer and the manufacturer to work in parallel. The DFM approach assumes that incorporating manufacturing issues into the design process is not a serial decision method but has multiple parallel interactions, from the origination of a conceptual design to direct linkage with manufacturing parameters.

The most important, practical, computer-aided connection between design and manufacturing is the possibility to transfer (without any additional operations) CAD geometries in DXF or stereo lithography file format (STL) format to CAM or rapid prototyping (RP) software. For example, the geometry of laser-cut plates and machined jigs of the filter construction to be presented later in this book were directly saved in the required format during the design stage. It is still regrettable, however, that many additional CAE software packages used with AutoCAD software cause errors when trying to save files correctly in DXF or STL format. Commercial software packages do not support the automatic coupling of electromagnetic simulation results with the mechanical construction files. Another important application of CAE tools in microwave work is the 3-D modeling of each device to ensure the possibilities of assembly.

6.4.3 Putting DFM in Practice

The basic steps to carry out DFM are as follows:

- Minimize the number of parts in a construction.
- Design modular constructions.
- Try to find as many functions for a part as possible.
- Avoid additional components just for joining other parts.
- Design the construction so that all the parts can be assembled from the same direction.
- Minimize the number of different manufacturing methods and stages to be used.
- Obey the rules of easy manufacturing for each manufacturing method (applied to your own production facilities).
- Check that there is enough space for necessary tools during assembly, for fixturing systems during manufacturing, and for a robotic gripper in automated systems.

- Use standardized geometries, tools, and components.
- Check the machining allowances.
- Check the suitability of the material for the manufacturing methods.
- Use appropriate general tolerances for your own production.
- Check the cumulative assembly errors and design a safe place for manufacturing errors in the construction.
- Check that the values of surface roughness, tolerances for linear and angular dimensions, and geometrical tolerances are mutually adjusted.
- Use parts that can be assembled from several directions and still function perfectly (avoid parts which are easily assembled in a wrong position or which function only in one position).
- If there are several possible manufacturing methods, choose the one that needs the fewest preparations.
- Try to repeat the same manufacturing stages, think of each manufacturing stage as a module.
- Use parametric design.
- Design the device directly for automated production (in most cases this will be extremely suitable for manual production too).
- If manual production is used, check the ergonomic aspects.

It is still difficult to simultaneously satisfy all the requirements if the traditional systematic design approach, for example according to VDI 2221 [2], is used. In the systematic design approach, it is typical that the functional design of a product and its modular construction are followed by the documentation for manufacturing and assembly. Because these two stages are not parallel, or are usually presented as consecutive in flowcharts at least, it is possible that the designer does not give enough attention to manufacturing aspects during modularization.

Another problem from the designer's point of view is the large amount of subjective information about different manufacturing methods. For example, laser welding seems to have only limited real advantages in passive microwave devices due to its generally low heat input or minimal postprocessing needs. The coming chapters will demonstrate, for example, applications where both the heat input and the inadequate cut or weld surface quality have caused additional manufacturing stages and therefore problems for DFM.

Traditionally, both passive and active microwave components require the use of tightly closed and, usually, machined enclosures, which has meant screw joints placed at about $\lambda/32$ intervals. Here, the application of DFMA really gives a relief to the tedious assembly task. It can also be used for appropriate tolerance analysis and modular design.

6.4.4 Additional Tools for DFM

6.4.4.1 Virtual Prototyping and Manufacturing

One large problem in the modern cost-conscious electronic industry is to fit either more and more miniature electric components, or relatively (compared with the electric components) large mechanical components into the same construction. It is possible to find a solution to this problem by virtual prototyping and manufacturing (VM). It is suitable for the designed circuits and necessary mechanical constructions, their environmental conditions, and certain manufacturing processes. Simulations are much less expensive and much more comprehensive than tests with physical prototypes. VM can detect and help correct design and manufacturing problems more thoroughly than physical prototypes through a highly accurate numerical analysis and an integrated design system.

6.4.4.2 Integrated Product Teams

One effective tool to improve the possibilities of DFM is the use of integrated product teams (IPT). Typically their purpose is to achieve low manufacturing costs while maintaining the required quality level. Our observations highly support the need of material knowledge in design teams. The various electrical components used in microwave mechanics include multiple materials, for example, in connectors (PTFE-insulators and gold plated copper-beryllium pins, while the body is made of steel alloy). Also the materials used in circuits, circuit boards, and cables are far from the traditional materials in mechanical engineering. On the other hand, the case devices presented in this book have indicated a need for enhanced precision in producing copper or aluminum parts with lasers.

6.4.4.3 Fuzzy Logic

During the few last years, the use of fuzzy logic has also become common in solving the problems of mechanical engineering. Fuzzy cognitive maps are employed to develop the design framework. In this case, the framework is built to couple the design features with manufacturing constraints.

Fuzzy logic is a superset of conventional Boolean logic that has been extended to handle the concept of partial truth—truth values between “completely true” and “completely false.” It was introduced in the 1960s as a means to model the uncertainty of natural language. It has been said that, rather than regarding fuzzy theory as a single theory, one should regard the process of “fuzzification” as a methodology to generalize any specific theory from a discrete to a continuous (fuzzy) form. Most applications of fuzzy logic use it as the underlying logic system for fuzzy expert systems. A fuzzy expert system uses a collection of fuzzy membership functions and rules, instead of Boolean logic, to reason about data. Fuzzy expert systems are used in several wide-ranging fields, including linear and nonlinear control, pattern recognition, operation research, and data analysis.

6.4.4.4 Reverse Engineering

Reverse engineering (RE) is an approach that utilizes an existing physical part and in which the geometry of this part is digitized into a 3-D CAD format. It does not have here the negative flavor, which we may find within the semiconductor or software enterprises (as a synonym for espionage). This approach is useful in cases where old products are redesigned, current products are modified, design for reuse is needed, or for overseas product design. In these cases, it is assumed that either no CAD data is available, or only part of that data can be directly utilized. A powerful tool to enlarge the possibilities of RE is the use of rapid prototyping. It is also possible to enlarge the computer-aided environment to include modules for manufacturability analysis. Due to the basis of RE, it is probably not the most suitable approach for designing totally new products. In microwave mechanics, however, it is possible to use scale models or coated models (with a body made of some easy-to-form material), the geometry of which can be transferred to a CAD application through the means of RE. On the other hand, in microwave mechanics there are often situations where the documentation for European and American markets differ from each other. RE could be one possibility for completing this information.

6.4.5 More Effective Use of DFM

The following practices have been found to make DFM more effective:

1. DFM should start from the beginning of the design process. If DFM is placed as a consecutive design stage after physical, electrical, and geometrical designs it will usually fail.

2. Even though computer-aided means, VE, and fuzzy logic are all fine for DFM, nice results can be achieved with just manual questionnaires if they are tuned for each manufacturing method. They should be included in the design methodology. 3-D CAD modeling, however, is useful for checking the assembly, and CAD/CAM integration should be prepared by using, for example, DXF and STL format data files.
3. The suitable manufacturing method(s) should be recognized as early as possible to ensure that DFM aspects can be utilized without redesigns.
4. The fasteners or fixturing systems should be designed simultaneously with the product or, if possible, standardized fixturing systems should be utilized. This task should not be left alone to the manufacturer. The meaning of fastener design can be regarded as an aspect of quality control or it can be a part of the method where any preprocesses are evaluated before manufacturing.
5. The designer should have a good knowledge of the possibilities of different manufacturing technologies and the design rules related to them. Teamwork is recommended and experts of design, manufacturing technology, and material selection are needed.

6.5 A Cross-Technological Approach

The design engineer meets different areas of science, different human views, various industrial goals, and many philosophical, psychological, social, or sociopolitical opinions. This constantly changing environment can be seen as a disturbing factor against design work, but it should be preferably regarded as a source for new ideas and innovations. The environment must be turned from an annoying element into a supporting factor.

In microwave applications, the tightest cross-technological connections should be between mechanical engineering (including design and manufacturing), microwave mechanics, electronics, and computer-aided means (see Figure 6.4).

To maximize the possible advantages coming from this cross-technological approach, the following task list for the designer has been produced:

1. The most important cross-technological connections should be clarified in the beginning of a design project (see Figure 6.4).

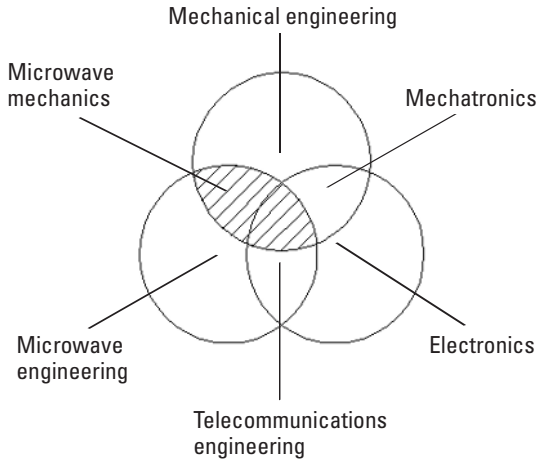

Figure 6.4 The tightest cross-technological connections for the topic are shown as a hatched area [3]. The word “mechatronics” has been used to describe the rapidly increasing tendency to combine mechanical technology with electronics and computer control to enhance the performance and flexibility of products and manufacturing equipment.

2. The team members (experts) for the design work should be gathered from the main cross-technological areas as demonstrated in Figure 6.4. During the design phases of the products to be presented in the coming chapters, for example, we had an expert of engineering design, a microwave specialist, one for manufacturing technology, and yet another scientist for laser processing.
3. The use of integrated, computer-aided means can be a powerful tool to combine the cross-technological areas. The product data management systems (PDMS) are formulated to handle all the life cycle information in the same computer-aided environment, which is enlarged with the use of databases, by networking, and with rapid prototyping.
4. The product specifications must also include the aspects of ergonomic, recycling, and environmental protection if applicable. These requirements must be established in the beginning of the design and not afterwards.
5. Different fields and areas of science can be used as sources for ideas and innovations. The individual designer must be encouraged to utilize these sources.

6. The more complicated the product to be designed is, the greater the benefits obtained by using a cross-technological approach. In the most primitive cases, however, this might be superfluous.

6.6 Concurrent Engineering Design

Concurrent engineering design (CE design) is a term that formally describes a set of technical, business, manufacturing planning, and design processes that are concurrently performed by elements of the manufacturing organization. The CE design process, in its simplest form, is the integrated execution of four businesses and technical processes at the same time. These processes are:

1. Process management;
2. Design;
3. Manufacturability care;
4. Automated infrastructure support.

There are at least three different terms in the literature that are meant to refer to same subject: concurrent engineering (CE), simultaneous engineering (SE) and parallel engineering. The term “integrated product development” is also used sometimes.

The main purposes of CE are the reduction of development time and costs, an improvement of quality, and the enhancement of competitiveness. Scientists have no common view of the most important aspects of CE, and this leads to different emphases in the treatment of the topic. At least the following aspects have been underlined in the recent literature:

- Importance of process management [4];
- Importance of production management issues [5];
- Need of life cycle analysis (LCC) to support designers’ decision-making process [6];
- Use of quality-oriented decision making during CE process [7];
- Lack of methods supporting the planning of production systems when using CE [8];
- Improper understanding of how to tailor the concept to suit different circumstances (e.g., in various kinds of companies) [9];

- Importance of the human, organizational, and social aspects in the working team (Duffy and Salvendy) [10].

As the previous list proves, there are contradictions in the various scientists' views regarding the direction of the development of CE and its main disadvantages. Most of the researchers, however, still believe in the possibilities for CE to improve productivity and cost-effective design. Instead of fighting over who is right, it is probably better to consider what we could learn from each different opinion.

6.6.1 The Design Process for CE

Before presenting an approach of CE design, let us first express some criticism of traditional design processes. The most common design approach that could be called "step-wise refinement" is good for inexperienced designers, and produces gradually improving designs. Its primary disadvantage, however, is that it tends to have a result which comes from compromises as the process proceeds. It is also difficult to execute many of its small steps concurrently. Concurrency is achieved only by considering variants through the design and manufacturability stages simultaneously. This evaluation of multiple variants speeds up the process, but creates waste when surplus variants are eliminated. In addition, some components cannot be designed until others are complete. Unfortunately, the decision to go back to an earlier design step is usually encountered late in the process, and an expensive, time-consuming restart is required. Since restart is avoided if possible, an average or even worse quality of design is usually the result.

Adding work breakdown structures (WBS) to the step-wise refinement improves output and gives an order to the complex product design process. WBSs organize by using a differentiation technique. The product is broken down in detail. Meanwhile, different teams are assigned to various product components.

6.6.1.1 Group Technology

Generally, group technology (GT) is a technique used to classify previous designs using product or component features, performance attributes, and characteristics. In this way, previous designs can be easily identified and derived. Once a generally applicable design is found, a derivative can be developed. This happens by reusing existing information and by modifying it to achieve the end product quicker and with less costs. Miller [4] thinks that if a new idea is required, GT may not be useful. So-called parameterization is

a combination of GT and the stepwise refinement design approaches with an additional element. This parameterization works only in cases where most of the design problems can be stated as a set of relational values.

6.6.1.2 Collaborative Concurrent Design

So-called collaborative-concurrent design is an effective process for CE design. It uses a holistic basis. Manufacturability, production planning, and incorporation are not added steps, but an integral part of the process. In collaborative-concurrent design, the fully designed end-product (construction) comes out simultaneously. Design variants can be considered quickly, and the cycle-time, costs, and quality disadvantages of a stepwise refinement can be largely avoided. There are two drawbacks in this approach. First, because the full end-product is designed simultaneously, a holistic design sometimes gives a perfect result and sometimes the result must be completely discarded. Secondly, it is difficult for the management to understand the status, schedule, and budget when the final result is an all-at-once deliverable.

After having followed this conversation about the possible improvements of CE, it seems that the MW-engineering design phase should be especially considered for improvements.

In the following chapters, we will present some practical applications of concurrent engineering where the task was to design fixturings for laser processed mechanical microwave parts. The same 3-D CAD models can be utilized during both design phases and furthermore for beam control when programming the beam or workpiece movements.

6.6.2 Manufacturability for CE Design

Manufacturability can be regarded as a special process within CE design. It is focused on the transition of the product and process design towards total production management. This particular change in perspective has created the “wall” between designers and the rest of the complex modern manufacturing organization. Teaming is an important element of CE design and becomes particularly important in discussions of manufacturability. The various areas of production affected by different design aspects are indicated as members of the CE dimension of the CE design team. The simultaneous interest of design and manufacturability makes up the CE design. The transition from design to manufacturability is also reflected in the interaction of different CE design intellectual activities. As the initial product outlines, general specifications, and component strategies are developed during conceptualization, production planning begins. As more details come up in

visualization, more detailed product and component production scheduling, material acquisition, and other details of planning are conducted.

The idea of teaming, CAD integration and VE has been tested on a minor scale for the selected microwave devices during their design and manufacturing processes (which are presented in this book). It proved to be effective in those cases where the design group consisted of experts on electronics, engineering design, sheet metal work, and laser processing. All the microwave mechanics and associated components, jigs, and fixturings to be presented in this book have been 3-D modeled to ensure both the functional and geometrical requirements as well the manufacturability aspects. The needed improvements for laser processing were especially easy to obtain by using 3-D modeling during the early stages of design process.

6.7 Manufacturing Costs of Prototypes

The development process of many technology products normally includes several prototype phases and tests before the final design. Unfortunately, these prototypes can constitute the largest portion of the total developing costs. To minimize the costs of a prototype, several manufacturing technologies have been tried:

- The prototype is made of some soft materials like foam or plastic by using simple milling or turning operations.
- The prototype is manufactured by casting, but the mold and the casting model are made of some cheap material.
- Scale models are utilized.
- Rapid prototyping is used (the geometry of the component is laser sintered according to the computer-aided model).

One serious problem here is that if the prototype is not manufactured with the final manufacturing technology it is obvious that at least some of the geometrical limits are compromised. There are important rules, for example, for designing a product for casting or powder metallurgy, which are not necessary if the prototype is manufactured by milling or turning. In practice, this means a redesign for final manufacturing, which increases cost. Additionally, the surface quality or dimensional tolerances may well have a very weak basis if the prototyping scheme relies on a completely different technology.

6.8 Quality Aspects

Many microwave applications tend to lead to overestimated dimensional accuracies. The surface requirements may be set too tight to ensure the product's performance, though an easier way might have been, for example, to change more reliable connectors to the device. The most important thing is to compose the requirements of dimensional accuracy and surface finish from the operating frequency of the device. If the well-polished and accurate geometry proves to be insignificant for the performance of the product we have actually produced "quality" for which nobody wants to pay. A very typical curve to show the relationship between the costs and quality is presented in Figure 6.5.

6.9 Cost Evaluation by Utilizing Parametric Component Design

There are several mechanical microwave devices where the dimensions can be derived from one basic geometry by using parametric modeling. Various filter constructions, for example, or antennas for a specific frequency range are scaled easily. This fact also gives an excellent opportunity to use so-called

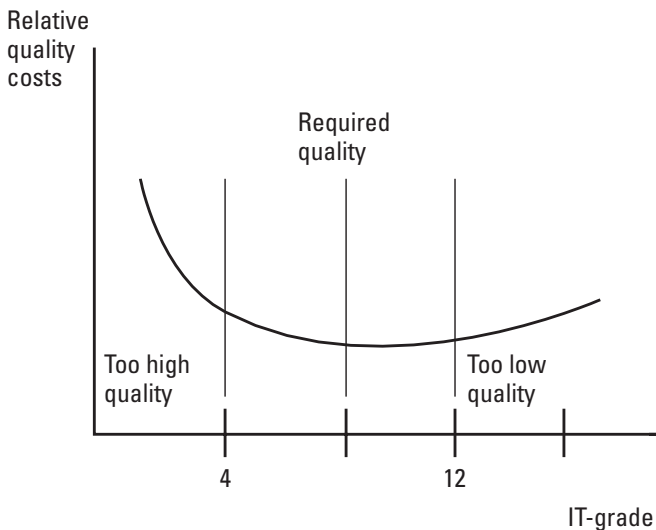

Figure 6.5 Relationship between costs and production quality (illustrated with IT-grade). Of course nobody wants to make refuse but who is ready to pay for over-quality?

similarity laws to estimate cost accumulation. Probably the most common equation is

$$\varphi_{PC} = a_3 \times \varphi_D^{x_3} + a_2 \times \varphi_D^{x_2} + a_1 \times \varphi_D^{x_1} + a_0/\varphi \quad (6.1)$$

Where

a_0 = the constant portion of total costs not depending of the product or production type

$a_1...a_3$ = coefficient describing the percentage portion of the total costs of the original product

$x_3...x_1$ = exponent describing the importance of each cost portion (see examples from Table 6.1)

φ_z = ratio between the new and original number of products to be manufactured

φ_D = scale factor describing the dimensional changes according to the similarity laws, derived from the change of the operating frequency of the device

φ_{PC} = scale factor for the production costs compared with the original product

6.10 Cost Accumulation in Laser Processed Components

Let us use laser processing as a case example for estimating production cost accumulation in MW mechanics. There is no easy or simplified answer to the question of whether laser processing is cost effective compared with other manufacturing methods or not. Only the very detailed analysis, which includes both the properties of the laser system solution and the workpiece

Table 6.1
Examples of Different Production Cost Portions Classified
According to the Value of Exponents $x_3...x_1$

$x_3 = 3$	$x_2 = 2$	$x_1 = 1$
Annealing, sand-blasting	Tuning, sawing, grinding, MIG/MAG-welding, painting	Threading, drilling, milling, assembly

requirements together with the estimated production volume, will give the approximate total costs in this restricted case. It is also necessary to analyze and sort out the cost accumulation for three different types of products:

1. New products;
2. Redesigned products;
3. Unique products (which can be manufactured only by laser).

There are examples of microwave products falling into each category. For example, some components of mobile phones can be placed in category 1 or 2 and those of space technology into category 3. The principal extra costs and assumed benefits of laser processing are show in Table 6.2.

The main cost accumulation sources of a laser processed product are:

1. The design or redesign costs;
2. Investment costs;
3. Operating costs;
4. Programming costs;
5. Costs of fixturing and workpiece manipulator systems;

Table 6.2

Extra Costs and Benefits of Laser Processing

Extra Costs of Laser Processing	Economical Benefits of Laser Processing
Energy costs to operate the system	Costs of material wastage and scrap are lower than in other manufacturing methods
The costs of supplies (replacement optics and gases)	Cost of postprocessing is lower than in other manufacturing methods
The costs of fixturing	Improvement of operating speed
The costs of preprocessing	Improvement of productivity
New, well-educated labor force is needed (including indirect labor costs)	Less labor is needed for conventional work (including indirect labor costs)
The costs of safety equipment and protective enclosures	Less rework is needed due to better quality
The costs of service and maintenance	Savings in tool wear costs Savings in maintenance costs

6. Costs of the first manufacturing tests of the new application;
7. Service and maintenance costs.

Cost areas 2 and partly 7 can be replaced with leasing costs. No more than 5 years ago, it was still quite common that the comparison between laser processing and other manufacturing methods was tried only on the basis of the change of manufacturing method of some details of the product. Typically these comparisons led to results showing that laser processing cannot be cost effective. Today it is obvious that, to achieve all the benefits that lasers can offer, it is necessary to tune the whole design and manufacturing process. On the other hand even though it is usual that the investment and operating costs of, for example, an Nd:YAG laser, are higher than those of a CO₂ laser it is not self-evident that the total costs will summarize in this order too. A tight connection to production volume and to the specific requirements of the product exists.

A cost comparison within the field of microwave mechanics must take into account the requirements for handling systems. These depend on the working area but also and mostly on the accuracy of the positioning system. For example some laser subcontractors—who were consulted during the design of certain case examples that are shown in Sections 7.3, 7.5, 7.6, and 7.7.1—regarded an accuracy near 100 μm to be difficult when the workpiece dimensions reached 300 × 300 × 300 mm³.

The operating costs of CO₂ lasers consist of the consumption of gases or gas mixtures and electricity (standby, nominal, and chiller). The costs for the service or replacement of optical elements must also be taken into account. The operating cost of Nd:YAG lasers consists of electricity, excitation lamps, and maintenance. A comparison between different lasers should be related to the values of laser power and beam parameter product (BPP) found to be most appropriate for the product and manufacturing application. For example, according to Emmelmann (1998) the operating costs for lamp or diode pumped Nd:YAG lasers will be 2.8 to 3.6 times higher compared with diffusion cooled CO₂ lasers when cutting typical mild steels (thickness 1 mm) with feed rate 10 m/min. In welding, the difference is even more remarkable. For example, with a welding depth of 2 mm and a feed rate 9 m/min the Nd:YAG laser's operating costs are 4 to 5.8 times higher than those of a CO₂ Slab laser. In general, when the BPP or required laser power increases, for one specific laser type, the operating costs of the respective system will also increase.

In practical work, the machine-hour rate for laser processing is calculated as for most other manufacturing methods.

The efficiency of maintenance and associated services is important not only for continuous and cost-effective laser processing but also because the manufacturing steps involving laser are usually the most critical ones. An interruption of laser operation might therefore break the whole production line. It is obvious that this will cause higher costs than the simple servicing of the laser equipment would. Because of these reasons, preventive maintenance is needed and the costs for it are generally considered to be acceptable.

A commercial example by Messer Griesheim GmbH gives the following distribution of operating costs of a CO₂ laser (5 kW):

- Depreciation (62%);
- Maintenance (15.5%);
- Energy costs (10.7%);
- Working gas (9%);
- Laser gas (2.8%).

This kind of distribution is quite usual. It shows that, as the laser is a relatively cost-intensive tool, a high level of utilization should be guaranteed.

Programming costs and the costs of fixturing and workpiece manipulator systems depend mostly on the complexity of the geometry and the tolerance requirements. In the most difficult cases the preparations before actual laser processing can even be 95% of the total time. In sheet metal cutting, the programming time varies and can be up to 85% and the portion of workpiece and tooling set-up is only about 5 to 10%. These kinds of results are available from many commercial laser subcontractors. The possibility of transferring the cutting data from CAD software directly to the computer-based numerical control (CNC) laser will essentially shorten the programming time. In welding, the time used for fixing the workpieces can comprise up to 50% of total production time. This means that it is not enough to have a product designed for laser processing, but also the appropriate fixturing system must meet the respective requirements. Looking back to the example of different kinds of products, it is obvious that when the production volume is high, such as in the case of mobile phone components, the proportion of programming costs per unit will generally be insignificant. The costs for repeating the workpiece and tooling set-up, however, as well as the fixturing costs, are of key importance.

In some cases it is difficult to differentiate between the regular operating costs and some specific service costs. For example, the mirror and output

windows are typical wearing parts in CO₂ lasers and in a lamp pumped Nd:YAG laser the most important spare part is the excitation lamp. Both items can be calculated into the operating costs. The total cost for laser optics and components depends, to a high extent, on the desired properties of the laser system. Typical components, giving some choice for CO₂ lasers, are for example lenses, reflectors, output couplers, reflective phase retarders, polarizers, shift mirrors, parabolic mirrors, beam expanders, and beam delivery optics.

Unfortunately, laser subcontractors usually point out only the importance of investment and operating costs (different cost accumulation formulas are presented). Less attention is given to the cost factors due to design. The factors that the designer directly affects, however, are the design and redesign costs of the product, the design costs of fixturing arrangements, and the costs of CAD documents. Indirectly, these factors yield to CNC programming costs and to the costs of tooling and workpiece set-up. Designers' decisions have a high impact not only on the design costs but also on those of the production phase (see Figure 6.6).

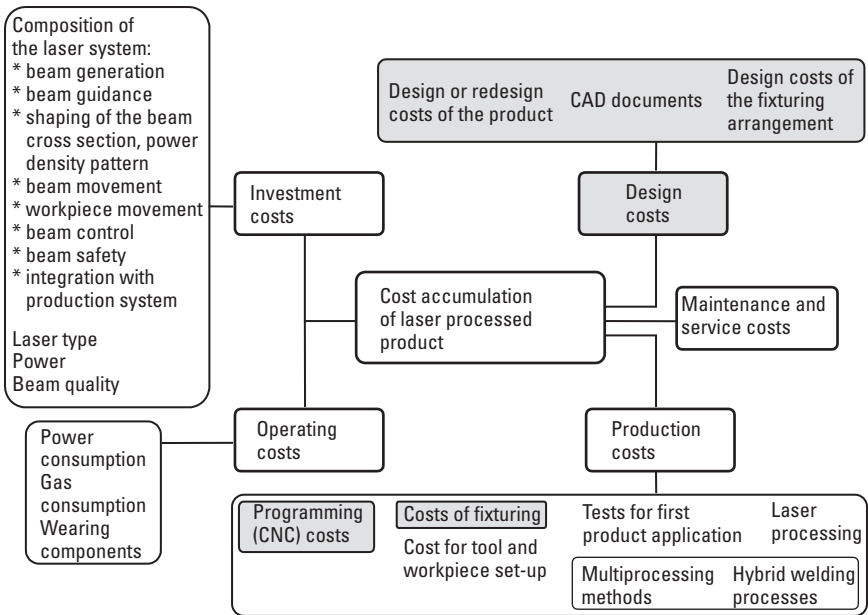

Figure 6.6 The cost factors of laser processing within the reach of the designer (high-lighted with a gray background) [1].

An early decision for laser processing can substantially increase the cost-effectiveness of the end result obtained through the design chain. It is also essential for the designer to be able to compare the total costs of the product between different laser types or laser systems, not just conventionally between different manufacturing methods. For welded constructions, for example, this implies a need to tune the traditional cost-estimating formulas accordingly.

6.11 Manufacturing Costs of Other Manufacturing Processes

Most of the modern manufacturing technologies and machine systems are developed for volume production. The limit for cost-effective manufacturing is usually at least 1,000 to 10,000 workpieces. The main reasons to encourage increasing production volume are as follows:

- Tooling costs are lower per workpiece.
- Model, die, and mold costs are lower per workpiece.
- Set-up times are shorter in machining.
- Nesting can be fully utilized in sheet metal work.
- Material costs are lower due to larger material sets.

Table 6.3 presents the most important cost factors for various groups of manufacturing technologies.

6.12 A Multilevel Optimizing Approach for Cost-Effective Production

The functional and performance levels of many microwave subassemblies are extremely high, so there are special requirements for manufacturing technologies as well. Let us continue by composing an illustrative example of an optimizing approach for laser processing, which has proved to be one promising manufacturing technology to meet the tight tolerances or other requirements. This approach can be presented in the form of an eight-level optimization model, which can easily be adapted to any of the most common manufacturing technologies. The schematic flowchart of this optimization model is presented in Figure 6.7.

Table 6.3
Cost Factors for Various Manufacturing Technologies

Manufacturing Technology	Most Important Cost Factors
Forging processes	Tool and die costs related mostly to complexity of the work-piece
Extrusion and drawing processes	Tool and die costs related mostly to the selected process (e.g., hydrostatic extrusion needs special equipment)
Sheet metal work	Tool costs related to the geometry of the work piece Costs will decrease if several manufacturing stages can be done with a multiprocessing machine Nesting makes it possible to use sheet metal material cost effectively
Powder metallurgy	Die and model costs Manufacturing processes of the powder itself are expensive Finishing processes Quality checking
Casting	Die and model costs Finishing processes Quality checking
Machining	Setup times Tooling and fixturing systems Programming (tool control)
Joining	Set-up times Pretreatment and posttreatment after joining

The First Optimization Level

The traditional systematic design approach has the manufacturability analysis placed near the end of the total design process, which easily leads to expensive and useless redesigns. On the other hand, CE design gathers together some reference groups less relevant in the early stages of the design process. To avoid these disadvantages and to recognize the most appropriate manufacturing method (in this case laser processing), the tuned design methodology for laser processing is used.

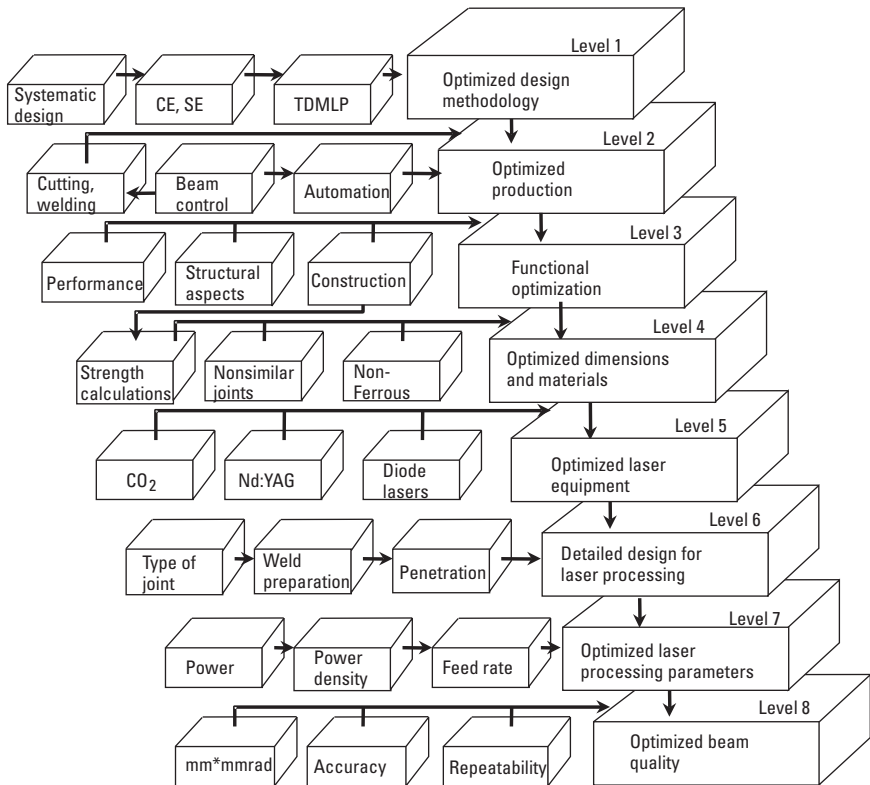

Figure 6.7 The schematic flowchart of the tuned optimizing algorithm for laser processing [11].

The Second Optimization Level

In this case, optimized production relies on two basic factors. First, there must be enough work for the laser beam (either different laser processing methods should be utilized or the production volume must be large enough) and solutions for automated production should be applied. In practice, this means that each laser processed geometry (for example either cut or welded) forms a module for the beam control and the more often these modules are used, the more effective the production that can be achieved. Secondly, it is obvious that the total time used for laser processing consists of the time when the beam is working and the time for presettings and preprocessing. It has been proven that the time typically used for these secondary operations forms at least 80% of the total time. Any operations to reduce the time used for presettings or preprocessing are therefore important for cost-effective

production. Also on this level, the advantages of the previously mentioned multiprocessing systems are clarified.

The Third Optimization Level

The most important view of optimization of subassemblies for microwave mechanics is probably the functional optimization. This level consists of two main stages: (1) performance-oriented optimization and (2) structural optimization. There are several examples of optimizing the properties of electronics housings against environmental changes and integrating the results of this optimizing process with the performance-oriented results (for example Jackson 1997). When dealing with microwave mechanics the requirements coming from the environment are very special.

For example, targets for corrosion resistance, bearing vibrations, and avoiding resonances, and properties to withstand hard impact forces and large changes of weather conditions (temperature changes, snow and ice loads, wind loads, humidity) are set for mechanical structures.

Even though these requirements seem to be mostly limits just for the structural optimization their influence on the final electrical performance is remarkable. For example, it is important to avoid corrosion in order to minimize contact resistance and reduce passive intermodulation. The resonances due to vibrations can also cause some malfunction (e.g., in YIG-based oscillators). This means that one special requirement, from the view of electronics, is to avoid microphonics (voltages or currents induced purely by mechanical vibration from contacting other similar parts). One functional requirement is, for example, the location of the radar antenna, which is a compromise of structural (airflow at a speeds of 3M) and performance-oriented (blind spots in the radar aperture) aspects.

The Fourth Optimization Level

The traditional optimization of dimensions and materials (usually it means the strength calculations) can be performed after the functional requirements are satisfied. It is obvious, however, that there must be an opportunity for feedback between the third and fourth level. An interesting addition for optimizing problems comes from the need to use nonferrous materials with non-similar joints, or the requirement of minimum weight, which might lead to the use of sandwich structures.

Various mechanical microwave subassemblies have components or elements that ought to be joined with the body of the construction by a special technology. This context of performance-oriented and structural optimization is further illustrated in Figure 6.8.

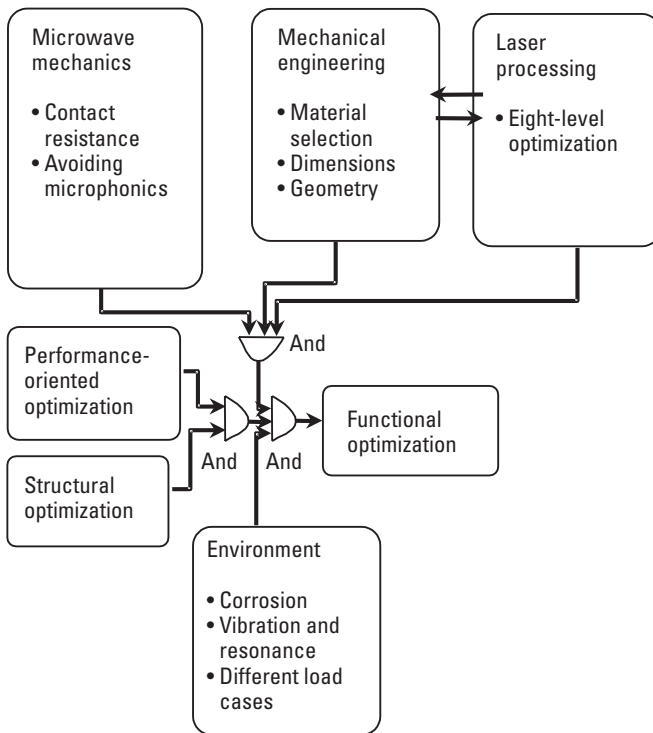

Figure 6.8 The context between performance-oriented and structural optimization in microwave mechanics [12].

The Fifth Optimization Level

In the literature, the advantages of laser processing are usually presented in general, and it is assumed that experts on laser processing will decide which laser equipment is the most appropriate for each workpiece. If the designer is able to write down the appropriate laser processing equipment on drawings or other documents, the time in production will be shorter. Unfortunately, there were no auxiliary numbers in Euronorms for, for example, different laser welding processes (CO₂ or Nd:YAG) before 2000. It has been proven that the heat input of CO₂ laser welding can be too high when joining narrow sheet metal components and that the Nd:YAG laser welding should be utilized instead. The common advantage of laser welding, however, is claimed to be “low heat input” during welding. Laser equipment has many details that affect the quality of the process. One of the recent topics is the role of optics in laser processing.

The Sixth Optimization Level

A detailed design for laser processing means that, for example, even though it is possible to guide the laser beam into difficult places with mirrors, there are some typical recommended joint geometries. There are several guidelines for designers to use to check whether the planned type of joints or joint preparation should be improved. If the designer has utilized the suggested tuned wizards and other computer-aided means, this level of the optimization chain should not cause any feedback to preceding levels. The highest total quality for laser processing is not always reached with a theoretically ideal mode pattern, but some optimizing procedure is needed.

The Seventh Optimization Level

Computer-aided tools for producing the documents of the design process should include feature-based properties so that the drawings or 3-D models could automatically include the suitable parameters (power, power density, and feed rate) for laser. At least the most typical material and thickness combinations should be found from the CAE library. It is well known, however, that the complexity of different geometries, new material combinations, and nonsimilar joints form such a large area of alternatives that some optimization might be needed.

The Eighth Optimization

The last level includes the optimization of beam quality. It partially depends on the type of laser equipment, so there is some connection with the fifth level and the seventh level (see Figure 6.9). Here we must extend the service and maintenance operations to robotics and automation used in the manufacturing process. Some statistical methods for process control are also needed to ensure that errors can be found and their reasons clarified.

The problems with these kinds of multilevel optimization procedures are widely discussed in the literature. The Taguchi method, factor analysis, or fuzzy approach, for example, can be applied to solve the task. First, however, an overall model, like the one presented here for laser processing, is needed. It prevents a contradiction between different locally found optimum solutions and helps to choose the appropriate tools for solving the problem. The eight level model guides the whole optimizing task and connections between different levels can be taken into account.

During the development of laser processing as an industrial manufacturing technology the question of equipment costs has been an important factor. In the early stages and years of development, the use of laser was

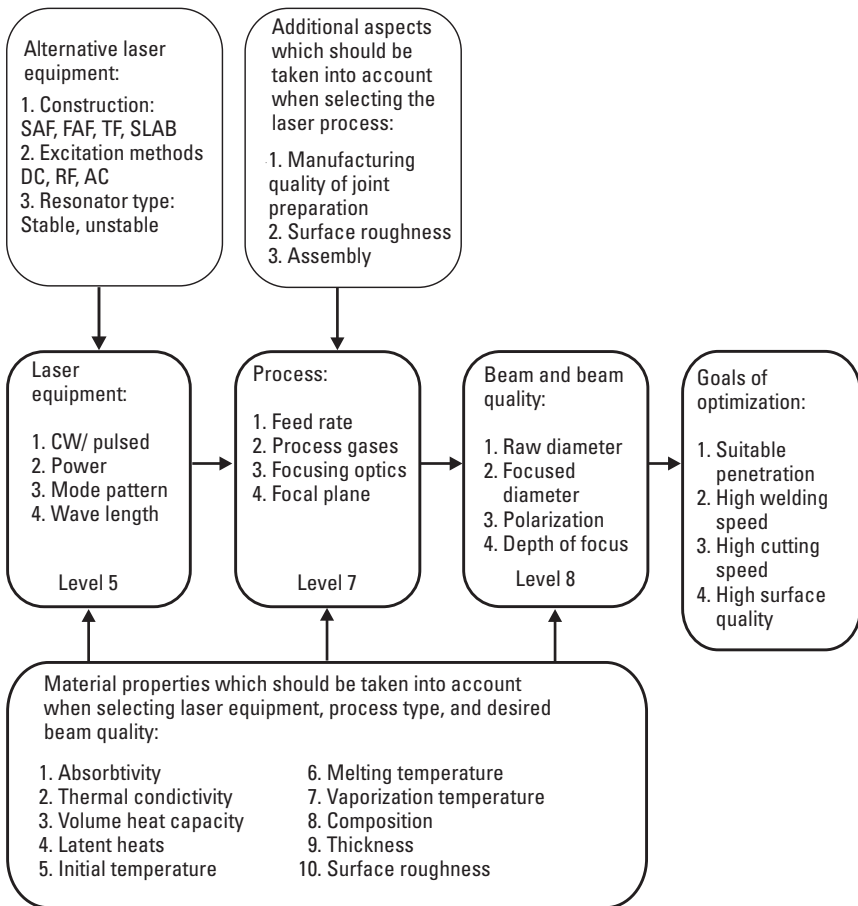

Figure 6.9 The connections between the fifth, seventh, and eighth optimization levels. The optimal laser parameters depend partly on equipment, process used, and materials. The applied equipment, however, fills specific quality requirements [1].

justified in the cases where no other manufacturing method would have been possible. Nowadays, cost-effective mechanical engineering also requires benefits in volume production. The more laser processed, series-produced parts the construction has, the easier it is to achieve benefits with laser. If it is possible to use different laser processing methods or multiprocessing equipment, savings in fixturing costs are remarkable.

Laser processing can also be used in cases where it is possible to improve the product's lifetime or performance. For example, the following

ratios have been derived for microwave mechanics in order to estimate the results of the optimizing procedure [12]:

- Costs [€] [↓] / attenuation [dB] [↓];
- Costs [€] [↓] / gain [dB] [↑];
- Costs [€] [↓] / noise figure [dB] [usually ↓];
- Costs [€] [↓] / phase error [rad] [↓];
- Costs [€] [↓] / lifetime [h] [↑];
- Accuracy [IT-grade] [↓] / attenuation [↓], gain [↑], or noise figure [↓] [dB];
- Distance between electric components [m] [usually ↓];
- Weight [kg] and dimensions [m³] of the product [usually ↓].

These ratios include the total cost of the product, which means that the common characteristics describing the effectiveness of production and the investment costs are taken into account. Using these ratios, the designer calculates, for example, the costs due to changes that should be made to the product to improve the maximum gain with one single dB-unit. After that, the design procedure continues by calculating the cost ratios (i.e., for attenuation, noise, and phase error). The arrows [or] after each unit describe whether the aim is to maximize or minimize the corresponding property. For example, the designer is searching the minimum manufacturing accuracy (IT-grade), which still satisfies the performance requirements of allowed attenuation and noise, yet gives the desired gain level. After having gathered all the ratios listed above, the designer is able to make a numeric and objective comparison between various product alternatives.

The same kind of cost accumulation analysis, before any practical design work of the product itself, is highly recommended for any manufacturing technology.

References

- [1] Eskelinen, H., *Tuning the Design Procedures for Laser Processed Microwave Mechanics*, LUT: Acta Universitatis Lappeenrantaensis 87, 1999.
- [2] VDI 2221, VDI Guidelines, *Systematic Approach to the Design of Technical Systems and Products*, Verein Deutscher Ingenieure, Aug. 1987.

- [3] Eskelinen, H., "Application of Concurrent Engineering in Innovative Manufacturing and Design of a Milled Microwave Filter Construction," *Proc. of the Managing Innovative Manufacturing MIM2000-Conference*, Birmingham, UK, Jul. 17–19, 2000, pp. 230–236.
- [4] Miller, L. C. G., *Concurrent Engineering Design, Integrating the Best Practices for Process Improvement*, Michigan: Society of Manufacturing Engineers, 1993.
- [5] Portioli, A., and N. Singh, "Framework for Integration of Production Management Issues and Concurrent Engineering," *International Journal of Systems Science*, Vol. 28, No. 9, 1997, pp. 877–881.
- [6] Asiedu, Y., and P. Gu, "Product Life Cycle Cost Analysis: State of the Art Review," *International Journal of Production Research*, Vol. 36, No. 4, 1988, pp. 888–908.
- [7] Hoffman, D. R., "Overview of Concurrent Engineering," *Proc. of the Annual Reliability and Maintainability Symposium*, IEEE, Piscataway, NJ, Jan. 19–22, 1998, pp.1–7.
- [8] Stahl, J., et al., "Concurrent Engineering of Work and Production Systems," *European Journal of Operational Research*, Vol. 100, No. 2, 1997, pp. 375–398.
- [9] Brookes, N., and C. J. Backhouse, "Variety and Concurrent Engineering," *Manufacturing Engineer*, Vol. 76, No. 2, 1997, pp. 72–75.
- [10] Duffy, V. G., and G. Salvendy, "Prediction of Effectiveness of Concurrent Engineering in Electronics Manufacturing," *Human Factors and Ergonomics In Manufacturing*, Vol. 7, No. 4, 1997, pp. 351–373.
- [11] Eskelinen, H., "A Mathematical Tool for Optimising Limited Volume Laser Production of Passive Microwave Components," *Proc. of the Stimulating Manufacturing Excellence in Small and Medium Enterprises SMSSME-2000-Conference*, Coventry, UK, Apr. 16–20, 2000, pp. 457–465.
- [12] Eskelinen, H., "A Look at Optimised Laser Processing for the Manufacturing of Passive Microwave Modules," *Proc. of the 29th European Microwave Conference*, München, Germany, Oct. 4–8, 1999, pp. 365–368.

Part 2

Manufacturing Technologies for Some Passive Microwave Components

7

Welded Components

7.1 Welding Processes for the Topic Area

To be able to fully utilize the specialized joining instructions for welded microwave components and constructions, one must understand some basic rules of microwave technology—especially the theory of microwave propagation. In practice, we can divide the research area into four different sections:

1. Weldability aspects for cavities, which, in principle, consist only of either perpendicular or parallel conducting walls;
2. Weldability aspects for nonsimilar joints (several material pairs or different cross-section geometries are typical for microwave modules);
3. Instructions for manufacturing hermetic enclosures (or in some cases, enclosures just to minimize the coupling of electromagnetic noise);
4. Instructions for joining or encapsulating electronics (most of the components do not withstand heavy physical loads, large changes of temperature, or high levels of external magnetic fields).

Typically, the initial material selection is made according to the performance requirements of the designed radio frequency construction. The most important criteria are the three constants: permittivity ϵ [F/m], permeability μ [Vs/Am], and conductivity σ [S/m]. This means that, to ensure the

weldability aspects, the appropriate welding process must be chosen and that the exact joining instructions related to the joint geometry are also necessary.

To be able to make extensive use of microwave theory, we can illustrate the physical rules by looking at a simple cavity resonator. If we remove one of the end walls we can theoretically get a simple radio frequency transducer. Imperfections in the cross-sectional structure of the cavity, misalignments, material dents, severe oxidation, and imperfect joints between the walls will all add attenuation, generate unwanted higher propagation modes due to strange boundary conditions, distort the polarization pattern, and lower the electrical efficiency.

If further extended to a rectangular horn antenna, the shape and deformations of the horn section have a great impact on the radiation pattern and the net gain of the transducer. Basically, the transducer opening should be considered as a constant phase surface from which a plane wave is radiated towards a test sample, but all misalignments of the walls will impair this performance. These aspects are of highest interest in welded constructions due to the possible deformations caused by the heat input.

If we perform a rough comparison of the possibilities of different welding processes we can make the following list to help with choosing the most appropriate technology:

- Arc welding processes can generally not be used near semiconductor components that cannot stand high temperature changes or rapid changes of the strength of electromagnetic fields.
- Many individual components or insulating materials often cannot stand high temperatures and, depending on the mechanical construction, the heat input of most common welding processes can be too high.
- Beam welding processes are promising in many cases due to their relatively small heat input and narrow weld penetration but they suffer from problems when trying to weld highly reflective materials.
- Ultrasonic welding is a good choice not only for plastics, but also for different metallic material pairs, although the geometry of the tooling system complicates the application.

7.2 Laser Welding in General

During the past 10 years, laser welding (with its applications) has been regarded as one of the most promising solutions for manufacturing mechanical

joints in microwave modules. A laser process is generally suitable for both seam and spot welding. In principle, laser beam welding is divided into thermal conduction welding and keyhole welding. Thermal conduction welding means that material melts because of absorption and following thermal conduction of the laser radiation energy. In keyhole welding, the material reaches the evaporation temperature locally as a consequence of focused radiation. Because of the evaporation, a capillary is created. Laser-induced plasma is created in the metal vapor streaming away above the workpiece and in the capillary. From the walls of the capillary, the input energy will transfer into the melt and solid material. The capillary increases heat absorption. This means that the laser beam can penetrate into the material. Nowadays it is possible to achieve a 25-mm penetration in steel. In laser welding, if it is necessary, the cooling melt can be protected from oxidation by an inert gas. If welding causes metal spatter, this can be deflected by compressed air or other means.

To increase the efficiency of laser welding, it is possible to use a combination of laser and other welding processes, called laser hybrid welding, such as tungsten inert gas (TIG) welding or plasma arc welding with laser. In TIG welding, the filler metal is supplied from a filler wire. Because the tungsten electrode is not consumed in this welding process, a constant and stable arc gap is maintained at a constant current level. The filler metals are similar to the metals to be welded and flux is not used [1, 2]. By using a plasma-augmented laser, for instance, the welding speed for steel alloys is 30% greater and the speed for aluminum is 50% greater than with pulsed laser alone. Hybrid processes can be used to reduce difficulties if the carbon content of the material is higher than 0.2%. One of these processes is the inductively supported laser welding, which makes it possible to weld steels with carbon content up to 0.3%. It is also possible to use twin beam laser welding where two laser beams are used simultaneously. With this method, it is possible, for example, to improve the welded joints of highly reflective materials. Laser spot welding is generated by a single laser pulse or by series laser pulses. For small structures, a pulsed Nd:YAG laser is considered cost effective.

To improve the corrosion resistance, strength, and metallurgical structure of joints, a combination of CO₂ laser and metal inert gas (MIG) welding can be successfully utilized. In MIG welding, the weld area is shielded by an effectively inert atmosphere of argon, helium, carbon oxide, or other gas mixtures. The consumable bare wire is fed automatically through a nozzle into the weld arc [1, 2]. For repair welding of nuclear power plant steam generator heat exchanger tubes it is reasonable to utilize TIG-Nd:YAG hybrid process.

In addition to hybrid processes, practical industrial applications of laser beam microwelding are utilized to enlarge the application area of beam processes. Difficult boundaries for the heat conduction in joining processes, for example, can be fulfilled with laser beam microwelding in the field of electronic production.

The most important advantages of laser welding are: (1) the possibility of joining dissimilar metals, (2) the possibility of joining difficult-to-reach targets, (3) reduced heat affected zone (HAZ), (4) suitability for automation, (5) good repeatability, and (6) reduced need for postprocessing. The maximum welding speed, maximum penetration, and the most suitable type of the laser, however, are tightly combined. Compared for example with TIG welding, the welding speed with laser is generally three times higher. In laser welding, the longitudinal and transverse shrinkages of a butt-welded workpiece are, typically, only a tenth of the respective figures of TIG welding.

During laser soldering the solder material can be added in the form of wire or paste. When a focused laser beam is used to solder the target (for example an electronic component) only the parts to be connected are heated (not the whole component). With conventional soldering processes this is difficult. One promising application is the automated soldering of radio frequency screens to circuit boards in mobile telecommunication devices. Joining by soldering is possible for different kinds of material pairs if chemical reactions in the application environment do not prevent it.

To reach the best welding productivity a careful comparison between various laser equipment types is recommended: Fast axial flow (FAF) CO₂ lasers with a DC-excitation and a stable resonator are suitable for fine welding. If RF-excitation (not to be confused with a radio frequency application!) is used, then the best application area is macro welding. Cross-flow CO₂ lasers are good for fine and macro welding. Even though Slab lasers are very good for all cutting processes they can be used for welding as well. High-power Nd:YAG lasers are suitable for welding. The major advantage of Nd:YAG lasers over CO₂ laser is that their beam can be transmitted to the workpiece along optical fibers and applied on highly reflective materials. Low power diode lasers are suitable in the area of welding of plastics. High power diode lasers can be used for heat conduction welding.

7.2.1 Parameters of Laser Welding

To reach the best welding quality an optimized selection of the laser parameters is in key role. The parameters of laser processing can be dealt in three principal groups: beam parameters (which depend mostly on system

properties and are not changed during the process), actual process parameters, and parameters depending on the raw material. The most important beam parameters are polarization, wavelength, beam diameter, mode, and divergence. The most important process parameters are laser power (or power density), operating speed (or beam interaction time), focal length, diameter and distance of the focus, and the distance between laser head and the workpiece. During the process it is also possible to use shielding gases, pulsed applications or spinning trajectory of the beam. There are several parameters that depend on the raw material itself such as absorptivity, thermal conductivity, volume heat capacity, latent heats, melting and vaporization temperatures, composition, thickness and surface roughness. In practice beam propagation factor, times diffraction limited factor, the beam parameter product and the so-called F-number are used for the definition of beam quality. This F-number is quite commonly used to describe the properties of focusing. It is simply the relationship between the focal length and raw (initial) beam diameter. On the other hand the beam mode patterns are used to classify the different lasers for specific process areas. The higher the order of the mode is, the more difficult it is to focus the beam to a fine spot, since the beam is no longer coming from a virtual point. For practical industrial applications the laser parameters presented above and the recommended laser processing methods are usually combined by creating diagrams that either present the power density related to beam interaction time or the beam parameter product.

7.3 Laser-Welded Stripline Filter

In practice, the performance of radio frequency components depends to a great extent on their mechanical construction, dimensions and materials. Common features of a microwave design include a well-defined impedance, a controlled attenuation and the desire to select particular wave modes or other propagation characteristics. The electrical behavior very often relies on special boundary conditions defined by the mechanical structure surrounding the actual wave. Imperfections in the material or the shape will thus immediately alter the field direction or pattern or give a possibility for such a change if induced by other external phenomena.

The basic mechanical cross section of the laser-welded third-order Butterworth filter is demonstrated schematically in Figure 7.1 and a photo is shown in Figure 7.2. The filter construction (see the drawings and CAD models on the attached CD-ROM) consists of two cover plates, four border

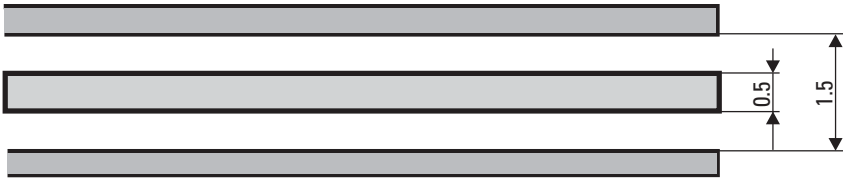

Figure 7.1 The stripline cross section. The center conductor is a 0.5-mm metal sheet of variable width and the air gap above and below it is 0.5 mm as well [3].

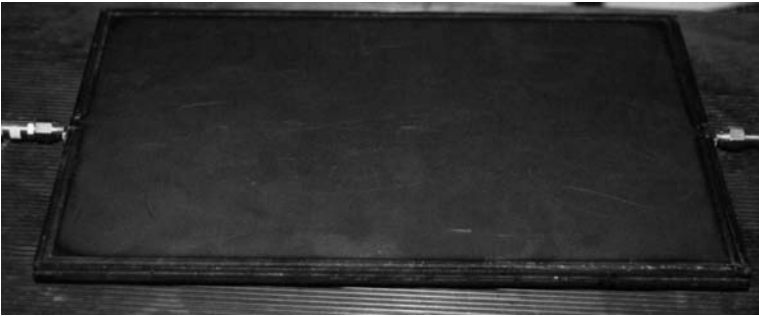

Figure 7.2 A photo of the laser-welded filter. The main dimensions are (L×W×T) 254 mm × 185.2 mm × 4.5 mm.

plates, a middle plate, and two SMA connectors. The performance requirements of the filter are minimal attenuation in the filter passband, steep slopes between 3 dB and stopband, and the reduction of unwanted propagation modes inside the filter geometry. A key requirement is the ability to maintain the calculated insulation depth between the two parallel conducting layers and the center strip all over the planar construction. Also, a well-defined and straight-edged strip cross section as well as a continuous galvanic contact along the inner line seams is required. The manufacturability analysis for laser cut sheet metal parts is discussed later in Chapter 10 and detailed CAD documents are presented on the attached CD-ROM.

All the plates are cut with laser and all the joints are laser welded in order to ensure that the required tolerances are achieved. In almost every case CO₂ laser could be used both for cutting and welding. However, the Nd:YAG laser was needed to join the pin of the connector with the narrow strip of the middle plane. The reason for this is the material of the pin, which is gold plated beryllium-copper, having a thermal conductivity about 14

times higher than steels. It is also necessary to avoid too high heat input because the PTFE-insulator between the pin and additionally, the middle and border plates should not melt. According to practical tests, soldering does not ensure reliable joints in this case. This detail is presented in the drawings on the attached CD-ROM.

Even though the CO₂ laser has been used to join the narrow border plates with the middle plates, it might have been better to use the Nd:YAG laser also in this case to avoid deformations due to heat input. Laser welded joints between the border plates and the middle plate can be manufactured in two ways: either “fillet” or seam welds can be used. To produce a better performance of the filter the “fillet” welds from both sides of the middle plate are recommended. If there are possibilities to relax the performance requirements, seam welds are optimal for manufacturing—all the three sheet metal parts can be welded at the same time (see the CAD-documents on the attached CD-ROM). The SMA connectors can be laser welded either on the assembly plates or the construction can be changed so that the connectors are welded directly to the combined cross section of the five plates. In this case the thickness of the covering plates must be increased. However, when the walls are used to mount the filter, the later alternative cannot be used.

A tiny pocket for the SMA connectors’ PTFE-insulator must be manufactured into the both covering plates [4]. Even though these pockets are usually machined and they therefore need a new manufacturing phase, the other possibility to form the insulator might disturb the filter’s function.

To avoid harm due to moisture, the construction must be hermetic, which can be ensured with a laser-welded covering. Corrosion can be avoided by using stainless steel instead of traditional copper or aluminum. If needed, however, it is not a problem to manufacture the three inner plates of different material than the covering ones.

The performance tests proved that the filter input impedance shows a nearly perfect match over the specified frequency range (see Figure 7.3). However the unit is still nonreciprocal which clearly suggests some problems in maintaining a stable airgap (0.5 mm) when utilizing CO₂-laser in welding.

A real-time interaction of mechanical and microwave designers, assisted by manufacturability analysis and computer-aided means, can lead to innovative filter solutions. A thorough understanding of manufacturability judgment and knowledge about modern laser processing is vital for a success in high volume production. In this case it is most essential to notice the differences between the application areas of CO₂ and Nd:YAG-lasers. The comparison between different welding technologies is presented in Table 7.1.

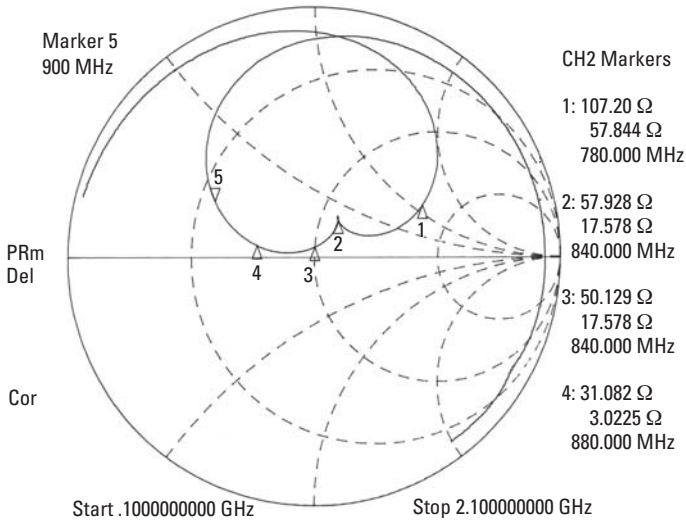

Figure 7.3 The filter input impedance is nearly perfect over the specified frequency range. However the unit is still nonreciprocal. This indicates problems in maintaining a stable airgap. The passband should be from 780 MHz to 880 MHz.

Table 7.1

Comparison of Different Sheet Metal Joining Technologies Suitable for Microwave Components

Joining Technology	Manufacturability	Performance
	- Extra preassembly or assembly work is needed	+ Hardly acceptable performance due to poor EM or hermetic shielding properties
	+ Normal degree of difficulty	++ Hermetically good products
	++ Structural weldability is easy	+++ Both hermetically and geometrically good properties of the joint
		++++ Hermetically, geometrically, and also functionally excellent joints
CO ₂ laser, fillet welds	-	++++
CO ₂ laser seam welds	++	++
CO ₂ laser spot welds	++	+
Nd:YAG laser, fillet welds	-	++++
Nd:YAG laser, seam welds	++	+++
Glued joints	+	+++

Unfortunately, scientific research and industrial development work of different welding processes is too often focused only on the improvement of the process itself. Though the original reasons to enhance manufacturing basically come from the functional requirements of innovative products, there is seldom a connection to product development. Painful enough, after several iteration stages between manufacturing and design we usually are ready to start thinking the problems of volume production! Many new products are more or less cross-technological and a deep knowledge of both mechanical and electronic engineering is needed to ensure cost-effective design and manufacturing. Especially in microwave mechanics, it seems to be a “rule” that several compromises should be made to find the most cost-effective way to manufacture welded cavities for resonators or waveguides, hermetic enclosures or reliable joints for standardized connector pins. If for example the possibilities of laser beam welding and ultrasonic welding are utilized when trying to find these compromises at least some cost-effective solutions can be found for industrial purposes.

The previous sample and the test results show clearly that the design process of the filter itself consists obviously of three main areas, which are performance oriented design, manufacturability oriented design, and material selection oriented design.

Because these areas are at least partially overlapping, a specific optimizing algorithm, which was presented in Chapter 6, is needed to find the final solution of the design task.

Even though it is a well-known fact that, due to laser processing, the heat input during welding is “low.” In this context, however, it proved to be difficult to handle welding deformations when either CO₂- or Nd:YAG-laser seam welds were used. The wider strips of the middle plate tend to twist which caused a short circuit inside the filter (see Figure 7.4 in which this result is observed from measurements). To avoid this disadvantage two alternative changes in the manufacturing process are possible: (1) a new jig construction can be developed to enable tension stress during welding and cooling process or (2) laser spot welding can be utilized when the covering plates are welded with middle and border plates. On the other hand, due to the environmental requirements of the application, stainless steel was used which actually made it a bit easier to utilize laser because the carbon content was low. All sheet metal parts were laser cut and no further preparations for welding were needed.

Another difficult detail was the joint between the middle plate and the connector. It is hard enough to find suitable laser parameters for this kind of a material pair. Additionally, the heat input must be limited to avoid

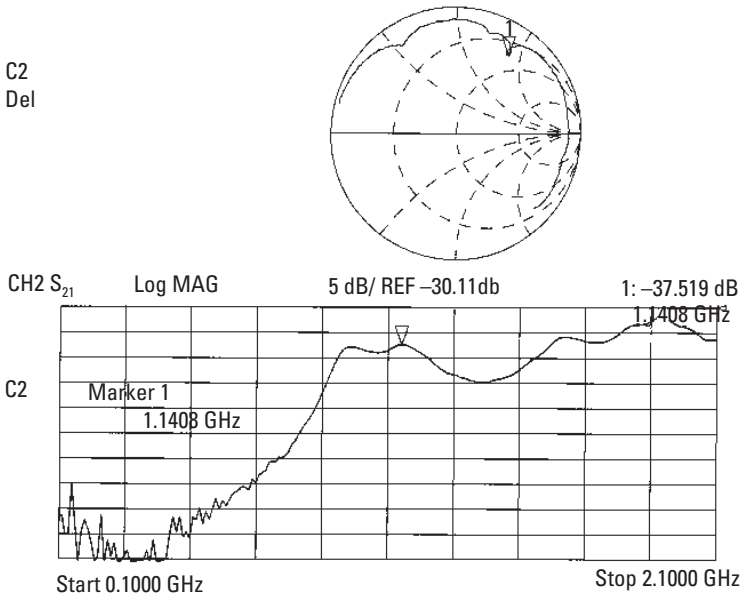

Figure 7.4 The wider strips of the middle plate tend to twist despite of the use of a laser, which caused a short circuit that forces the impedance plot on the outer skirt of the Smith diagram. Also, there is considerable attenuation all through the frequency range in the lower recording. To avoid this, two alternative changes in the manufacturing process are possible: (1) a new jig construction to enable tension stress during welding and cooling or (2) laser spot welding [5].

damaging the PTFE insulation around the rod. In this case, the rod end was to be grinded to form a symmetrical cross section with the middle plate and the Nd:YAG-laser was used (see the detailed 3-D models and drawings on the attached CD-ROM).

The possible deformations of the middle plate are caused by several reasons. There is always some initial contortion in the raw material due to the forming (rolling) process of the plate. Also cutting processes, which are based on melting, cause remarkable deformations to the plate. These unwanted distortions and deformations should be added to those made by the actual welding process.

Some of our most important experiences of using a laser for filter manufacturing are summarized in Table 7.2. Selected practical solutions for utilizing laser welding in this kind of products are collected in Table 7.3. According to our results, so-called “well-known facts” or advantages should

Table 7.2

Some Experiences of Using Laser Processing for Sheet Filter Manufacturing

A Well-Known Fact About Lasers	Challenges During This Filter Project
Heat input during laser cutting and welding is "low."	Distortions and deformations due to laser cutting and welding especially if CO ₂ was used.
No finishing is needed after laser welding.	Grinding of the seam welds needed (excess weld metal) before assembly.
Laser cut edge is of high quality and no finishing is needed.	Sharp stripline edges required a very exact optimizing of the pulsed Nd:YAG laser.
Dissimilar joints with different material pairs are easily welded.	A reliable joint between the SMA center pin and the strip of the middle plate questionable.
Heat input is low and accuracy of beam control is high, which enable work near easily melting materials.	Special arrangements necessary to protect the PTFE insulator (due to the requirement of hermetic construction).

Table 7.3

Some Solutions to the Problems of Using Laser Processing for Sheet Components

The Problem of Laser Processing	Solution During This Project
Distortions and deformations due to the heat input of cutting or welding	-Cutting and welding from opposite sides to minimize residual stresses -Jig ensures stable plate tension during welding -Optimal equipment (Nd:YAG) and parameters
Finishing of the seam welds before assembly	-All five layers welded simultaneously with one seam (positioning by guide holes, thickness reduced to 3.5 mm, beam aligned to the inner border of the middle plate)
Problems with different materials or material pairs	-Pulsed Nd:YAG for the Cu/Be- pin -Stainless steel easier than conventional ones
Problems with different geometries in welding and cutting:	-Pulsed Nd:YAG for the required quality and sharpness of the cut edge in striplines -Nd:YAG enables to join wire-like geometries

be reconsidered at least when trying to manufacture similar sheet assemblies. The instructions for quality improvements in laser processing

given in recent literature, seem to work quite satisfactorily. However, our results give a reason to ask for a more objective analysis of certain manufacturing technologies and equipment—to reveal and present the disadvantages of commercially available technology.

7.4 Utilizing Ultrasonic Welding in Filter Constructions

In ultrasonic welding (USW), two surfaces to be joined with each other are subjected to a static normal force and oscillating shearing stresses. These shearing stresses are applied by the tip of the transducer. The frequency of oscillation is typically between 10 and 75 kHz. Proper coupling between the sonotrode and the transducer is important for efficient operation. The shearing stresses cause plastic deformation at the interface of the two components to be joined. Possible oxide films or other contaminants will be broken through during the process, which ensures reliable joint. The temperature generated in the weld zone is usually in the range of one-third of the melting point of the metals to be joined. This means that neither melting nor fusion takes place. The mechanism to join thermoplastics with USW differs from that of metals and melting does take place at the interface. USW process can be used with both metallic and nonmetallic materials also including bimetallic strips. The welding tip can be replaced with a rotating disk, which enables a USW seam-welding process.

To enable the use of other standardized components and cables in microwave applications, designers typically select commercial coaxial connectors, (e.g., of the SMA type). From the weldability point of view, these connectors are difficult. First, the center pin is made of copper-beryllium-alloy which has proven to be complicated both for CO₂- and Nd:YAG lasers (reflecting copper makes it necessary to use Nd:YAG but beryllium seems to evaporate easily, which causes pores into the weld). Secondly, the center pin is surrounded by a PTFE-insulator cylinder, which melts easily. Difficult enough, the center pin is in most of case plated with gold, which causes a good thermal conductivity directly to the melting insulator and gold is even more reflecting than copper. We have studied if it were cost effective enough to utilize ultrasonic welding for joining, for example, the center conductor of a microwave filter with an SMA connector's center pin as illustrated in Figure 7.5 and Figure 7.6. Similar research seems to be going on in the aerospace industry, where several welding processes are compared for electro-tab connections. It is possible to vary the parameters and vibration systems of ultrasonic welding to make it suitable for, for example, continuous welding of aluminum plates of different thicknesses. In our case the problems stay on

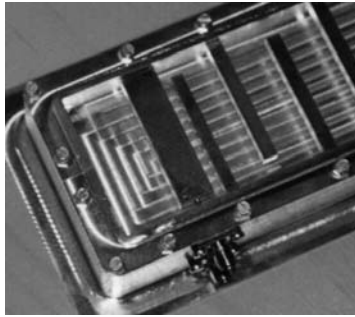

Figure 7.5 An enlarged photo of a milled construction where the SMA center pin was joined only by the appropriate fitting $\text{Ø}1.28 \text{ H7/js6}$ according to standard ISO 286-2 (allowed diameter is 1.2770...1.28930 mm) between it and the hole in the resonator.

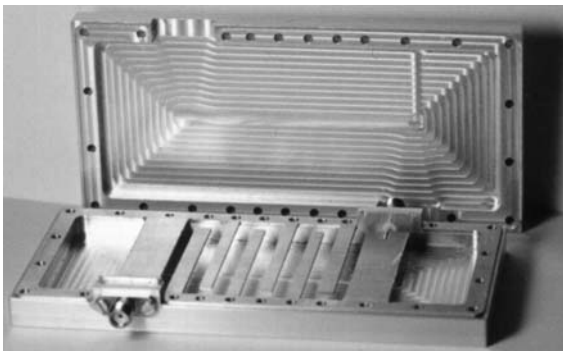

Figure 7.6 In the second variation the milled resonator is replaced with a metal sheet. In this case the fitting joint can be replaced with USW.

the differences between the materials to be joined. Even though aluminum or copper are not problems, in some cases the beryllium alloying of the center pin is difficult to handle. In specified cases it has proved to be useful to add a medium into the joint (like titanium). Here, however, gold plating is done for improving the electrical performance of the connector—not for weldability aspects.

To convince ourselves of the advantages of USW application, we have compared fittings, soldered, glued, and welded joints (Nd:YAG-laser welding and USW) between the center pin and the hole made into the end of the resonator.

In the first prototype we used an ISO-standardized fitting $\text{Ø } 1.28 \text{ H7/js6}$ (identification according to standard ISO 286-2), which allows a tolerance range of -3 to $+13 \mu\text{m}$ (allowed diameter is 1.2770 to 1.28930 mm). Laboratory tests were very promising, but there were four main reasons why this solution was rejected in mass production:

1. The diameter of the SMA center pin is not constant, which hampers the reliability of the fitting (and there is no use to machine the pin).
2. Temperature variations and different coefficients of heat expansion of the pin (CuBe2) and the resonator (ALUMEC) change the properties of the fitting.
3. The manufacturing of the precise hole needs special manufacturing stages.
4. The thickness of the center conductor of the filter should be relatively large to make it possible to drill a hole into its end, which increases weight.

We managed to find a suitable material for the filter body (ALUMEC) to withstand the milling forces. Appropriate milling tools were also developed to ensure the sharpness of each resonator root. It was thus reasonable to start searching for other ways to make a more reliable joint and minimize the weight of the construction.

The most conventional way is to make a soldered joint between the center pin and the respective resonator. This is not possible, however, if we are using the previously mentioned fitting approach. On the other hand, because we have had some promising results about laser processing in general we started to study if it were possible to use pulsed Nd:YAG. If we change the resonator shape from a milled part into a sheet metal design, we might be able to (1) cut the geometry, (2) mill a slot for the center pin, and (3) weld the pin together with the conductor sheet with LB welding. The principal solution is presented with a 3-D CAD model on the attached CD-ROM. The third possibility could be the use of some conductive epoxy adhesives (e.g., silver based ELECOLIT 325).

We have tested several soldered joints. Their use is difficult and even questionable for this particular purpose because:

- We can't guarantee the long-time properties of the soldered joint.
- Heat input might be too high and can lead to unwanted transformations or even melting of the insulating elements of the connector.

- The quality and dimensions of the joint can vary a lot and are difficult to verify.

Laser processing seems to solve the problems of soldering and it even offers possibilities to carry out several manufacturing stages with the same equipment. However, it turned to be difficult to handle the material pair CuBe₂ versus ALUMEC due to the beryllium alloying. The gold plated SMA center pin makes handling even more difficult. According to our results, the use of glued joints is a risk because the absorption of humidity (up to 0.3%) might decrease the joint's properties and, further on, the filter's performance.

Like previous results clearly show either laser welding, soldering or use of adhesives cannot produce acceptable solutions for our purposes and there is a need to try to find more advanced technologies. Ultrasonic welding has been widely used for joining plastics in all kinds of industrial applications. Much work has been done to reach an acceptable production level for industrial applications also when welding metallic joints. For the application itself it would have been most suitable just to make an overlapping joint where the circular pin is welded directly to the planar sheet. Theoretically the needed pressing force would produce the necessary area between the work pieces (in principal the connecting area would otherwise be a pure line). In our application, however, we can't change the size of the air gap inside the filter if we still want to maintain the performance. If we still want to use the sheet metal construction we can (1) change the commercial SMA-connector type from 23-SMA-50-0-13 (Huber+Suhner catalogue) into, for example, 23-SMA-50-0-12 (strip-like center pin) or else (2) we must mill and grind the rounded center pin so that the cross section is a half-circle.

For practical work, it is hard to find the suitable welding parameters for the first case. We need the appropriate values for the compressing force amplitude, frequency, and time.

The tooling and fixturing systems are for both cases relatively simple. For USW approach and further on regarding microwave performance it is important that we achieve acceptable surface roughness. It is regrettable that the compressing tools partially damage the surface (even 0.3-mm errors can be caused; see Figure 7.7). It is even more painful that the grinding procedure for CuBe alloys seems to need single-point diamond grinding instead of a diamond wheel.

In our welding tests [6] we have used USW-equipment, which was operating with the vibration frequency of 20 kHz and which had an adjustable welding pressure or clamping force from 45 to 320N and an ultrasonic

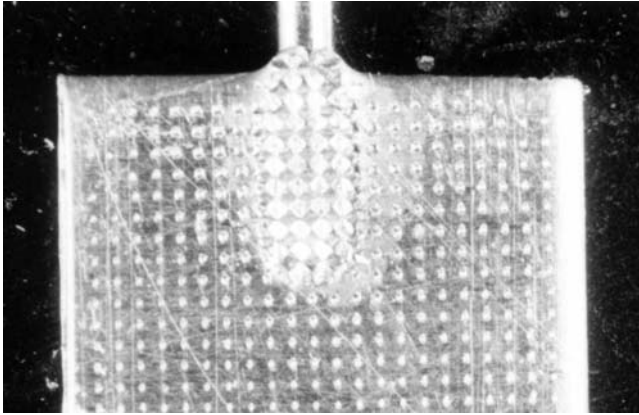

Figure 7.7 The compressing tools used in USW processes partially damage the surface up to a roughness of 0.3 mm. This must be taken into account when optimizing the performance of the filter.

converter of 3 kW. The sonotrode that was used in our tests, had a pressing area of 4.5 by 4.5 mm with a surface roughness of 0.3 mm. During the welding process, the aluminum feeding strip was placed at the lower position and the center pin on the strip against the sonotrode.

During our tests we have varied the welding parameters as follows:

- Pressing force from 217 to 234N;
- Amplitude of the sonotrode vibration 24.5 μm ;
- Welding time from 0.3 to 0.5 sec;
- Welding energy from 253 to 149J.

As the photo in Figure 7.8 shows, we managed to find the optimum values for welding parameters to manufacture an appropriate joint between the strip and the pin. Quite large test sets are necessary to find the optimum parameters for specified materials and joint geometries. An understanding of the guidelines of USW-weld analysis is needed. Aluminum alloys can either corrode during the etching process when manufacturing the test piece for the microstructure photographs or some oxide layers can destroy the surface to be photographed when cutting the test samples (this phenomenon is illustrated in Figure 7.9.). Because the USW process is not based on melting it might be easy to forget to compose the hardness profile of the joint.

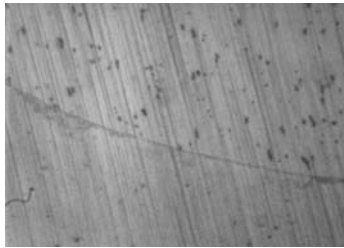
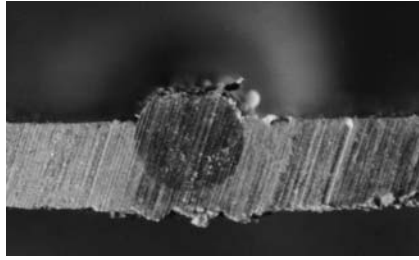

Figure 7.8 A USW-joint cross section between the strip and the pin (top). The welding parameters were $F = 217$ N, $A = 24.5 \mu\text{m}$, $T = 0.38$ sec, $E = 190$ J. The microstructure analysis looks almost perfect and the contour line of the pin can hardly be seen (enlarged 340 x, at bottom).

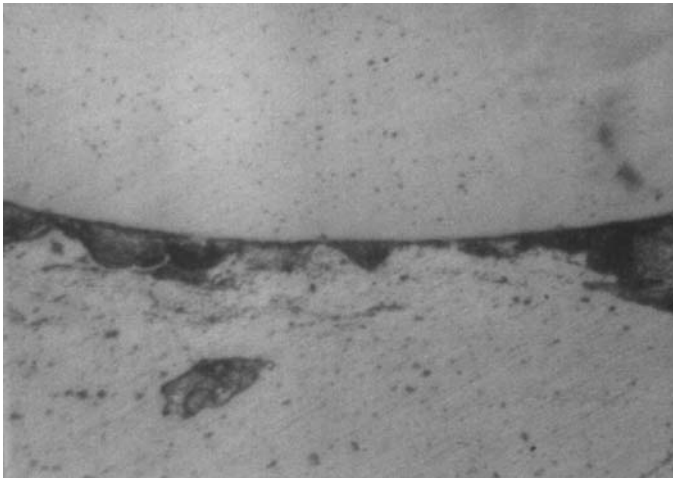

Figure 7.9 Aluminum alloys can either corrode during etching when manufacturing the microstructure test piece or some oxide layers can destroy the surface to be photographed when cutting the samples. For example, the joint presented here (enlarged 340 \times) is perfect, though the photo suggests the joint is a total reject.

However, the hardness distribution could give important information about the quality of the joint and also describe the possible discontinuities from microwave point of view. The hardness profiles of the tested filter strip and the center pin are presented in Figure 7.10. It is obvious that the hardness of the pin will decrease some 15% due to the USW process.

Cost-effective mass-production of mechanical microwave filters requires the utilization of most modern manufacturing technologies. If there are some specified physical loading conditions to be met (e.g., for military purposes), it is more than likely that the conventional joining technologies are not good enough to ensure the required performance and mechanical properties. Some adhesives are excellent for joining, for example, semiconductors. Laser processing is flexible if we are not working with highly reflective or otherwise “difficult” materials. Ultrasonic welding is a modern tool for joining connectors, for example. However, to be honest, even though the search of USW parameters is a simple routine, there are still several requirements of accuracy to be met after the successful welding process. A comparison of the different joining technologies for CuBe-alloys is presented in Table 7.4.

7.5 Welded Joint Geometries of Microwave Cavity Resonators and Waveguides

The selection and combination of appropriate materials and manufacturing methods for metrology-grade microwave resonators can be improved by

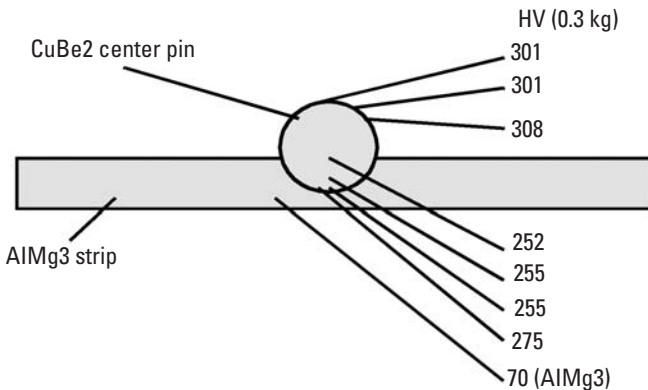

Figure 7.10 The hardness profile of the test piece. The hardness of the pin has decreased by 15% from its original value.

Table 7.4

A Comparison of Different Joining Technologies for Coaxial Connectors

Joining Technology	Manufacturability	Performance
CO ₂ laser	–	+
USW	–	+++
Nd:YAG laser	+	++++
Soldering	++	++
Glued joint	+	+++

utilizing an advanced design methodology and manufacturability analysis. These will enhance performance and long-term reliability and are often able to reduce cost as well. Typical interest areas include steel resonators both for Cs- or H-maser atomic standards and those operating as stand-alone devices in the millimeter wave region. New performance levels are feasible due to improved surface quality, stability, and the reduction of seam widths (e.g., by laser welding). A stepwise manufacturability analysis procedure points out solutions particularly for challenging airborne, sea or space platforms in the higher microwave bands. Here prototype specifications exceeding those of conventional copper cavities have been achieved. The loaded quality factor of a 15-GHz rectangular steel cavity approaching 400 in a 50- Ω system with a simultaneous tuning error below 0.1 MHz seems feasible. To illustrate the possibilities of laser welding or laser processing we discuss a military grade 15-GHz microwave cavity resonator assembly. For a specific frequency control application a very stable, well conducting and dimensionally precise structure was needed, capable of surviving also in a harsh military environment. Further design wishes were minimal attenuation in critical areas, magnetic shielding and the ability to withstand excess thermal power. Subaudio vibration and shocks were known to be encountered in this particular application.

The general requirements for a microwave resonator are based on electromagnetic wave propagation, transmission line theory and the electromagnetic properties of applied construction materials. Focus areas include impedance matching of the resonator and the 3-D field pattern and polarization characteristics. Naturally, maximum Q and its stability and the electric shielding performance of the selected construction are all very important issues in a military application. Imperfections in the cross sectional structure

of the resonator itself, misalignments, material dents, oxidation and nonperfect joints between sections can be reduced without adding the design or production time or cost.

Both the capabilities of manufacturability analysis, general laser processing and the suitability of steel for microwave work can be judged, for example, by manufacturing cavity resonators for various center frequencies and testing their radio frequency characteristics. Particularly interesting are their structural losses. In our case, a 15.0000-GHz rectangular cavity design operating in the TE_{mno} -mode was used. Two test samples were assembled, one as a conventional soldered copper construction and another from steel with laser welded joints. The basic structure is shown in Figure 7.11.

Various initial imperfections in the raw material and possible burrs or dents caused by the welding process will lower the resonator quality factor. They easily generate unwanted modes depending on their location, too. Dimensional uncertainties, particularly along the z -axis, change the center frequency.

Ideally, the cavity should have four walls along its longitude axis (z -axis), each of them perfectly conducting, perfectly flat and adjacent panels should be



Figure 7.11 The laser welded steel prototype is completely sealed except for the small coaxial SMA-type connector. The outside appearance of the test unit is of no technical importance. The rectangular cavity resonator has six conducting walls and a coaxial feed. The wave propagates and resonates along the z -axis. The detailed 3-D CAD model is presented on the attached CD-ROM [7].

at right angles against each other. This assures a correct propagation mode (usually of TE-type) in the cavity. For example, welding joints protruding inside the cavity will spoil the corners and induce unwanted modes, which usually decrease the quality factor Q . The effective surface conductivity might be changed as well. Another possible problem is the oxidation of the inner surface of the cavity due to welding. This drawback is hardly correctable later due to the completely closed construction. Further on, the length of the resonator must be an integer multiple of the half-wavelength or $\lambda/2$ with conductive plates at both ends. This defines a series resonant behavior, which shows an impedance minimum at the center frequency. A mechanical deviation will cause an immediate change in the resonance frequency.

The unloaded quality factor Q of the test resonators was found to be about 24,600 for a copper cavity and 8,600 for a stainless steel version. The laser welded steel prototype was measured with a microwave vector network analyzer (VNA). A typical result, presented as a Smith diagram, is shown in Figure 7.12. Based on this, we can compute the realistic Q -value either by

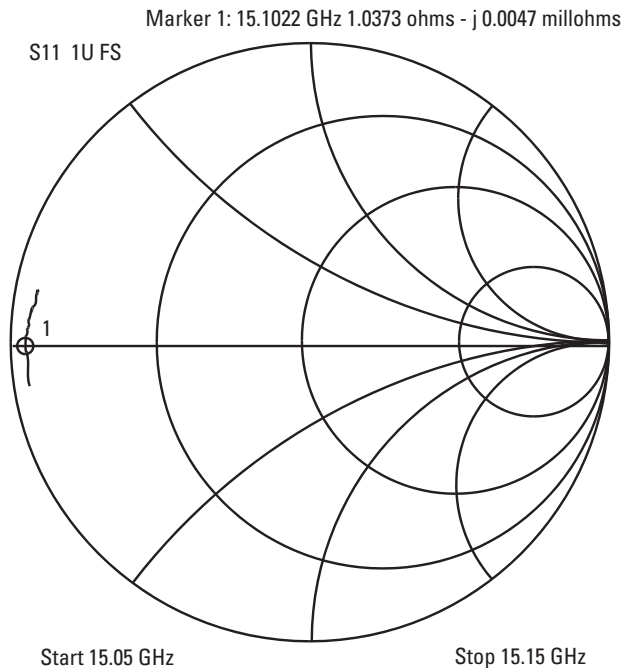

Figure 7.12 The steel resonator impedance near the center frequency. The loss resistance is about 1.2 and the 3-dB loaded bandwidth 62 MHz [7].

looking at the frequency difference between those points where the series resonant input impedance grows to 1.414 of its minimum or

$$Q = \frac{\omega}{2 \cdot R} \cdot \frac{X}{\omega} \quad (7.1)$$

where ω is the angular frequency and the resonator is assumed to have an input impedance $Z_{in} = R + j X$. A narrow 100-MHz sweep with as many points as possible is needed due to the sharp resonance. The measured, loaded Q varies between 290 and 360, depending on the frequency span and evaluation procedure. It seems thus, that the material selection was successful and steel, particularly if laser welded, can be used effectively for small-sized microwave components.

The prototype resonator length was somewhat, about 0.5 mm, shorter than designed. This is readily visible in Figure 7.13 where the resonance frequency is plotted as a function of z -axis dimension d . Unfortunately, the coupling arrangement to the resonator E -field is dimensioned for 15.0000 GHz and thus optimum performance cannot be achieved. The effects of the coupling arrangement are discussed further in Section 2.4.4.

Actually, it turned out that the applied microwave technique is the only feasible and practical, nondestructive method for the accurate measurement of the resonator's internal length. With another 50 μm longer feed rod, the center frequency was found to be 15.0710 GHz. The resonance frequency could be measured (using the VNA as such) with an uncertainty smaller than 0.1 MHz, which equals a dimensional error of 0.5 μm , see Figure 7.13. Further tests with an elevated temperature showed that the resonance frequency of the steel prototype decreases 23 kHz/degree.

7.5.1 Practical Welding Instructions for Cavity Resonators and Waveguides

As proven before, a cross section of a cavity resonator or a waveguide must be symmetrical, the opposite walls must be parallel, all corners should be sharp edged and walls that are joined together must be perpendicular (see Figure 7.14). It is difficult to utilize any standardized cold formed profiles, cold pressed enclosures or cast products because they all have fillets or chamfers characteristic for each manufacturing technology. Due to sealing problems also milled constructions are difficult to use. In our study, a laser welded construction was tested and to make laser processing more cost effective it was also used for cutting the sheet metal parts and tuning coaxial transitions as well.

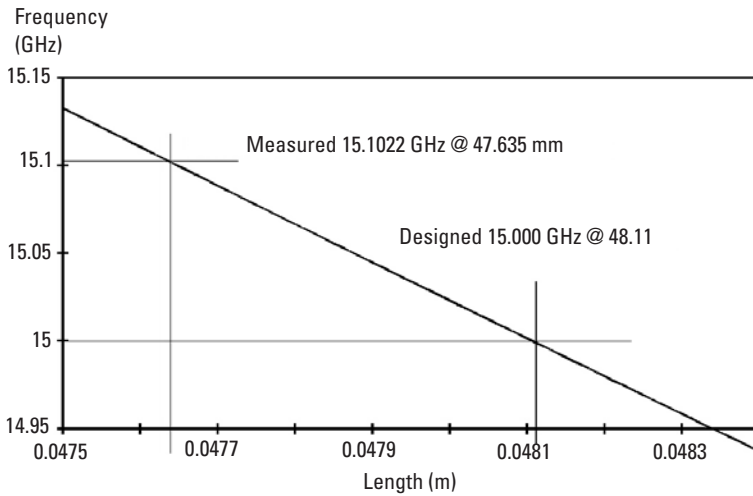

Figure 7.13 The steel prototype resonator turned out to be $475 \mu\text{m}$ shorter than designed. This shifts the center frequency nearly 102.2 MHz upwards [7].

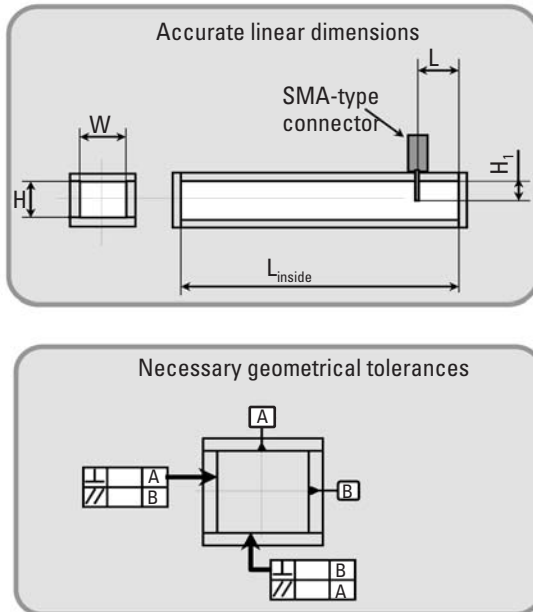

Figure 7.14 A schematic presentation, which illustrates the required geometrical tolerances and the most important accurate linear dimensions of an ideal cavity resonator.

Quite interesting results are shown in Figure 7.15. Both types of edge-flanged joints (either edge weld or seam weld) are relatively easy for welding. Some disadvantages can be found from total manufacturability analysis (bending of the flanges) but the performance of a fillet or a waveguide would have been poor due to rounded corners inside the cavity. The square butt weld with corner joints would give a bit better performance, but we can still assume that there is a possibility to get some spurs or penetration of the weld inside the cavity. Of course more exact tolerancing is necessary and both manufacturability and weldability properties are decreasing. If we then have a look into the fillet weld construction were T-joints are used we can easily notice that the manufacturability aspect of sheet metal parts can easily be taken into account and also weldability is relatively acceptable. Unfortunately we have a risk that there is a tiny pocket between the walls, which will disturb the microwave function of the cavity. To ensure the best performance of the product we do need seam welded corner joints even though the construction is a challenge for laser welding. This example shows what kind of compromises typically must be accepted when trying to design welded microwave constructions. We must rethink the traditional weldability and manufacturability aspects. In Table 7.5, we have listed the most serious welding imperfections that will surely decrease the performance of a resonator.

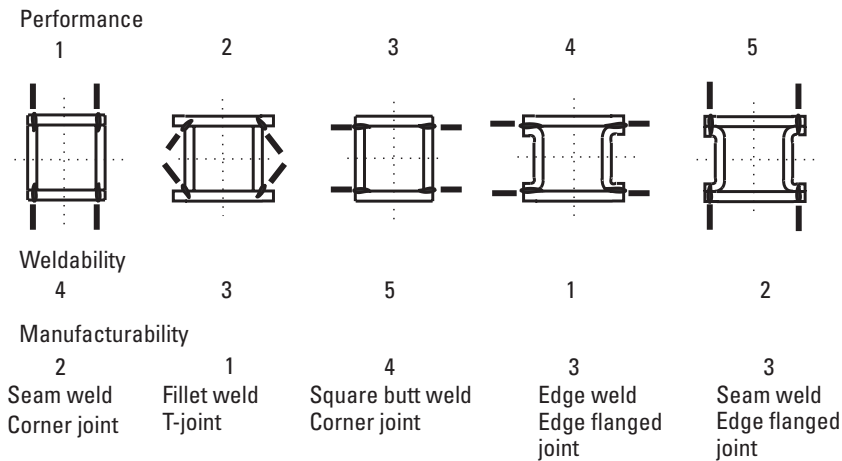

Figure 7.15 Comparison of different joint geometries for a cavity resonator or a waveguide. If the best performance is required some compromises must be accepted in manufacturability and weldability aspects [8, 9].

Table 7.5

List of Main Welding Imperfections That Can Cause Deterioration of Resonator Performance

Burrs of the weld pool inside the resonator
Lack of fusion
Burrs due to full penetration welds
Dents due to incomplete penetration
Deformations of the cross section of the resonator due to high heat input
Changes of the material properties due to enlarged HAZ

In Chapter 1, we have already studied what happens at welding discontinuities where, for example, a rectangular part has dimensional nonidealities. The presented theory was related to common transmission line theory. The most important result is that if a line is not terminated to a suitable load or its own characteristic impedance varies along the z -direction, part of the energy originally propagating towards the positive z -direction will be reflected back. The same will happen if, along a uniform line, structural or dimensional discontinuities occur, (e.g., the cross section is changed, the alignment of individual sections is not perfect, or the surface material (inner) is changed).

7.6 Welded Radiating Elements of Patch Antennas

In this chapter the design and construction of a tower mounted radio frequency transmitter assembly, carried out by a joint group of electronics and mechanics people, demonstrates the capabilities of an appropriate weldability analysis. The design project included both the analysis of enclosure manufacturing and further the design of the subassembly mounting on top of the tower. This system requires a very stable, well conducting and light-weight assembly structure capable of surviving also in a highly corrosive environment. Intense electromagnetic fields were known to exist near the equipment. The mechanics was to provide not only shielding but also correctly dimensioned internal microwave impedances and paths for thermal flow. The welding process should not leave any residues inside the enclosures sealed for life.

Particularly electronically scanning radar and various microwave link devices require antenna matrices capable of handling high RF power levels.

The losses must be minimal and practically no reflected power over up to octave bandwidths should exist. Based on their inherent low-loss characteristics, all metal patch array constructions using air as a dielectric seem attractive. They readily provide a built-in supporting structure as well, unlike various printed circuit board designs. The main problem in the application of sheet metal parts for this purpose is the need to find a cost-effective, repeatable and reliable joining and assembling technology. They are needed for the fastening of individual radiating elements to the associated ground plane, which in the general case is highly curved. Of special concern is the unwanted variation of a separate element's input impedance as a function of the mounting scheme. There is also an interest to adjust the material properties. They lead to the desired RF behavior but must also fulfill the possible mechanical strength and manufacturability requirements. This implies the need for methods using steel variants. In some applications, the possibility of integrating, for example, filters or power dividers as a built-in module of the antenna is highly desirable although today they can be (and in most cases are) of Teflon-based origin.

In this chapter we use a quarter wave L-band patch element made of aluminum or steel as an example. See Figure 7.16 for a schematic view of the cross section. Also some results dealing with complete planar and cylindrical prototype arrays of 4×4 and 8×4 elements are presented. These applications have shown that the joint which is used to make the short circuit between the ground plane and the radiating element is hardly reproducible to the required level of RF performance (e.g., with conventional, unoptimized welding processes, screws and nut,s or with soft soldering). This particularly occurs if variations in material characteristics are also included. Both the element dimensions (after assembly), mutual alignments within a complete array, but most notably, the electrical length and the contact impedance

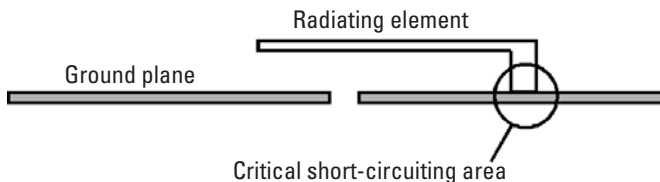

Figure 7.16 The basic geometry of the quarter wave patch antenna is simple. The only problematic points are the coupling of the feed pin and the short circuit near the element edge. The wideband nature forces the air gap to be a substantial fraction of the wavelength, which complicates the mechanical integrity of the element [10].

are of major concern. They all depend on the joining technology. Three typical test configurations are illustrated in Figure 7.17, which shows a primitive but easy screw-joint, a laser welded high-tech steel prototype, and the result from the TOX-pressing process. The TOX-joining technique joins different materials by means of an upsetting-pressing process. The joining process is based purely on displacing and forming of the materials. The surface of the materials are not damaged during the process [11].

In general, a safe operation of electronics in a severe environment relies mostly on the survivability of respective mechanical parts. Ways of increasing this compatibility are often neglected obviously due to the lack of knowledge or optimized design principles. Much additional cost is accumulated or wanted performance lost just due to inadequate understanding (e.g., of joining capabilities). A great impact comes from the designing methodology itself. In the case of mechanical functions of an electronic device the main problem can be simplified to be in defining their correct manufacturing process. The design for volume production of water, gas and radiation tight metallic enclosures for electronic modules includes the weldability of applied materials, structural weldability and the choice of proper welding processes and their mutual order.

When trying to achieve both a number of radio frequency and mechanical goals simultaneously at low cost and in a difficult environment, the optimum dimensioning and geometrical tolerances, surface roughness and other flaws, materials and particularly joining parameters must be defined. They describe the processes qualitatively. A fluent cooperation between the designer and manufacturer is needed. Different methods are compared according to their adequacy with respect to the production volume. Also recurrence, cost, the level of standardization and the use of modular construction are taken into account.

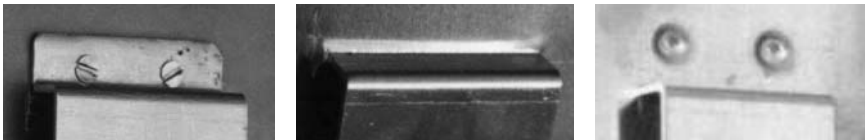

Figure 7.17 Some evaluated joining technologies for the element edge include a simple twin machine screw design (left), a laser-welded steel construction (center), and a press (TOX) joint (right) [10].

The radio frequency performance of an S-band quarter wave patch antenna element depends to a great extent on the selected materials, mounting tolerances of the individual components and finally on the selected joining process. The basic construction is demonstrated in Figure 7.16 showing the radiating element, associated coupling pin and the ground plane. In the general case, a ground plane can be an integral part of a vehicle or another construction, too. The width and length of the radiating plate are both exactly one fourth of the free space wavelength but the position of the coupling pin as measured from the short circuiting joint or from the open edge is highly critical, as is the resultant contact impedance at the short circuit. The detailed manufacturing documents and illustrative 3-D CAD models of the antenna construction are presented on the attached CD-ROM.

Several material and process combinations were tested and measured with the VNA four-port method. To get an overall picture of the possibilities of modern joining technologies and to get objective comparison data for choosing the best welding process we have tested the following joining technologies: TIG welding, MIG/MAG welding, CO₂ and Nd:YAG laser welding, spot welding, plasma arc welding, submerged plasma arc welding, riveting, bolted joints, soldering, clinching, and glued joints. The optimum reference performance was initially obtained with a tunable design having a bolt-jointed radiating element and a specially constructed groove for the coupling pin mechanism. Figure 7.18 demonstrates the effects of the dimensional uncertainties on the input impedance of the patch element. The design marked B is the best one because its distance from the diagram center is the smallest. Additionally, A is acceptable but C shows a clear mistuning. The reader should note that the Smith chart has here been enlarged to cover only the S₁₁ values up to 0.5.

After initial trials, several samples were manufactured by using both aluminum and steel and a number of welding technologies. The first observation, being particularly true for TIG processes is the high deviation of the impedance curve from the one obtained experimentally with the bolt-jointed design. This was found to be caused by the changes in the material properties near the short circuit due to the high temperature. The second general observation is that aluminum gives worse performance than steel with most welding technologies. This is further clarified in Figure 7.19, where the overall displacement of the recordings is due to the unexpected mistuning.

The laser welded short circuit at the upper end of the radiating element gives the most stable impedance characteristic for the patch antenna. The difference between various TIG technologies is small and the trials with spot

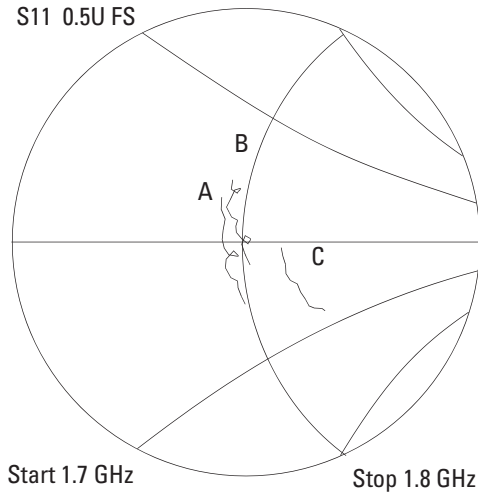

Figure 7.18 The dimensional uncertainties have a major role in defining the impedance of a patch element. Here, A has been obtained with feed point displacement of 11.24 mm, B with 12.94 mm, and C with 8.80 mm. However, B has a steel ground plane, whereas others have an aluminum one [12].

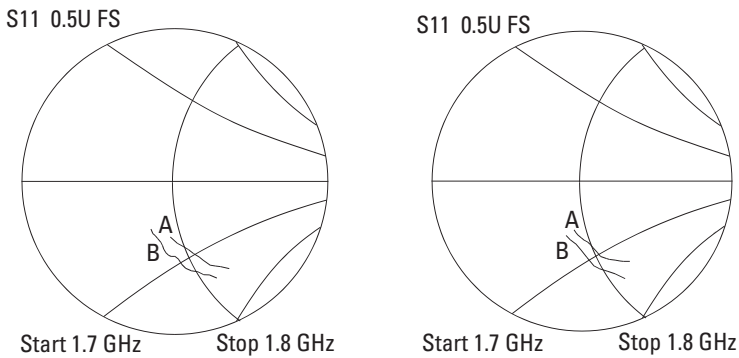

Figure 7.19 The effect of conducting material is evident and does not depend on the process. Curve A, which is close to the chart center and thus indicates better impedance matching, has been measured with an Al patch element and B, which has a greater distance to the $50\text{-}\Omega$ point with a steel unit. The left diagram is of reverse-side-only, TIG-welded samples. We get the one at the right, if both front and reverse sides have been welded [12,13].

welding gave generally the worst results of all. Figure 7.20 summarizes the key findings of this test. It seems possible that the more predictable tuning

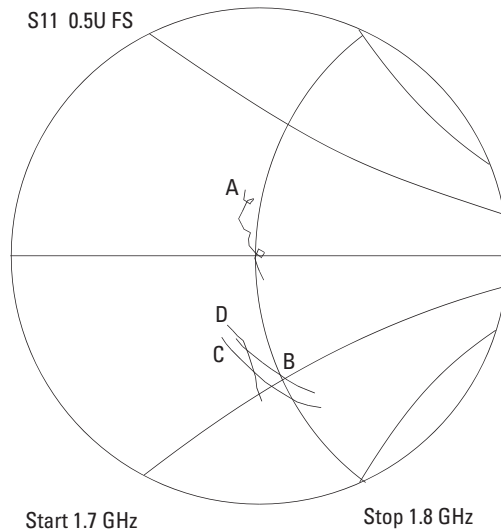

Figure 7.20 The welding process has its contribution to the impedance characteristics as well. A is the optimum reference curve obtained with a tunable bolt-jointed antenna, B is a laser welded device, C a spot welded device, and D a TIG sample. All units are made of steel [12].

behavior of laser welded radiating elements is due to the smaller heat input, which further limits the volume where the material parameters (e.g., electrical conductivity) are changed.

The effort of finding an optimum position for the contact point of the coaxial connector before welding by using a screw mechanism was not successful, as can be seen in Figures 7.21 and 7.22. The less obvious reason was found to be the superior electrical contact obtained with laser (series resistance only 71.95 m Ω) as compared to adjustable design (686.55 m Ω). This can be seen as an overall shift of the measured curve to the left. The series resistance values were measured with a HP 3458A 8½ digit multimeter.

It is obvious, like shown with this antenna application, that weldability analysis should be applied in the very first prototype phase. This enables the use of modern production methods and helps to avoid hard-to-fix mistakes. Improvements are based on correct joining technologies, here particularly laser beam welding, surface tolerances, alignment, coatings or the method itself. Accurate information about the electrical behavior of materials commonly applied in machine industry is further needed.

In this patch antenna case example we could not find an optimum position for the contact point of the coaxial connector before welding by

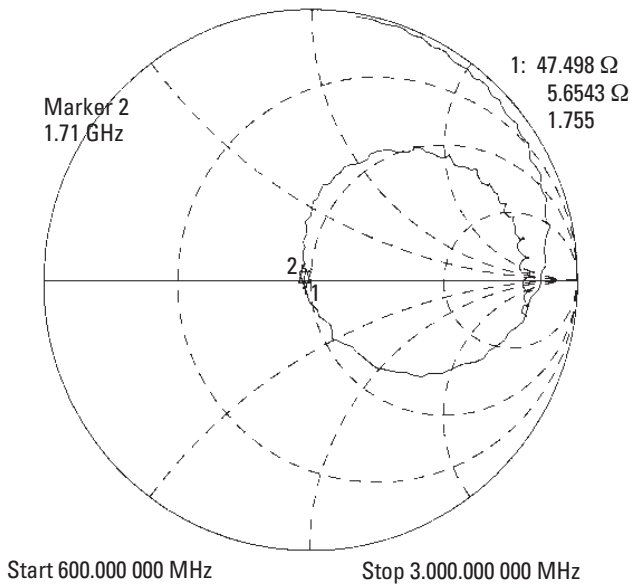

Figure 7.21 The adjustable patch antenna prototype could be tuned almost perfectly [12].

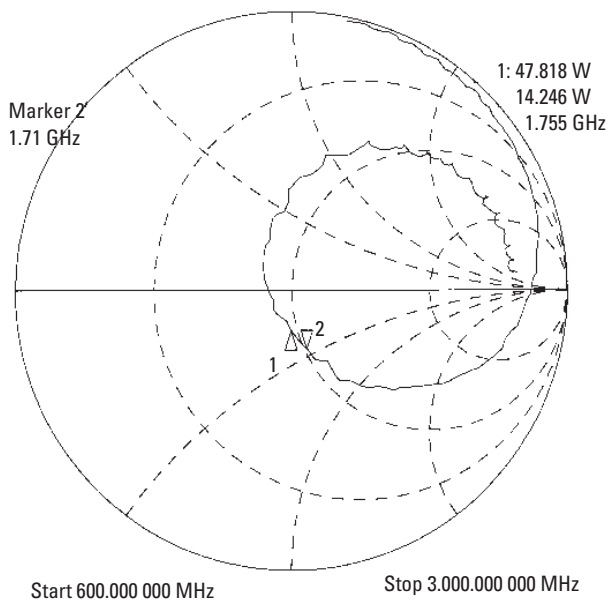

Figure 7.22 The laser welded antenna version did not perform expectedly with similar adjustments [12].

using a traditional screw adjusting mechanism. The less obvious reason was found to be the superior electrical contact obtained with laser compared to the adjustable design. This result has proved to be of high interest when designing industrial laser welded antenna applications. Another problem was related to the improper mechanical alignment tolerances of the element.

If conventional, work-shop grade MIG welding is tried, the observed variation from sample to sample in the real part of the element input impedance exceeds 10%. This is obviously caused partly by the uncertainties of weld placement (only provisional jigs) and seam size. Other issues are the weld penetration and the heat affected zone (HAZ) dimensions, which very likely change the intrinsic conductivity of the material above 1 GHz. Tedious comparison measurements with a high resolution DC micro-ohm meter support this conclusion, too. A similar effect is visible in the joint between the feeding conductor and the radiating square plate. From the process point-of-view, a barely measurable difference can be noticed between a spot welded construction or a TOX joint as can be seen in Figure 7.23, where

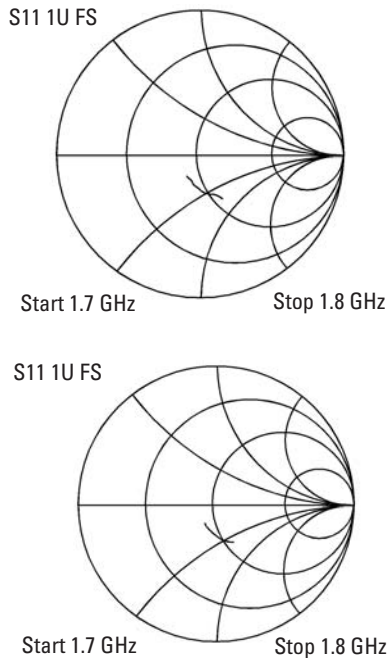

Figure 7.23 A TOX-joined aluminum element (top) shows a capacitive nature and the position of the short is too far from the design value. Similar performance is obtained with a spot welded steel construction (bottom) [10].

both selected schemes produce a far from acceptable result. It is noteworthy that the initial design values for feed position were not valid at all for either of these joining technologies.

A carefully adjusted laser welding technique, selected according to the applied materials (e.g., aluminum or steel), has been found reasonable for this specific joining task. The reproducibility of S_{11} is better than 1% from element to element. Due to the reasonable heat input, the process-based deformations of patch shape and alignment can be kept within acceptable limits (e.g., less than 500 μm within 160 mm) all over the processed area of the matrix. High power operation ($S_{11} < 0.15$) seems feasible with the proposed configuration over a 100-MHz (10% relative) bandwidth. Two typical results are shown in Figure 7.24 both for a steel assembly and for an all-aluminum construction. Also, conductive glue gives a satisfactory electrical performance (Figure 7.25) but has evident cost limitations. The theoretical

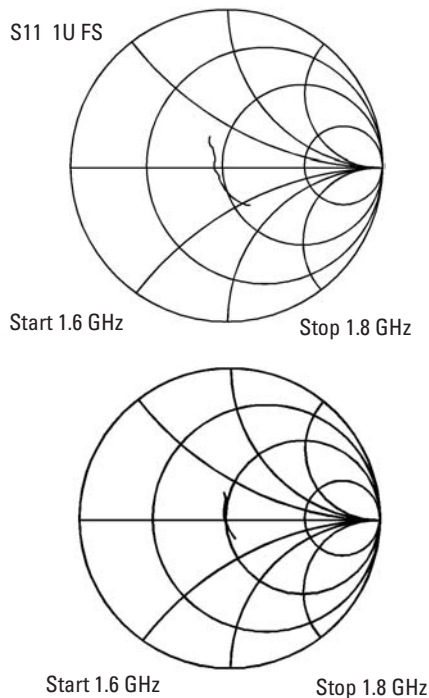

Figure 7.24 Laser seam weld provides an accurate short circuit position regardless of material. The aluminum sample (top) suffered from excessive beam power, which caused some deformation of the L-shaped radiating element. The steel prototype (bottom) gives a quite perfect impedance match [10].

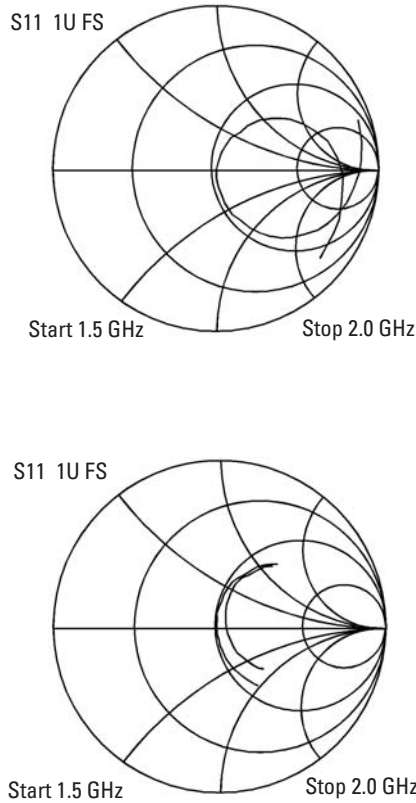

Figure 7.25 Conductive glue was used experimentally for the joining of an aluminum patch (top). The theoretical feed pin position worked also in practice. When the MIG parameters are carefully adjusted and the aluminum alloy chosen accordingly (bottom), very good results over 100 MHz can be achieved [10].

feed position gives reasonable results in real life, too, because there are hardly any thermal deformations involved.

Boosted by these observations, the MIG welding parameters and the fixturing arrangements including the jigs have been reconsidered. After a careful study and a fine tuning of the process parameters, quite comparable or still better performance seems achievable as is demonstrated in Figure 7.25 for a complete 4×4 array where the only differences in element S_{11} were caused by the (intentional) misalignment of the feed point by 1.5 mm from the calculated position.

The redesigned fixturing system enables welding without tack welds. Sheet metal parts and assembly holes are laser processed to ensure the

required tolerance grade for the positioning of the radiating elements. The welding head is mechanized to stabilize the quality. To overcome the difficulties in maintaining the geometrical tolerances of the assembled matrix a totally new sandwich-like construction has been tested. It reduces deformations due to the combination of a sheet aluminum base plate and tensions generated during welding. Besides providing the required stiffness the suggested design is able to incorporate as an integrated element also the planar feed network and the all-metal high power bandpass filters as a stripline design. Very successful results regarding the shape have been obtained also with a tailored assembly jig set-up, which seems to even out some of the thermal gradients.

A close-up of this MIG weld is visible in Figure 7.26, and the corresponding welding parameters are presented in Table 7.6.

The complete 4×4 array gives some tuning possibilities also if less successful element impedance values are available. This is due to the additional degrees of freedom within the feed network. Laser processed all-aluminum stripline parts inside a sandwich construction produce a reasonable total impedance together with the TOX-joined patch elements as is visible in Figure 7.27. The masking effects of mutual couplings between subarrays

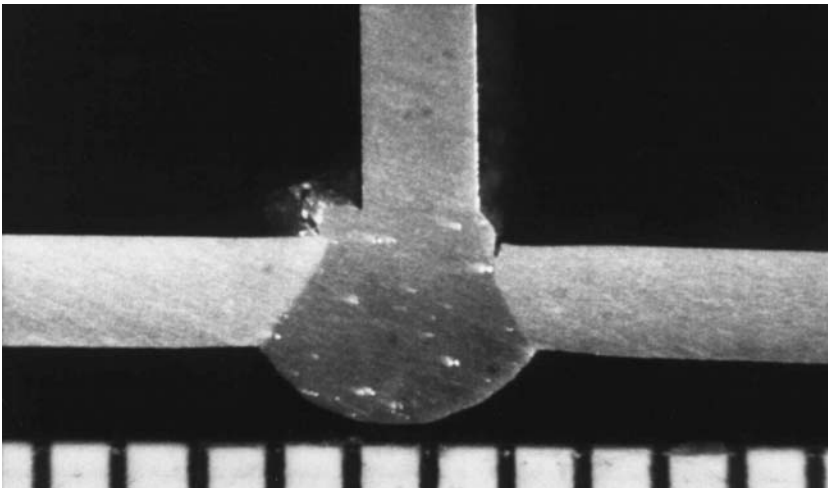

Figure 7.26 A close-up view of the optimized MIG welding result. The penetration is sufficient, however some burrs can be seen in the opposite side of the weld. Slight gas pores in the weld or tiny misalignment of the arc (to the left) do not essentially affect the reliability of the weld but should be taken into account when comparing the electrical properties of the joint [10].

Table 7.6
MIG-Welding Specifications for AlMg3

Parent material	Thickness	1.5 mm
	Material	AlMg3
	Preparation	Laser
Consumables	Diameter	0.8 mm
	Classification	AWS: ER 5356
Welding parameters	Current	100A
	Voltage	13V
	Distance	4.5 mm
	Speed	150 cm/min
	Shielding gas	Argon
	Torch angle	+ 8(P)

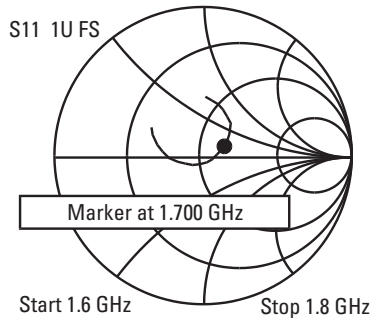

Figure 7.27 A complete TOX-joined subarray shows a return loss not worse than 13 dB over the whole RX band. A linear feed network is utilized. When carefully tuned the array would presumably give about 20 dB of RL [10].

were found to be below 24 dB. The power handling capability of the constructed prototype array is currently limited only by the coaxial feeder cable.

The maximum heat input of each technology must be discussed when comparing welding processes. Here an analysis is vital due to the relative large and thin ground plane and $n \times m$ T-joints of the radiating elements. At first we noticed that according to radio frequency dimensioning, the elements should be placed at the most critical positions regarding heat input.

This means that is relatively difficult to control the deformations and distortions. We already saw that the antenna is tuned by adjusting the position of the coupling pin. The other tuning parameters of the antenna depend on material properties, geometrical uncertainties, weld geometry and on the metallurgical properties of the joint. The influence of deformations should be added to these tuning parameters (see Figure 7.28). The computer simulation in Figure 7.29 shows that the most critical areas regarding the performance of the single radiating element are the start and the end points of the joint and the accurate positioning of the feeding point of the radiating element. These results give the real indicates to the practical welding arrangements—no imperfections are allowed near the start or the end of the weld.

To fully understand the importance of heat input control during welding, let us list the most important mechanical properties of the patch antenna element required for optimum microwave performance:

- Surfaces of the radiating elements and the ground plane should be parallel.
- The shorter sides of the radiating elements should be perpendicular to the ground plane.
- The positioning tolerances of the coupling pin should be $\lambda/320$, or even $\lambda/640$.
- Hardly any welding imperfections are allowed in the joint between the radiating elements and the ground plane.

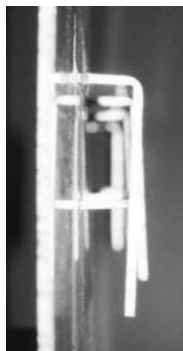

Figure 7.28 A cut section of one radiating element (the corresponding CAD model is presented on the attached CD-ROM), which is a part of a final planar $n \times m$ antenna matrix. The joint between the L-geometry (width 30 to 80 mm) and the ground plane is interesting. The photo shows the deformations in each element due to uncontrolled welding [14].

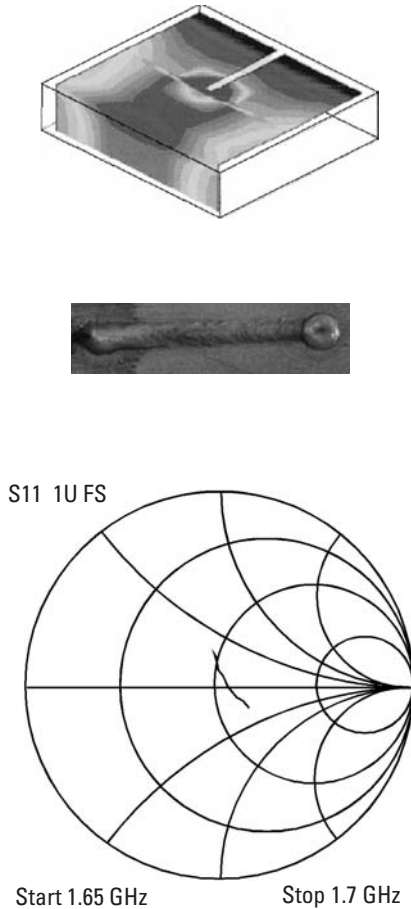

Figure 7.29 The simulated microwave current distribution reveals that most of the radio frequency energy will flow through the patch edges, marked with the contour curves. The areas in the middle of the weld have a current density 10 to 20 dB below the maximum. The photo of the weld itself shows an error on the back of the ground plane. The fault detunes the resonating feed as seen on the Smith chart [14].

- The mechanical and metallurgical properties and dimensions of the radiating elements should be similar.

In practice, it is impossible to meet all these requirements. At least absolute values are hard to gain. As an illustrative example we present two curves in Figures 7.30 and 7.31, which show the effect of improper element

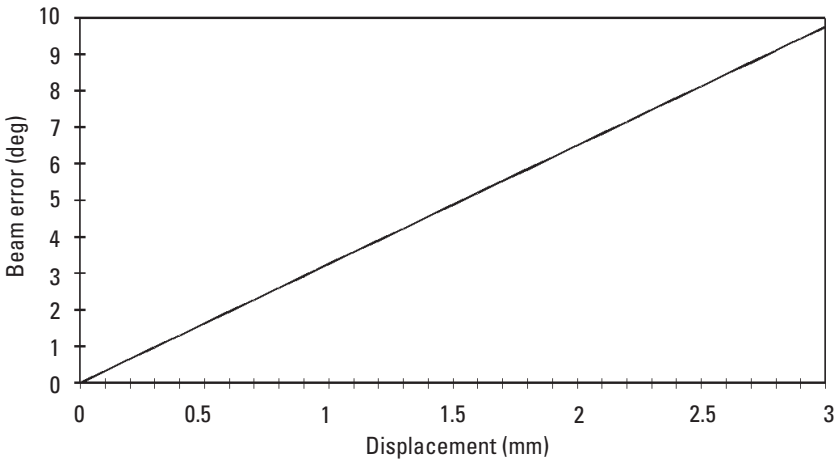

Figure 7.30 Main beam maximum misalignment due to subarray displacement [15].

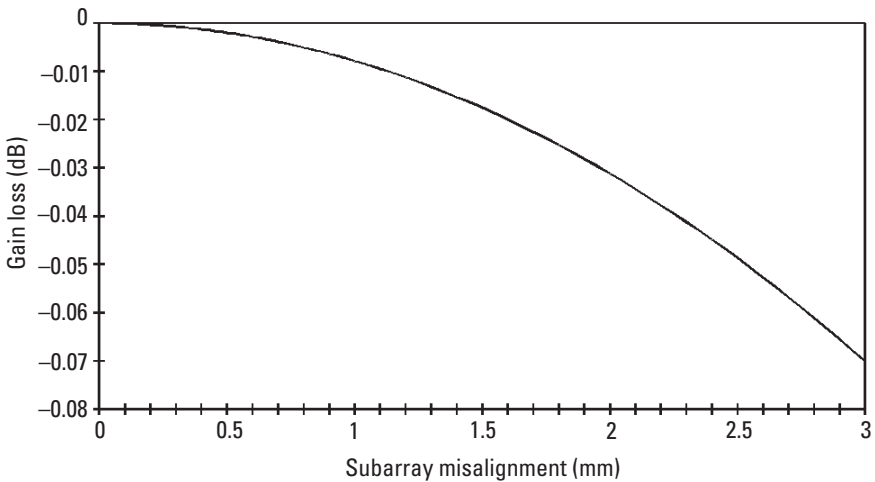

Figure 7.31 Gain loss due to subarray misalignment is normally a less important problem [15].

location. From Figure 7.30 it is easy to conclude the importance of any manufacturing tolerances (effects on the pattern direction) and Figure 7.31 illustrates the far less important gain losses due to subarray misalignment. For example, efforts to ensure tight sheet component tolerances by laser cutting can be wasted due to improper welding. The entity can be also spoiled

by uncontrolled welding deformations, which could be avoided by a properly chosen heat treatment.

Figures 7.30 and 7.31 indicate that an acceptable performance level of the antenna cannot be reached even if tolerances for practical welding work according to EN-ISO 13920 class A are required. In addition to this, we must set specific geometrical and dimensional tolerances for the ground plane, elements and especially regarding their positioning during the assembly.

Post and preheat treatments were used with different welding processes to improve the straightness of the ground plane and the parallelism between patch elements and the ground plane.

We have modeled the possible welding deformations of the ground plane due to varying heat input of different welding processes. The results are visualized in Figure 7.32. After having the final mechanical geometry of the antenna and the possible welding imperfections between the radiating element and the ground plane, the actual pattern can be simulated and the performance can be virtually checked. If these results are satisfying we are ready to compose the final welding instructions for the manufacturer.

7.7 A Comparison of Welding Processes for Encapsulating Electronics

Most commercially available semiconductor components are not able to survive on their own in a hostile application environment with changes in temperature, humidity, pressure, vibration and contamination of dust, sand, and

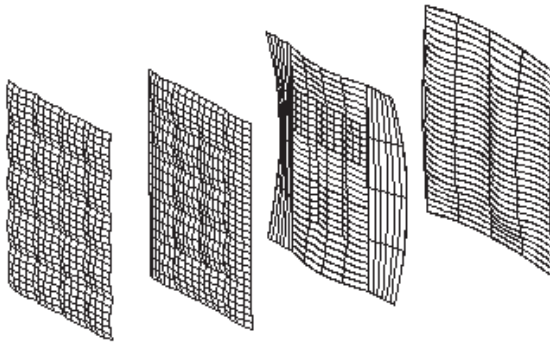

Figure 7.32 The expected deformations of the ground plane due to welding heat input for different configurations and appropriate heat treatments (3-D models from right to left) [15].

dirt. The situation does not change a lot whether the individual parts are just as they left their home factory or have been later assembled on a circuit board. Most high speed devices and systems and particularly those used for radio frequency purposes further require a completely conducting enclosure. It reduces the mutual electromagnetic couplings between the electronic circuit and the hostile outside world. From the mechanical designer's point of view, the obvious question is how to encapsulate the electronics in the most effective way with minimal costs.

The traditionally applied enclosure technologies are alternatively based on die-cast boxes of less favorable size, milled task-specific brass or aluminum designs. These break the budget in volume production and provide us with exaggerated wall thickness or need a superfluous use of conducting adhesives. None of these methods gives a true protection against a long-term exposure to humidity due to the inadequate sealing properties. Particularly semiconductors in a plastic case are not hermetic, that is, they slowly absorb contaminants from outside if a completely gas tight enclosure is not available. Various soldering practices cannot be used because most electronic modules do not withstand more than about 200 degrees for 5 to 10 seconds and because soldering leaves small amounts of corrosive particles also inside the joint. Arc welding is out of question due to its destructive electromagnetic radiation.

Laser beam welding—and even wider laser processing—provides an attractive alternative for the encapsulation because of the relatively low heat production outside the joint area, ability to produce a gas tight seam, the very small residual burrs on the unprocessed side of a metal surface and the small pointing uncertainty in volume production. The cutting capabilities can be applied to simultaneously form, for example, required connecting paths or for the fine tuning of resonator lengths. Of particular interest is the suitability of laser for thin metal sheets of dissimilar material. These reduce weight and also provide possibilities for increasing the mechanical integration of modules. The use of multilayer sandwich designs is encouraged, too.

Laser processing improves the reliability of the sealing of the encapsulations and gives cost and functional advantages as well. The solutions for encapsulating problems can be easily applied to typical microwave geometries.

7.7.1 Advantages of Laser Welded Sealing

Reliability aspects [16]:

A welded encapsulation has the potential for greater reliability, compared with solder sealing, for the following reasons:

- There is no chance of loose solder balls being trapped within the package. This is of concern especially when particle impact noise detection (PIND) testing is required.
- No flux is used for sealing. Even in careful soldering operations some flux is forever sealed inside the package. Because a mildly activated (RMA) flux is usually necessary to ensure wetting, there may be concern about long-term contamination in a solder-sealed unit.
- Unlike solder sealing where the internal parts approach solder-melt temperature, the heat applied by the laser is highly localized and of short duration, which means that the bulk of the unit remains cool.
- Laser sealing, being an automated process, provides a joint of closely controlled depth and width. It cannot cause anything analogous to a “cold solder joint.”
- Mounting a solder-sealed device runs some risk of unintentional reflow of the solder and consequent loss of hermeticity.

With laser processing also some cost and functional advantages can be achieved:

- There is no need to provide the inside corner of the encapsulation for a solder fillet, which means that there is more internal height of the package to be utilized.
- The external appearance is trimmer and visual inspection is easier.
- The performance increases (e.g., in microwave applications) due to better quality.

People dealing with different encapsulating applications and, for example, microwave components have collected several requirement lists to help the design project. The same problem comes up: Which is the way to define the manufacturing aspects most cost-effectively? If the requirement list has a demand for a specific manufacturing process it will cause many boundary conditions for other properties. However, if the manufacturing aspects are totally left away from the requirement list and if the manufacturability analysis is the last step of the process, it is probable that at least one iterative redesign cycle is needed [17]. The third possibility is to initially select the manufacturing method and adapt the other requirements with it. This can't satisfy the functional requirements and is therefore impossible. It is necessary to recognize the most cost-effective manufacturing process in the early stages of a design process and after that guide the design to satisfy both the functional requirements and

manufacturability aspects. This approach prevents time consuming redesigns. The same principles, which can be utilized for manufacturing encapsulations, can be at least partially applied in many microwave components as well. And vice versa, some general requirements of microwave mechanics will lead to consider the different solutions of encapsulating problems.

On the other hand, it is typical for microwave mechanics that “an encapsulation” has also other functional purposes than just being a housing for tiny electronic components. The enclosure might cover, for example, some IC chips and a microstrip circuit board and different kinds of connectors can be used. Possibilities include typical solder pins on the bottom and a coaxial connector on the sidewall of the housing.

The use of ultrasonic welding is an excellent solution for the performance and functional aspects of the enclosure. However, each new geometry and material pair needs new welding arrangements which means that to be cost-effective relative large series must be manufactured. In case of small production series it might be useful to compare other advanced encapsulation technologies. One alternative is ceramic packaging based on the lamination of fully fired ceramics by a set of proprietary glass compounds and compatible metallizations. The use of vacuum or nitrogen filled encapsulations might also be considered.

A simple microwave circuit board was constructed for the necessary performance studies of the welded enclosure (see Figure 7.33). The design is based on the MiniCircuits VNA-25 chip, which is a broadband amplifier

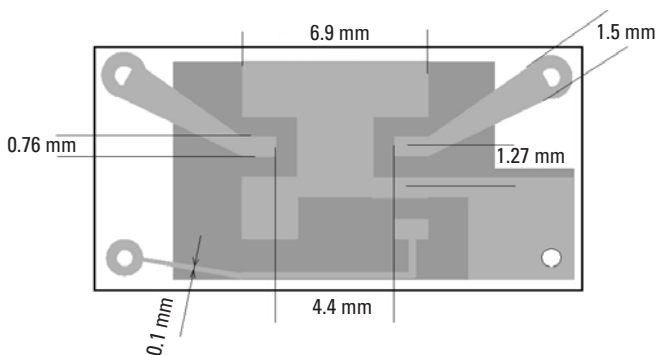

Figure 7.33 The lay-out of the printed circuit board which was used for testing the characteristics of the welded enclosures. Bottom ground plane (made of copper) is shown in dark gray. Dimensions are selected according to the enclosure and its feed-throughs. Additional data is available from *Mini Circuits RF/IF Designer's Guide DG-2002*, pp. 56-57 and 141.

covering frequencies from 500 MHz to about 2.5 GHz (manufacturer data). This choice fulfils the following requirements:

- Relatively low sample cost for volume testing, possibly destructive as well;
- Active circuit, which makes tests of EMC easier;
- Small size combined with some complexity to have a challenge for the enclosure;
- Favorable pin configuration whereby a simple circuit board is sufficient;
- Plastic case, which leaves most of protective, measures to the enclosure.

Initially, two reference units were assembled. One was just an off-the-self die-cast aluminum box and the second a milled, fit-to-size design. These samples were measured for their radio frequency performance in a completely coaxial set-up. Full two-port recordings were done with a calibrated vector network analyzer and the results were used as a basis for further comparisons.

The actual operating bandwidth turned out to be limited to about 2.4 GHz. Maximum gain was obtained at 1.65 GHz and it exceeded 25 dB. Both input return loss and gain showed an abrupt change at 1.8 GHz, which might be due to a less fortunate connector geometry. The input matching was relatively bad across the entire operating range but this was known to be typical of VNA amplifiers. Some spectrum measurements were performed as well. They gave the following parameters:

Harmonic distortion (600 MHz / -10 dBm): -24 dBc;

Harmonic distortion (1.5 GHz / -20 dBm): -49 dBc;

1 dB Compression (600 MHz): > -10 dBm input power;

Maximum intrinsic noise output: -45 dBm / 1.48 GHz / 10 kHz;

Two-tone (2 GHz / -10 dBm): -50 dBc;

Two-tone (1.5 GHz / -16 dBm): -35 dBc.

The following observations can already be made based on the two reference devices:

- The input reflection coefficient or S_{11} is an efficient test parameter for mechanical lay-out problems.

- The oversized die-cast box already had problems of its own origin due to the excessive coupling distances.
- The forward gain is almost saturated at 2 GHz, whereby EMC measurements should be done below that limit.

7.7.2 Projection Welding Application

Sometimes projection welding could be a cost-effective solution for sealing microwave enclosures. The less expensive equipment is advantageous when compared, for example, to ultrasonic welding. Also the welding speed is much higher. One typical application of projection welding is making joints between deep drawn enclosures and their steel covers. Normally the materials are very thin, below 0.3 mm. Some mechanical data for the characteristic case example is presented in Table 7.7.

For this particular application, the process consists of three sequential welding cycles presented in Figure 7.34.

In this case, because of the semiconductors involved, it is important to be able to control the thermal stress and the field strength of the electromagnetic shock. The heat input was quite acceptable, which can be concluded either from the macrophoto of the welded enclosure cross section (see Figure 7.35) or

Table 7.7

Mechanical Data for the Enclosure That Is Used as a Case Example of Projection Welding

Property	Value
Length	17.91 mm
Width	10.29 mm
Height	9.53 mm
Wall thickness	0.18 mm
Flange size	1.14 mm
Base material	C1008 AK (Cold rolled steel)
Temper	5
Surface treatment	Electroless nickel plating
Hardness	B55 max.
Alternative materials	Stainless steel 304 (annealed) or 233 pure nickel
Nearest standard model	E079-06CW

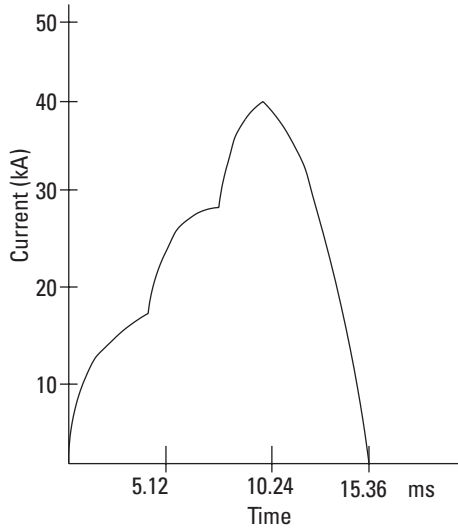

Figure 7.34 Used welding parameters as a function of time. Notice the three sequential welding cycles, each lasting about 4 ms.

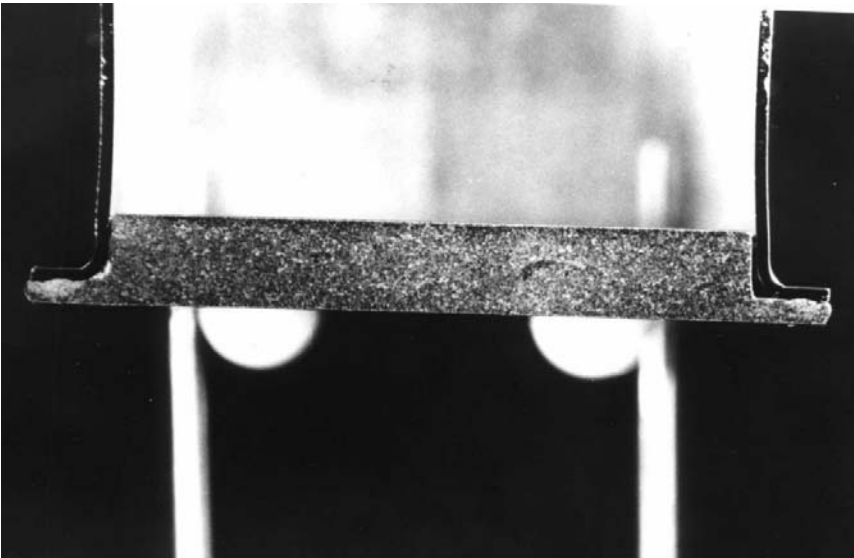

Figure 7.35 A cross section of the welded enclosure. The geometry is still acceptable. Even more twisting was noticed in some of the original nonwelded cover samples (the largest values of edgewise curvature were about 0.04 to 0.06 mm).

from the microstructure of the HAZ in Figure 7.36. The width of the HAZ is only about 0.1 to 0.2 mm.

The box itself is relatively easy to manufacture with almost any commercial deep drawn technology. Depending on the material, either cold drawn techniques or raised temperatures can be used. However, the cover itself is a sandwich structure, which includes the insulating elements for the vias and connecting pins. Also the special shape of the flange needs to be quite accurate for projection welding (see Figure 7.37). It is also essential to notice that due to electrically sturdy ground plane the component tends to act more like an oscillator than a proper amplifier—there is still need for some milled housings for these kind of products!

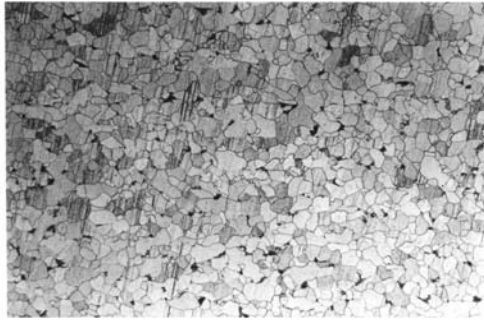

Figure 7.36 A microstructure photo (scaling $\times 100$) of the base material right under the cover. It is delightful that the changes due to welding are insignificant and the structure is mostly fine-grained perlite as desired.



Figure 7.37 A cross section of the corner of the welded housing. The basic geometry of the cover can easily be seen (scaling $\times 10$).

References

- [1] Kalpakjian, S., and S. Schmid, *Manufacturing Engineering and Technology*, New Jersey: Prentice-Hall Inc., 2000.
- [2] Wright, P. K., *21st Century Manufacturing*, New Jersey: Prentice-Hall Inc., 2001.
- [3] Eskelinen, H., "Computer Integrated Use of CAE and Microwave Mechanics Simulation in Welded Stripline Filter Design," *Computer Technology in Welding and Manufacturing*, TWI Ltd., Copenhagen, Denmark, Jun. 6–7, 2000.
- [4] Eskelinen, H., "Improving the Performance of Mechanical Microwave Subassemblies for Telecommunication Electronics," *Proc. of the 15th Int. Conference on Production Research (ICPR)*, University of Limerick, Ireland, Aug. 9–13, 1999, pp. 925–928.
- [5] Eskelinen, H., "A Look at Optimised Laser Processing for the Manufacturing of Passive Microwave Modules," *Proc. of the European Topical Congress on Technologies and Systems for Mobile and Wireless Applications*, München, Germany, Oct. 4–8, 1999, pp. 31–34.
- [6] VTT Manufacturing Technology (Yunfeng Yang), *Test Welding of Gold Coated Copper Wire on Aluminium Alloy Plate*, Research Report, VAL22-012422, Helsinki, Finland, May 11, 2001.
- [7] Eskelinen, H., "Suggestions for Finding Optimum Materials and Manufacturing Methods for Metallic Microwave Cavity Resonators," *Proc. of the 13th European Frequency and Time Forum and 1999 IEEE International Frequency Control Symposium*, Besancon, France, Apr. 13–16, 1999, pp. 567–672.
- [8] Eskelinen, H., "A Mathematical Tool for Optimising Limited Volume Laser Production of Passive Microwave Components," *Proc. of the Stimulating Manufacturing Excellence in Small and Medium Enterprises SMSSME-2000-Conference*, Coventry, England, Apr. 16–20, 2000, pp. 457–465.
- [9] Eskelinen, H., "Joining Instructions for Welded MW-Mechanics," *International Journal for the Joining of Materials*, Vol 13, No. 1, 2001, pp.12–16.
- [10] Eskelinen, H., and P. Eskelinen, "Assembly Considerations of High Power Wide-Band Patch Antenna Arrays," *Proc. of the Antennas and Propagation 2000-Conference*, Davos, Switzerland Apr. 9–14, 2000.
- [11] TOX-Joining Systems, TOX-Pressotechnik, www.tox-pressotechnik.de/e/products/joiningsystems, Apr. 11, 2002.
- [12] Eskelinen, H., "Weldability Issues of Mechanical Subassemblies for Harsh Environment Electronics," *Proc. of the International Welding Conference on Efficient Welding and Industrial Applications (ICEWIA)*, LUT, Finland, Aug. 25–27, 1999, pp. 123–130.
- [13] Suoranta, R., and H. Eskelinen, "Interaction Between Virtual Engineering and Hypermedia Applications in Welded Steel Construction Design," *Computer Technology in Welding and Manufacturing*, TWI Ltd., Copenhagen, Denmark, Jun.6–7, 2000.

-
- [14] Eskelinen, H., P. Eskelinen, and K. Tiihonen, "Novel DFMA-Tools for Passive MW- and RF-Components in Cost-Effective Mass Production," *Proc. of 30th EuMW-Conference*, Paris, France, Oct. 3–5, 2000, pp. 88–91.
- [15] Suoranta, R., and H. Eskelinen, "Interaction Between Virtual Engineering and Hypermedia Applications in Selecting Heat Treatments for Welded Microwave Components," *Proc. of the IIW Asian Pasific International Congress Incorporating the WTIA & NZIW Annual Conferences*, Melbourne, Australia, Oct. 29–Nov. 2, 2000.
- [16] *Mini-Circuits RF Designer's Handbook*, Brooklyn, NY: Mini-Circuits, Inc, 1997.
- [17] Eskelinen, H., "Laser Processing—An Optimal Tool for Encapsulating Electronics," *Proc. of the 7th Nordic Conference in Laser Processing of Materials (NOLAMP)*, LUT, Finland, Aug. 23–25, 1999, pp. 491–496.

8

Other Joining Technologies

In addition to welded and soldered joints, many microwave applications need screw joints to enable the opening of the device at a later time. On the other hand, for those applications where various types of materials are joined together (e.g., metals with plastics) or no heat input is allowed, the use of adhesives is practically the only reasonable joining technology. If exact accuracy in the positioning between the joined components is required along with good sealing and hermetic properties, special fitting joints are utilized.

8.1 Assembly Rules for Screw Joints to Obtain Reliability and Required Microwave Performance

There are numerous instructions for designing screw joints in mechanical engineering. In this chapter, we have gathered the most important hints for improving their reliability. Because the application area of screw joints in microwave mechanics is quite wide, it is reasonable to divide the joint types into two main groups. The first group includes relatively small-sized and lightly loaded joints (e.g., those used for joining covers of enclosures, assembling circuit boards into housings, or joining small devices with the body of the construction). These joints are also used in microwave devices that are assembled in vehicles. The second group includes relatively heavily loaded screw joints (e.g., those used for antenna assemblies in towers or in guyed masts). According to this division, there are two failure types to avoid: There

is a risk in the first group that the joint could loosen or even open little by little due to vibration. In the second group, depending on the conditions, screws are exposed to a variety of mechanical loading. The screw joints placed in mast mounted antennas have to withstand large static and dynamic loads due to wind and ice, and in some circumstances fatigue failure is also possible. Even though the division into groups is reasonable in microwave mechanics, the most common failure of screw joints is still corrosion (80% of failures take place due to corrosion).

To prevent the unwanted loosening of a screw joint, some appropriate adhesives can be used between the threads. Flexible or locking types of adjusting washers can also be used. In general, the screw should be more flexible than its base (it is the components that are joined together). The selection of an appropriate washer is important for many reasons. In addition to preventing unwanted loosening of the screws, it also protects the surface of the joined components, adjusts the position and direction of the screw (which prevents bending stresses), and helps to equalize surface pressure between the nut and the base. Note that different material pairs may lead to passive intermodulation products. In practice, the mechanical failure of a screw joint can take place in two ways: either the maximum tensile strength of the screw is exceeded, or the thread is sheared out from the nut (or screw). It is also possible (if the strength of the screw is over-dimensioned or the screw is placed too near the edge of the joint) that the parts to be joined could break (e.g., thin sheet metal parts). To prevent fatigue failure, two means are generally used. First, the peak stress should be reduced. Second, the shape factors of possible cracks from which the failure can start should be improved. In preventing fatigue failures in screw joints, the tightening moment of the screws plays a key role. It should be selected and controlled so that the stresses in the screw are divided onto several threads. In most cases, the first thread is overloaded if a wrong moment is used. The surface roughness of the root of the threads should also be improved. The root can actually act like a crack from which the fatigue failure might start. Longer nuts can be used to divide the stresses on the longer surface along the threads. Nuts with a smaller coefficient of elasticity than the screw can also be used. In general, the stresses will be equal between the threads. Finally, the thread profile should be especially selected for fatigue loading (the typical M-profile is not always the best one). In many cases, dense threads are not recommended either.

In addition to the instructions mentioned above, there are some useful hints for designing screw joints for microwave applications. In Europe, one should use only millimeter-dimensioned screws whenever it is possible

because inch-based sizes are difficult for tooling. If a screw mechanism is used for any control or adjusting action in a passive microwave component, specialized high-accuracy thread tolerances might be needed. Special thread profiles are even possible to manufacture but could be expensive. A typical example is a simple tuning screw (or rod) in a waveguide resonator in which both an accurate adjustment function and a reliable galvanic contact are desired. Sometimes the solution can be just a commercial-grade fine-threaded screw. In microwave mechanics, light metal alloys and all plastic constructions are quite common. For these materials, there are several specialized screw and nut types. Their standardization is not ready yet, however. There are screws, for example, which can be used directly as a screw-tap when assembling plastic components. When assembling multiscrew joints, it is important to take care to employ an equal and alternate tightening of each screw to ensure an equal stress division between the screws.

8.2 Glued Joints

If glued joints are intended to be used in mechanical microwave components, two fundamental questions need to be solved: What are the constructional requirements for the joint, and what is the appropriate adhesive type for the application. The selection of the most appropriate adhesive [1, 2] is based on several criteria: required electrical conductivity, required thermal conductivity, coating and sealing performances, method of applying the adhesive, type of joining process, UV-protection, flexibility of the joint, material pair to be joined, temperature range, and required strength properties. Let us have a closer look at the selection process of basic adhesive types, which can be used for passive microwave components [2, 3].

8.2.1 Acrylic-Based Adhesives

In principle, these adhesives are made for locking, retaining, and sealing. A number of microwave components may require such properties as well, mainly for the thread locking of screw joints. Some acrylic-based adhesives (usually in the form of fluid) are designed to eliminate the loosening of threaded fasteners, for example, due to vibration. In addition, these adhesives can be used to improve the sealing properties of screw joints and to protect the threads from corrosion. Another important application within the microwave field is their use in joining metallic extruded products, or profiles, with each other. These adhesives could easily be applied in many sheet metal microwave components. The strength and viscosity of the adhesive can be

used as a design parameter. We can expect that a good adhesive shows a cutting resistance above 15 MPa and a breakaway torque near 20 Nm. In most cases the temperature range is not critical because most manufacturers guarantee the joining properties at working temperatures between -55° and $+150^{\circ}\text{C}$. The viscosity plays a key role to ensure that, for example, in long holes, the last thread will be filled with the adhesive. There are tens of acrylic based adhesives within the viscosity range of 10 to 70,000 pcs.

8.2.2 Cyanoacrylate-Based Adhesives

These adhesives are developed for joining engineering plastics and include several tens of variants for specific material pairs. The following plastics, for example, can be handled: PET, PA, PE, ABS, EPDM, PP, and even PVC. Cyanoacrylate based adhesives are also suitable for joining rubbers and some metals and have good resistance against temperature. There are dramatic differences between the properties of joining PVC plastics. Additionally, the maximum tearing strength can be chosen inside a wide range from 3 to 40 MPa. The maximum working temperature is typically only 80°C (of course there are some special adhesives for higher temperatures as well). Manufacturers usually print good comparison tables for their commercially named and coded products. An example of the typical microwave application is the joining of plastic insulator elements to metallic device bodies.

8.2.3 UV-Cured Adhesives

Many microwave devices need means to join several types of plastics like ABS, PC, PEN, PET, PVC, MYLAR, and laminates. Most UV-cured adhesives are suitable for joining glass and crystal as well. There are some types of UV-cured adhesives that have relatively high moisture and solvent resistance. This determines their selection along with the plastics having the same kind of properties (moisture resistance plays an especially key role). For these reasons, UV-cured adhesives are also used in mechanical microwave components.

8.2.4 Adhesives with Good Electrical Conductivity

This is probably the most important group of adhesives for mechanical microwave devices. The application area is quite wide. These chemicals can be used for the simple joining of some wires or strips, instead of using soldering, or even when assembling large metallic antenna bodies or other similar devices. There are various types of adhesives in this group. They can be either single or two-component adhesives based on silicon or epoxy. Silver is

alloyed for low resistivity. Depending on the application, there are specific adhesives that have high ionic purity and good resistance against heat. If the silver alloyed adhesives are too expensive and it is possible to work with a slightly higher resistivity, graphite and carbon-based products can also be used. Silicone compounds are available for more critical heat transfer applications. The working temperatures for these adhesives, however, are normally between the range of -50° and $+170^{\circ}\text{C}$, which in most cases is acceptable. The shear strength is not much higher than 12 MPa, but this value depends dramatically on the curing conditions. For a typical silver paste adhesive, the volume resistivity (if the joint is cured according to instructions at 60°C) is $0.0005\ \Omega\text{-cm}$. The value of resistivity is about 100 times higher if epoxy based silver solder is used instead of adhesive. Water absorption depends of course on the adhesive type, but is about 0.5% for silver based pastes. The thermal conductivity of a typical silver paste adhesive is about $2.5\ \text{W/mK}$. Economical graphite or carbon-loaded adhesives are available for general purpose conductive bonding, including dual electrically and thermally conductive joints.

The joint geometry should be selected and designed for adhesive joining. Figure 8.1 shows an example of a glued joint inside a low loss filter. The center conductor, which is an aluminum strip, is glued to a SMA connector's center pin, which is actually a wire. The contact area is almost a line. From Figure 8.1, it is easy to see that the "seam" is more like a "clod" on the strip than a proper joint. It is also certain that there is some porosity inside the joint. The strength is surely unacceptable, and possibly the electrical properties are as well.

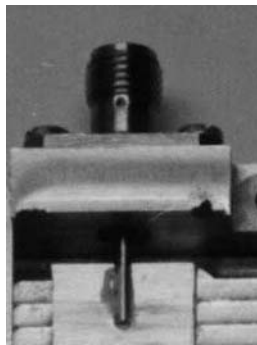

Figure 8.1 An example of a glued joint inside a low loss filter. The difficulty of joining the center conductor to the SMA connector's center pin can be seen. The "seam" includes some porosity and its strength and electrical properties are poor.

Figure 8.2 includes another example of glued joints. An antenna body is constructed using electrical conductive adhesive. The intention here was to join the groundplane, which is a sheet metal part, to four U-profiles in order to manufacture the outer conductors for the feeding striplines. The joints between the groundplane and the profiles should therefore be electrically perfect. In this case, the problem was the difference in the rigidities of the plane and the profiles. Because the plane was not straight enough, it acted more like a “spring” against the profiles, which—opposed to this—were too rigid to adapt themselves to the shape of the plane. The straightness error of the groundplane was due to the welding of the radiating elements on it. An attempt to use pressure during the curing stage of the adhesive proved to be useless—immediately after taking the pressure away almost all of the seams opened. This example shows how obvious it is that the whole construction should be designed for the use of adhesives—not just the detail on which the adhesive will be sprayed.

8.2.5 Adhesives for High-Strength Applications

There are three types of adhesives for those cases where special strength properties are required from the glued joint. Either polyurethane adhesives, multipurpose epoxy adhesives, or silicon based adhesives can be used. In MW

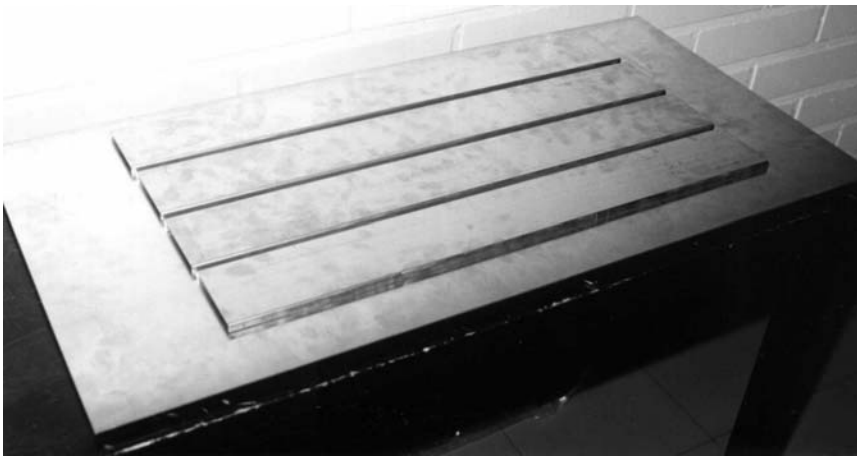

Figure 8.2 The differences between the rigidity properties of the antenna’s groundplane and the U-profiles for the striplines made it difficult to achieve a glued construction. Although the parts could be forced together with pressure during the curing stage, the joints opened immediately after relieving the pressure.

mechanics, these kinds of adhesives can be used for joining metallic materials.

8.2.6 High-Temperature Ceramic Adhesives

The joining or insulating tasks of high-temperature electrical resistor elements require special adhesives. These kinds of adhesives are used for the sealing of high-voltage capacitors, for example, and for the coating and insulating of high-voltage coils used in radio transmitters, radars, and in aerospace and defense equipment.

Properties of some common adhesives are presented in detail in [4], and further information about designing glued joints is given, for example, in [5].

8.3 Applications of Fits

In Chapter 9, we present two milled microwave filters and two ring-hybrid constructions, which are quite typical examples of passive microwave constructions. In these applications, exact fits have been used to ensure the radio frequency shielding properties of the cavity, to ensure the positioning of the SMA connectors, or to ensure the positioning of the “third component” (here, the center conductor). The detailed technical drawings, with appropriate tolerance requirements and symbols, are presented on the attached CD-ROM.

The following instructions should be followed when designing fittings for MW applications. If a fitting should be designed between a hole and a pin, or between a cavity and its cover, always use fundamental deviations of grade H, in which the lower deviation is always zero. It is easier for manufacturing and easier for selecting the appropriate fit. Slight interference fits are possible in cases where, for example, a flexible plastic insulator element for an SMA connector is placed inside a metallic hole. A pressing tool is needed for assembly, however, and one must avoid pushing the insulator out of the connector body. If the sealing properties of enclosures are designed to be based on the fit between the cover and the bottom, there should always be a flange to ensure the positioning. If the joint is ensured with screws, any transition fit is acceptable. The use of interference fits can cause difficulties in assembly. It is also possible that during the assembly the cover could bend or twist. Each time a fit is opened and closed, the dimensions of the joining shapes and surfaces will change slightly. A slight transition fit can therefore “change” into a clearance fit if it is opened several times. If a fit is used to enable the

moves, either linear or rotating, between the components, clearance fits are typically used. The accuracy of these mechanisms usually changes dramatically due to wear. Thus, the material selection of the surface is important. The IT-grade of the fit should be selected to match the other accuracy requirements of the product (dimensional and surface properties). The selected fits should always be based on international standards if possible. Cross-sectional tolerances are generally more critical because they define the matching characteristics of most microwave transmission lines. As an example, the radio frequency performance of a body-mounted SMA connector will be degraded if the hole diameter is too large by 0.1 mm. This is due to a severe impedance mismatch. Alternatively, if the center conductor of the same connector is misaligned by 0.2 mm or more with reference to its mating microstrip line inside an enclosure, a similar electrical defect may be caused.

More and detailed instructions of the use of fits are presented, for example, in standard ISO-286.

References

- [1] Kalpakjian, S., and S. Schmid, *Manufacturing Engineering and Technology*, New Jersey: Prentice-Hall Inc., 2000.
- [2] Eurobond Adhesive Limited, "Meeting the Needs of Productivity and Product Integrity," <http://www.eurobond-adhesive.co.uk>, Feb. 10, 2002.
- [3] Panacol-Elosol GmbH, "Innovative Special Adhesive," http://www.panacol.de/_gb/_prod, Feb. 12, 2002.
- [4] Farag, M., *Materials Selection for Engineering Design*, London, England: Prentice-Hall, 1997.
- [5] Wright, P. K., *21st Century Manufacturing*, New Jersey: Prentice-Hall Inc., 2001.

9

Machined Components

The professional literature of mechanical engineering has always shown a contradiction between the terms “sheet metal cutting” (refers to several shearing processes of sheet metal parts) and “cutting in general” (refers to such common machining processes as turning or milling). To avoid this confusion, it might be better to just accept that cutting is connected to sheet metal work, and machining deals with those material removal processes in which material is “cut” apart in the form of chips.

The most important machining processes for mechanical microwave components are of course turning, milling, drilling, and several finishing processes. In many microwave applications, however, high-speed machining or ultraprecision machining is necessary to meet the performance requirements of the product. In many cases, the specified geometry of the workpiece gives limited possibilities of using standardized tools for manufacturing. For MW engineering, only the use of modern computer based numerical control (CNC) machines of high quality is acceptable. Therefore, most of the quality errors in the production of mechanical microwave parts are caused by machining (e.g., milling) forces. This sets special requirements for material selection and fastening systems.

9.1 General Rules for Machining Technologies

Two main tasks must be handled during a practical production design:

1. The selection of appropriate machining processes with respect to the required geometry;
2. The definition of machining parameters and tools according to the workpiece material.

A thorough understanding of the basics of chip formation mechanics and the effects of each parameter on the process is vital for best quality. The most important characteristics (basically for any machining process) are [1]:

- Feed;
- Depth of cut;
- Cutting speed;
- Tool geometry;
- Tool angles;
 - Side-rake angle;
 - Back-rake angle;
 - Side-cutting edge angle;
 - End-cutting edge angle;
 - Side-relief angle;
 - End-relief angle;
- Material and/or coating type of the tool;
- Nose radius.

A machining process is typically controlled by these characteristics [1, 2]:

- Machining forces and required machining energy;
- The size and geometry of chips;
- Tool wear (real time control);
- Tool temperature (cooling, need of cutting fluid);
- Tool deflections;
- Relationship between the size of the volume to be machined and the number of flutes, which are engaged in chip removal.

In general, the result of a cutting process is estimated with the following characteristics:

- Volume of the removed material/time unit;
- Quality of the surface (usually R_a);
- Dimensional accuracy (usually classified with IT-grades);
- Tool wear rate (post-control).

The tolerance system for limits and fits in the ISO 286-1 standard provides 20 different tolerance grades (usually called IT-grades) designated as IT01, IT0, IT1...IT18 in the size range from 0 to 500 mm and further 18 grades in the size range from 500 mm up to 3,150 mm (designated as IT1 to IT18). In theory the values for standard tolerances are defined as a function of the standard tolerance factor “i.” This function is empirically derived being based on the premise that, for the same manufacturing process, the relationship between the magnitude of the manufacturing errors and the basic size approximates a parabolic function. The values of the standard tolerances are then calculated by using this factor “i” and tabulated for practical use (for further information see ISO 286-1/Annex A/pp. 28–31). The milled microwave components, which are presented in this chapter, illustrate the importance of utilizing appropriate tolerance grades for each application.

Let us try to combine a simplified “optimizing procedure” from the different characteristics listed above. First of all the purpose is to maximize the surface and dimensional quality of the product. To reach maximal productivity we would also like to reach the largest possible amount of removed material per time unit. To minimize the tooling costs we desire that tool wear is in its minimum.

In practice, we try to find the most effective cutting parameters according to the material properties of the workpiece. This is assisted by hundreds of semiempirical tables, but the user must observe the tight connection to the tool’s material (or coating). With correct parameters, chip formation is fluent, tools will not exceed their temperature limits, and machining forces will not cause problems (e.g., twisting or bending of the workpiece).

The simple tabulated scheme is ruined by the special material alloys or complicated cutting geometries found in microwave mechanics. Every alloying material or the selected heat treatment can essentially change the machinability properties. If a specific material is classified as being “difficult to machine,” it means that one of the following problems might turn up:

- Chips stick on the tool and destroy it or the surface of the workpiece.
- The material is too fragile and it crumbles.

- The material is too flexible to be properly fastened.
- The material is too hard causing extensive tool wear.

One example of difficult microwave components is the center pin of coaxial connectors. In some applications we have needed a half-circle cross section of the pin instead the original circle. The commercial CuBe2-alloy proved to be extremely hard (a good feature for successive connecting cycles!) and therefore difficult to mill.

For the designer, we have collected some useful data sheets including machinability information into attached CD-ROM.

Chips or powder remaining inside the machined microwave geometry (e.g., holes, cavities) can cause a dramatic malfunctioning of the electrical device. It is therefore important that the manufacturing instructions include the remark of required cleaning. Usually compressed air or isopropanole washing combined with the complete drying of the component is used. Unfortunately most of the construction materials are nonferrous which disables the possibility to use magnetic processes for chip removal.

The basic design rules to make the manufacturing process of machined components easier are as follows:

- Try to minimize the volume of material to be removed.
- Try to design the workpiece and the order of the various manufacturing stages so that repeated fastening cycles are avoided.
- Reserve some space on the workpiece for fastening.
- If the workpiece is long, thin or flexible, allow some supporting areas on the workpiece to avoid twisting or bending due to machining forces.
- Try to select geometries suitable for common standardized tools.
- When designing so called closed geometries leave enough space for using tools for different machining processes (typically forgotten, e.g., when setting requirements for finishing the surface).
- Aim at symmetrical geometries and constant fillets and chamfers.
- If a conical geometry is to be manufactured by turning it is always easier to finish the process on a geometry of a turned cylinder than on a perpendicular plane (either an inner or outer cone is to be manufactured).
- It is always easier to start drilling on a perpendicular surface.

- If there are several inner diameters inside a turned hole there should be a possibility to use chamfered boundaries in between (rather than fillets or planes).
- The area or volume of the material to be removed by milling should be dimensioned in the drawings as well as the position of this geometry.
- The final dimensions of the workpiece should be presented for turning.
- The corner radius of milled inner geometries should be selected according to standardized tools and no sharp-edged geometries should appear.
- Milled outer chamfers are easier to manufacture than rounded geometries.
- The end of drilled embeddings should be allowed to remain in the form of the bore bit (typically a conical geometry).
- Use equal distances between similar geometries (e.g., distance between holes that will have threads).
- Avoid so called double-tolerancing.

The functional requirements of many mechanical microwave components seriously violate the previously mentioned requirements. Some of the special machining aspects are illustrated by the following applications.

9.2 Milled Low Loss Filters

A sixth-order 10% Tschebyscheff bandpass filter with a 0.1-dB attenuation ripple was used to test the effects of different milling technologies on the obtainable RF performance. The expected documented results of similar designs in literature [3] suggest a residual attenuation around 0.4 to 0.5 dB, 3/60 dB bandwidth ratio of 1 : 3 and an input VSWR between 1.1 and 1.3. The efforts here were particularly focused on the resonator surface quality, the definition of the resonator length (which mostly depends on the geometrical shape of the short circuiting blocks), and on the minimization of radiation losses. Four samples were constructed; two as references and two with enhanced manufacturing specifications.

On the attached CD-ROM we present the composed 3-D CAD model of the center conductor of this filter with screw mounted SMA connectors.

The same Genius Mechanical Desktop 3-D model (or converted DXF data) is used for performance simulations, assembly checking and tool controlling in milling and drilling to ensure the effective use of the computer-aided CE environment [4].

The key findings include the crucial importance of the possible difference in the dimensioned and milled lengths of the individual resonators. This is illustrated in Figure 9.1 as a Smith chart, which shows the complex impedance matching of the two filter ports as a function of frequency. If the selected milling method produces a curved resonator root (known also as resonator base), the accurate length is no more predictable by computation and part of the incident wave will be reflected. In order to get a better impression of the mean performance, the recordings were fitted inside ellipses having an arbitrary focal axis intersection. The milled filter construction is presented in Figure 9.2 and the critical detail in Figure 9.3.

The results showed that resonators with a rounded root produce a worse matching which is observed as a greater radial distance from the chart center. During the manufacturing process of this specified filter construction the most critical aspect is to control the bending and twisting of each strip. Relative large amounts of the bulk are actually milled away and forces may be high. These may lead to deformations, which disturb the performance either

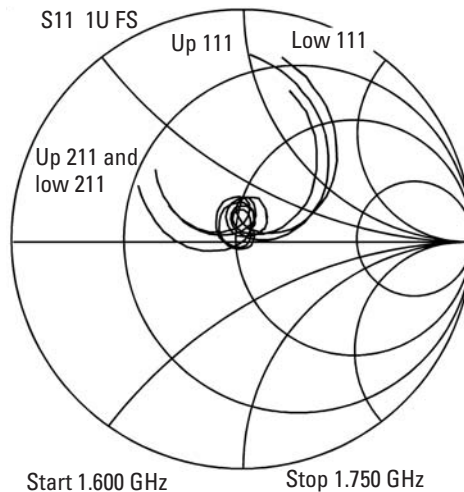

Figure 9.1 The Smith chart presentation of S_{11} shows already that the two filters with ultimately sharp resonator roots (known also as resonator base) give a good impedance match over the entire passband. It is obvious that the upper unit of the reference sample had an imperfect connector mounting as well [4, 5].

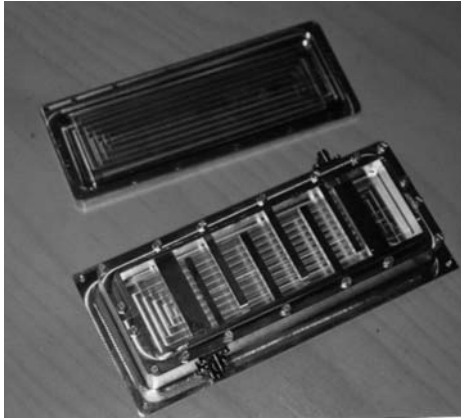

Figure 9.2 The tested filter is a fully machined construction. The track of the milling tool is visible on the bottom, but the surface roughness is better than $0.8 \mu\text{m}$. The sharpness of the resonator root has the key role. Due to milling technology it is impossible to get absolutely sharp edges of the body itself [4, 5].

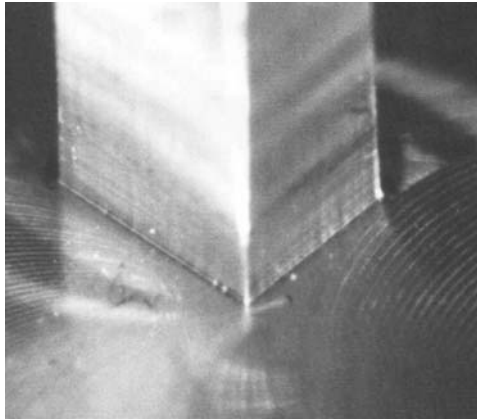

Figure 9.3 A photo of the resonator root (side length is 5 mm). If the root is rounded it means that the calculated and simulated resonator lengths will differ and the perpendicularity will be disturbed near the root. Some unwanted modes could be generated [4, 5].

because the depth of the air gap will be changed or because the construction is not dense after assembly. The geometry of the center conductor is also awkward for any fixturing system. A partial solution can be found from proper materials.

The performance of a mechanical microwave product is a compromise due to different aspects of material selection, manufacturing accuracy, and of course the designed geometry. The filter that we are discussing here, for example, could be of sheet metal stripline type or this milled construction. In our particular case, the main body where four such filters are finally assembled is a milled antenna construction—that gave a good reason to find more innovative solutions for cost-effective machining. One promising alternative is the utilization of a specific aluminum alloy called ALUMEC. Actually this high strength alloy is originally developed for the requirements of aircraft industry but due to its excellent machinability properties it can be used in applications where high tolerance requirements should be met. In our case the strength is utilized to ensure the exact post-milling perpendicularity and straightness of the resonator. See the detailed material data in Section 3.4.7.

Fully detailed manufacturing documents (AutoCAD drawings) of this filter design are presented in the attached CD-ROM files.

9.3 Ring Hybrids and Other Milled Power Dividers

The mechanical construction of a conventional 1.2- to 1.8-GHz four-port ring hybrid body is presented in Figure 9.4. Four SMA-type connectors are needed. The requirements for a water jet cut center conductor are presented in Chapter 10 and fully detailed manufacturing documents are available on the attached CD-ROM.

The following dimensions of the milled body are essential for top performance:

- Positioning accuracy of the SMA-connectors;
- Perpendicularity of the side walls of the body against the bottom and cover and against the middle cylinder as well;
- Position and diameters of the lifted cylinder on the bottom;
- Sealing properties of the enclosure (fit between the cover and bottom);
- Maximum allowed distance between the mounting screws (depending on the operating frequency);
- Surface roughness of the inner surfaces;
- Straightness of the body.

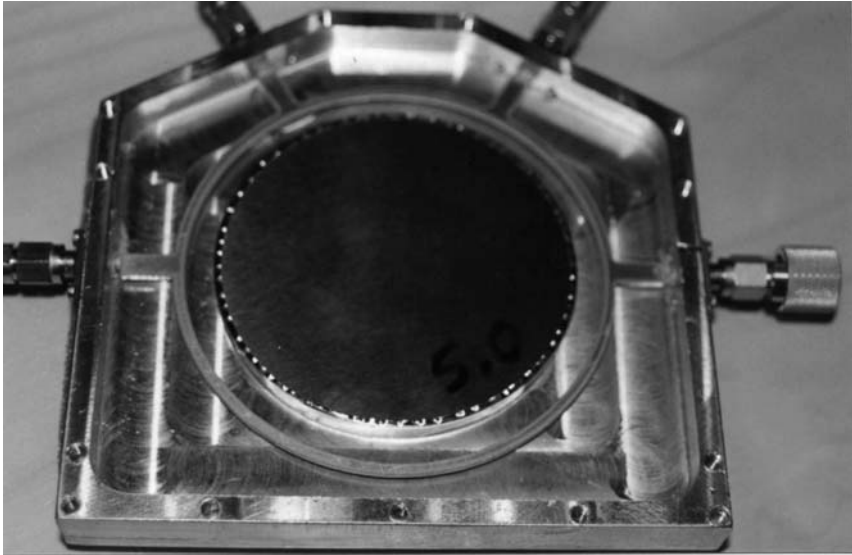

Figure 9.4 The mechanical construction of a conventional 1.2- to 1.8-GHz four-port ring hybrid body (prototype).

This milled construction has some problems in the view of easy manufacturing:

- Two of the strictly dimensioned mounting holes for the SMA connectors must be drilled on the chamfered sides of the body in addition to their threaded fastening holes.
- The distance between the mounting holes of the cover is not constant. Because of the connector mounting screws there is the area on the sidewall where other holes cannot be drilled and the chamfered geometry requires extra counting.
- To ensure the sealing properties of the body there should be a step on the cover, which fits tightly inside the body walls. However, because the inside corners of the body need to be rounded due to tooling there is a problem to manufacture similar rounded corners outside the step.
- It is hard to avoid double-tolerancing: The bottom and the cover should have an accurate distance from each other to build up the air gap but at the same time the middle cylinder and the cover should be

in contact. There should be a tight fit between the cover and the body's sidewalls and at the same time the mounting holes should have an accurate position both in the bottom and cover. Center strip should be at the right distance from the middle cylinder and at the same time it should reach the center pins of the SMA connectors.

A stylish mounting of the conventional SMA-type connector on the sidewall was complicated. Because the enclosure is so thin, it was not possible to rotate the connector so that at least one of the assembly holes could have been fully inside the bottom material. Also the thickness of the sidewall is so thin that the threads extend through it. As presented in Figure 9.5, this caused some unwanted errors and the mounting holes protrude the sidewall. Obviously this can disturb the performance of the device but the problem was solved by special-size mounting screws. However, this error shows clearly

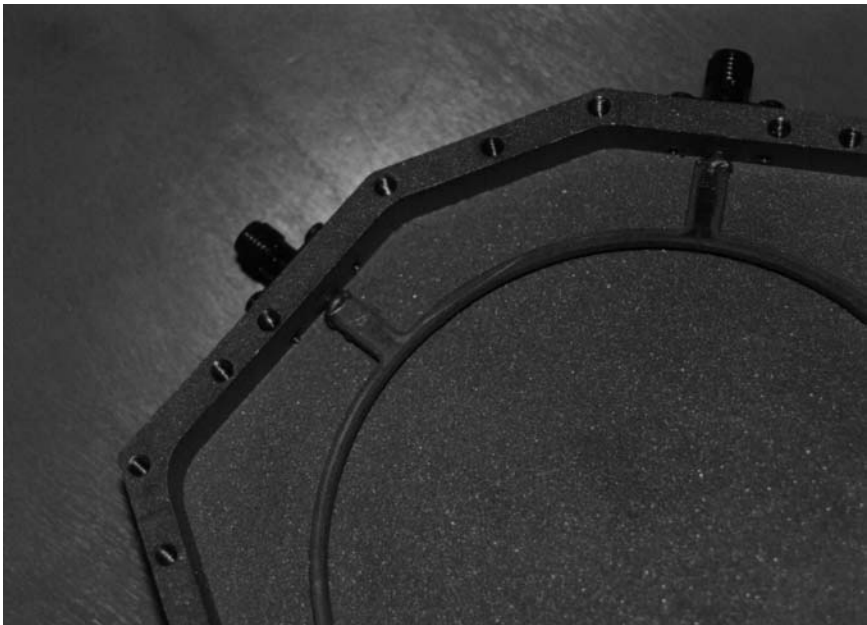

Figure 9.5 The connector screws prevent a constant distance between the mounting holes of the cover. An SMA connector seems to be too large even for this relatively clumsy milled construction and therefore the mounting holes break both the side wall and the bottom of the enclosure. The problem was solved in the final construction by using special sized screws.

that in many microwave applications some traditionally used standardized components, like connectors, might set the strictest requirements for the geometry. Leading connector or cable manufacturers should carefully listen to the voice of designers. They ought to be prepared to develop their products in line with advanced mechanical manufacturing technology following the needs of the customers.

It is reasonable to keep the number of microwave connectors low due to better reliability and smaller attenuation. The price of the SMA connectors could be the highest part of the total costs in volume production. In Figure 9.6 we present a milled construction where we have combined three ring hybrids together. By using this integrated construction three main advantages can be achieved:

1. The number of required SMA connectors will decrease by four, the number of cables by two.
2. The sources for disturbance and loss can be reduced.
3. The dimensions of the construction are essentially smaller compared to the one with three separate ring hybrids.

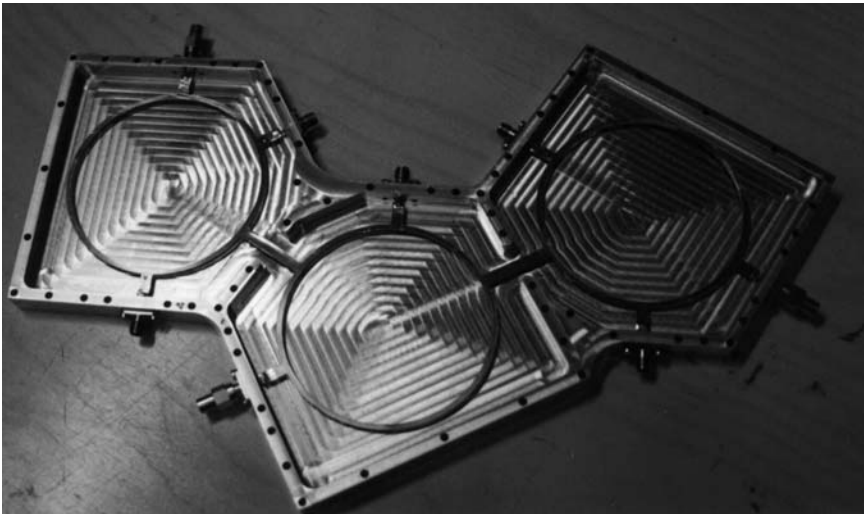

Figure 9.6 An integrated ring hybrid. The straightness of the body should be controlled carefully during milling. Also the inlets between each cell need some extra milling stages. However the number of connectors can be reduced, the performance improved and the dimensions brought smaller.

From the manufacturability point of view there are a few problems to be solved: Because the inner surface becomes much wider it is possible that some bending or twisting can take place during the milling stages of the bottom. This problem can be handled by using a separate milling stage afterwards during which the bottom will be straightened. The second problem is the milled details near the inlets of the three cells of the construction. Extra milling stages are hard to avoid. The full details of the construction are presented on the CD. Of course the 3-D modeling (or direct CAM programming) of this product is a bit more complicated. However, because the three cells are symmetrical most of the operations can be made by using automated CAD commands or wizards.

These case examples show clearly that many aluminum alloys have relatively good machinability. However annealed alloys are a bit difficult due to their softness. Hardening and cold working processes essentially improve machinability. Another way to improve machinability, in addition to appropriate heat treatment, is to select an alloy, which contains either lead (Pb) or bismuth (Bi). These two components ensure that the chips are short and are cut easily. Those aluminum alloys, which contain relatively large amounts of copper (Cu), have good machinability. If silicon alloyed aluminums are used, usually high speed machining is necessary together with specialized tooling. This is because these alloys might include some very hard silicon inclusions, which tend to wear the tool extremely heavy. The authors have used successfully not only ALUMEC but also AlSi1MgPb alloy. If we compare these applications with steel constructions we can summarize that the cutting forces are about one fourth but because cutting speed is much higher the required cutting power is somewhat higher as well.

Some new ideas to improve the RF performance, particularly isolation, of S-band ring hybrids through selected mechanical tricks are shown next. The most important observation (e.g., see [6]) is that the best available isolation value with the classical design can hardly exceed 40 dB which is typical for commercial OEM units as well, (e.g., see [7]), although the measured attenuation between adjacent ports was less than 3.2 dB, or only 0.2 dB above theoretical. A modified arrangement is illustrated in Figure 9.7, where the complete hybrid, redesigned for 3.1 GHz, is seen opened to reveal its printed circuit board center conductor. The coaxial stripline launchers are kept in place by mechanical pressure, thus reducing the discontinuity at the transition. The case milling uncertainty required for a successful and repeatable connection was 0.01 mm. The suggested principle looks promising, as is shown in Figure 9.8. We are able to add about 20 to 30 dB of isolation, thus ending with 70 dB, depending on the overall accuracy of the

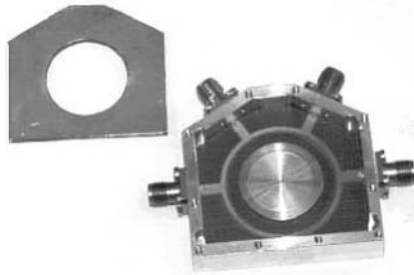

Figure 9.7 Our practical construction is assembled from a sturdy milled aluminum housing and two Teflon based circuit boards, the upper one of which is removed to show the ring geometry inside which the blocking cylinder is mounted. An extension, which adjusts the outer radius of the cylinder for some trials, is just visible [8].

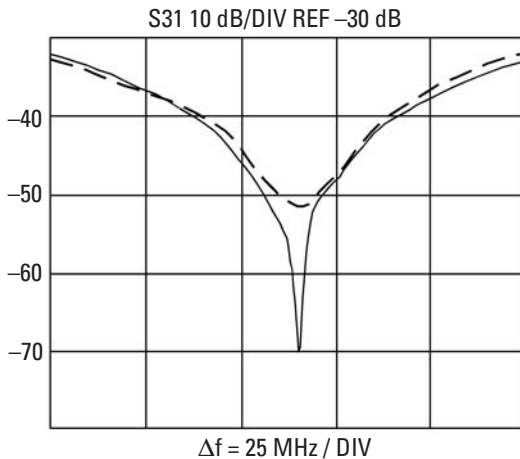

Figure 9.8 The best obtainable isolation with a conventional, carefully assembled hybrid (dashed line) and the improvement, which came through the enhanced connector mounting scheme at 3.1 GHz [8].

mechanical lay-out, but at 3.1 GHz the losses in the circuit board start to come up.

When striving for extreme performance we made an experiment—inspired by the classical but frequently cited work of [9]—with a tuning screw positioned just above the coaxial launcher of port four as demonstrated in Figure 9.9. The 2-mm screw goes through the upper circuit board and approaches the ring geometry from above thereby adding some

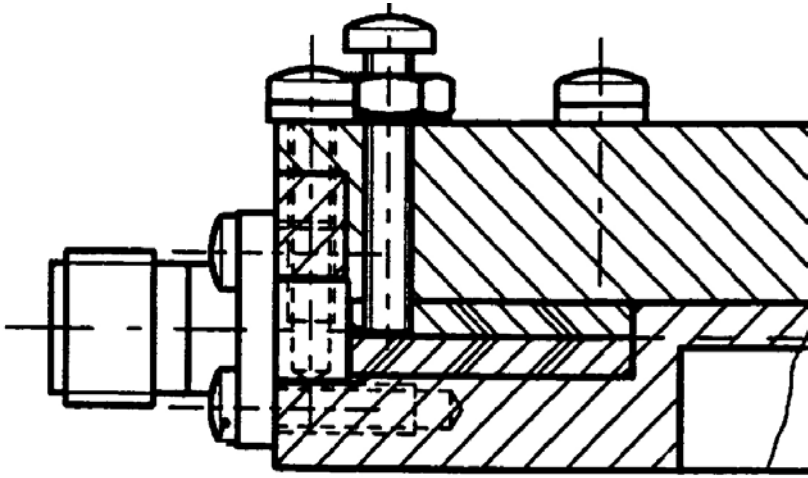

Figure 9.9 A tuning screw was mounted next to the coaxial input for the fourth hybrid arm to further improve isolation by adjusting the port impedance [8].

stray capacitance in the order of some tens of femtofarads. As is seen from the drawing, the electrical connection is maintained across the entire length of the screw thus minimizing unwanted inductance. However, for very high power applications, a different screw mounting should be considered in order to avoid generating passive intermodulation products at the screw-to-chassis connection point.

It seems that the trial was successful. The plot in Figure 9.10 certifies the obtained isolation of 97 dB, actually a result that approached the limits of the vector network analyzer. Again here the wanted coupling between ports 1–2 and 2–3 stays stable. The measured values were demonstrated to be typically 3.15 dB (3.08 dB best case), and had a data spread, as is seen in Figure 9.10, of about 0.1 dB over the entire frequency band. Currently, it seems possible to apply similar concepts for other geometries, like those presented in [9, 10].

9.4 General Enclosures for Encapsulating Electronics

Many microwave prototypes, which are constructed mainly for evaluation or test purposes, can make use of milled enclosures instead of cast products (mainly due to the small production volume). Cheap sheet metal boxes, on the other hand, suffer from poor radio frequency tightness and inadequate

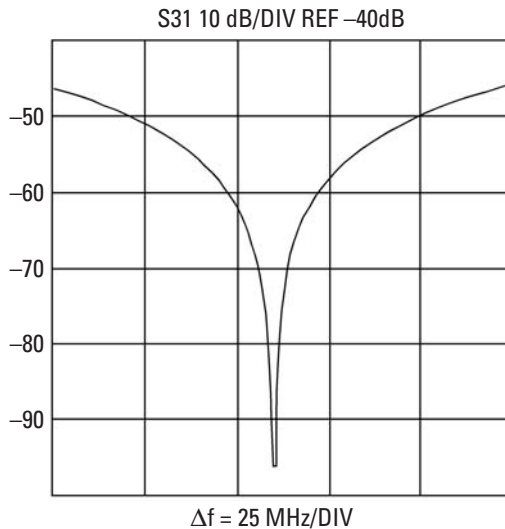

Figure 9.10 After optimizing the tuning screw depth, we get about 97 dB of isolation between hybrid ports 1 and 3 and simultaneously maintain the wanted coupling at 3.1 dB [8].

mechanical stiffness. The same general principles for designing machined components, which were listed in the beginning of this chapter, are valid here. Some special aspects, however, should be taken into account:

- Many circuit boards, which are made for evaluation purposes, seem to have variations of dimensions depending of their production series. This means that it is of no use to manufacture an exactly dimensioned enclosure according to the rough dimensions given in product catalogues.
- A milled housing always has rounded corners inside it. Therefore, either the corners of the circuit board should be rounded as well, or milled pockets near the corners of the housing should be specified.

Totally different problems will be encountered if a relatively large enclosure is to be milled. Figure 9.11 shows an opened housing for a patch antenna construction. The main dimensions of the housing are approximately length \times width \times height as 800 \times 450 \times 75. Full documentation and drawings of this body are presented on the CD-ROM.

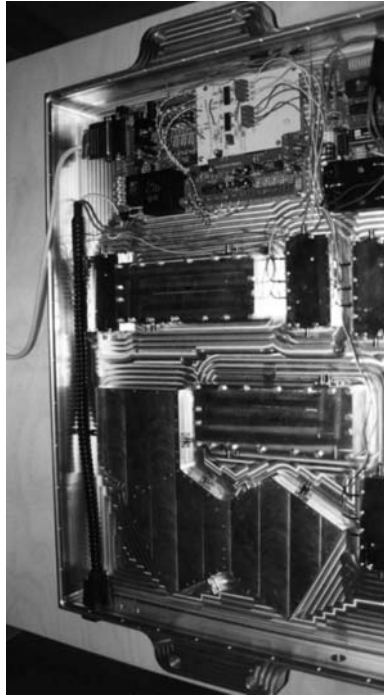

Figure 9.11 An example of a relative large milled enclosure, the use of which can be justified only by scientific reasons. In this case a rigid and dimensionally accurate enclosure for antenna tests was needed.

Such an expensive milled body can only be justified by the involved scientific purposes, which called for smallest possible mechanical instabilities of the construction. In this case, a measurement of the functional properties of a smart antenna was attempted. Additionally, the possibilities of using welded radiating elements were studied. Because it was known that the welding process itself would cause serious mechanical uncertainties, we wanted to use an extremely accurate body element to avoid other error sources.

We can make the following conclusions from this particular milled application:

- The total costs are at least 1,000 times higher compared to sheet metal enclosure.
- The manufacturing accuracy of a milled construction is 10 times better compared to sheet metal enclosure.

- The mechanical stiffness of a milled construction is 100 times better compared to sheet metal enclosure (no stiffening ribs on the back-side).
- The lane on which the milling tool has moved is easy to see from the surface, but the roughness is better than $R_a = 1.6 \mu\text{m}$ (see Figure 9.12).
- If the remaining wall thickness is small and the planar area is large, vibration problems during milling are obvious.

Basically there are two different types of vibration that can take place during this milling process:

1. Forced vibration caused by periodic applied forces present in machine (e.g., gear drives, motor) or imbalance of rotating tool components;

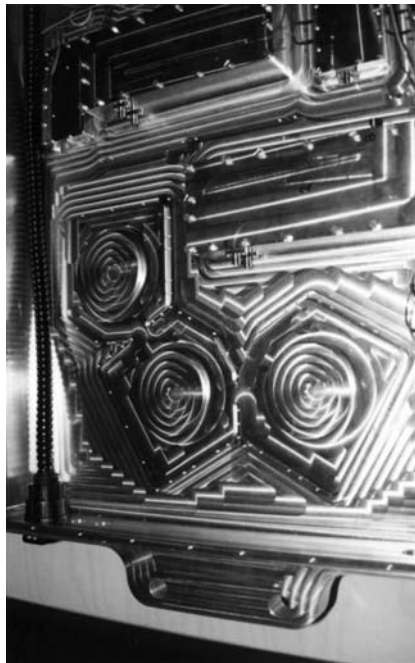

Figure 9.12 The lane on which the milling tool has moved is easy to see from the surface, but the surface roughness is even better than $R_a = 1.6 \mu\text{m}$.

2. Self-excited vibration caused by the chip removal process (phenomena between the tool and the chips).

The most important factor in controlling vibration during milling is damping:

- Internal damping results from the energy loss in materials during vibration (e.g., steel has less damping capacity than cast iron).
- External damping is accomplished with external dampers (different kinds of shock absorbers), which can be assembled into the machine tools.

As was seen during the manufacturing process of this antenna body, vibration can cause several problems:

- Poor surface;
- Decreased dimensional accuracy;
- Accelerated tool wear and damages;
- Noise.

To avoid vibration problems the following measures should be taken:

- The workpiece should be fastened rigidly.
- Tool overhang should be minimized (cutter should be assembled as close to the spindle base as possible).
- Cutter geometry should be chosen properly.
- Cutting parameters should be optimized.
- Stiffness of the machine tool should be increased.
- Damping capacity of the machine tool should be increased.

This quite unique example also shows how important it is for the designer to understand the relationship between the required manufacturing accuracy, possible surface roughness and final dimensions of the product. The larger the dimensions are, the more difficult it is to maintain absolutely correct dimensions and wanted surface roughness. For those microwave designers who are not well aware of the possibilities of various manufacturing

technologies, it is more than typical that tolerance and accuracy requirements are set too high. We recommend that, if possible, machined surface should be considered “good enough” for many applications if R_a is $1.6 \mu\text{m}$ and the respective accuracy equals IT-grade 7 (which is related to the dimensions).

Sometimes, so-called ultraprecision machining is needed for the higher microwave frequencies, say above 30 GHz. However, if the requirements of dimensional accuracy are on the order of $1 \mu\text{m}$, it is likely that diamond-based cutting tools are applied and some special arrangements during machining are necessary:

- Tool geometry, stiffness, and damping properties must be optimized.
- All the motions (linear or rotational, workpiece or tool) should be controlled.
- Thermal expansion of the tool should be balanced.
- Extra attention should be paid to selecting the appropriate cutting parameters.
- Real-time control of tool wear and condition is mandatory.

For all these examples made of aluminum it is typical that at least high speed machining (cutting speed $>1,800 \text{ m/min}$) is utilized. Also very high speed machining (up to $18,000 \text{ m/min}$) or even ultra high speed machining ($18,000 \text{ m/min}$) have proven to be economically reasonable. In general the following aspect must be taken into account when raising the cutting speed:

- More stiffness of machine tools is required.
- Tool holders and fastenings of the workpiece should also be stiffened.
- All rotational components should be well-balanced.
- The inertia of rotating components should be reduced.
- Materials for cutting tools should be reselected.

9.5 Connector Mounting Considerations

Milled mechanical microwave components tend to present the highest performance level of all and thus deserve a respective connector arrangement practice. The three important issues are:

1. Mechanical integrity (strength, stiffness of the connector mounting);
2. Accessibility (smallest possible efforts e.g., to mount a cable on the connector);
3. Low insertion loss and reflection coefficient.

The third requirement sets strict limitations on the geometry of the mounting layout. As the impedance of a coaxial line (and connector) is entirely defined by the ratio of the inner and outer conductor diameters and by the effective dielectric constant in between, there is not much room for a compromise [11]. Some selected commercially available coaxial connectors are illustrated in Figure 9.13. The relatively thick milled walls necessitate the use of so called extended dielectric-versions. It means that the milled component (filter, coupler, etc.) body has to provide the outer conductor. A typical connector for this kind of assembly is presented in Figure 9.14.

Although counter-nut versions of most commercial connectors are produced, they are not at all feasible when combined to an extended dielectric.



Figure 9.13 Some selected commercially available coaxial connectors (by Huber and Suhner AG [12]).



Figure 9.14 A typical SMA-type connector for thick wall assembly (by Huber and Suhner AG [12]).

This leaves only those flange-mount types with either two or four fastening holes to choose from. Some typical examples of these kinds of assemblies are presented on the attached CD-ROM. On the CD, there are also 3-D models of the most typically used connectors. These models can be used for practical design work. The technical drawings on the attached CD also include detailed drawings for appropriate assembly. Despite the fact that the selected SMA connector is one of the smallest, it may still be impractical. Besides, the clearance between the center conductor and the inevitable ground plane is theoretically only 2.05 mm. Such a small air gap may cause trouble if combined with a careless printed circuit board cutting, for example, or with sheet metal parts of arbitrary shape. On the other hand, the requirement for smallest possible inductances (to limit reflections) calls for “zero” tolerance!

Certain connector mating problems can be serious if, for example, a rigid connection between two adjacent assemblies is attempted through commercial adapters. This is partly based on the less strict outer dimensioning of connectors that is basically not needed because impedance will not change anyhow. Another issue is the quite large play allowed in the mounting flanges. If suitably combined, differences exceeding 0.5 mm can accumulate and the mating process may collapse.

9.6 Rotary Joints

One important microwave application in which high precision machining is necessary to ensure component performance is rotary joints (see examples in Figures 9.15 and 9.16). Typically a rotary joint forms the connection between the stationary and circularly movable parts within a microwave transmission line system (e.g., in radar or communication antenna equipment). Rotary joints are key elements, for example, when transferring microwave power to or from a continuously moving antenna. Actually their most common application is in different radar systems, where the antenna pattern has to cover the whole visible hemisphere. In addition, a rotary joint is typically assumed to be able to withstand high angular velocities (e.g., of shipborne radar antennas). Here, the scan rate is defined by the need to detect low flying targets early enough across the entire horizon. If only limited angular motion is desired, a flexible waveguide is often a better alternative. Of course, electronic beam steering is fast and intelligent when combined with an array but is not yet cost effective for the entire range of applications.

Basically, we can use both a coaxial and a true waveguide construction, depending, of course, on the frequency band and power level. The location



Figure 9.15 An example of a rotary joint. This specified Sivers RJ 6941 joint forms an integrated part of the scanner antenna in an airborne military radar. The model is designed to maintain its RF performance under very high levels of vibration and at high altitudes [13].



Figure 9.16 Another example of rotary joints. Here we have two axes of freedom to facilitate both azimuth and elevation scanning. This Sivers RJ 6947 model is designed for a missile application. A compact mechanical construction is one of the key features [13].

of a rotary joint happens to be most critical in a microwave system. It must handle the total transmitter power and, more notably, the peak power, where the risk of arcing is substantial. This implies that any impedance

discontinuities should be strictly avoided. On the other hand, the same rotary joint is one of the first attenuating elements in the receiving chain, and it thus partly defines the system noise figure. All losses in the joint are highly harmful. The metal surfaces must not generate any passive intermodulation products. In addition to all these requirements, a relatively complicated rotary joint geometry is mandatory in order to preserve the wanted propagating mode and polarization, where applicable. Multiple-path joints are the extreme in this application field.

A rotary joint has often several parallel microwave channels around the same concentric axis. In general there are seven types of rotary joints, which differ from each other in their functional or mechanical properties:

1. Basic waveguide rotary joints;
2. Swivel joints;
3. Coaxial rotary joints;
4. Hollow shaft rotary joints;
5. Contacting rotary joints;
6. Dual channel rotary joints;
7. Multichannel rotary joints.

9.6.1 Basic Waveguide Rotary Joints

The basic construction consists of two parallel waveguides that have coaxial transitions and a short coaxial line in between. The coaxial part is circularly symmetric, allowing free rotation without having disturbing effects on the performance. The position and polarization of the probes remain constant. In the rotating part, electrical continuity for RF is typically achieved by using $\lambda / 4$ chokes, which eliminate the need for metal contacts. High-quality bearings, however, are also needed to ensure a long operating life. In most cases, ball bearings are used. The waveguide ports can be placed in various positions depending of the application in which the joint is used:

- Both ports at a right angle to the rotational axis;
- One waveguide port at a right angle and one in line;
- Both waveguide ports in line.

Depending on the environmental loading and the requirements set for the weight, the material of the joint body can be selected quite freely.

The most often used alternative is dip-brazed aluminum. As shown in Section 3.4.7, this selection gives possibilities for a light-weight design and provides acceptable mechanical and microwave performance.

If needed, brass could also be used or various surface treatments applied to ensure that the construction would match with the connecting waveguides. From the mechanical point of view rubber seals are used to protect the inside surface of the waveguides and also the ball bearings from humidity and dust. If there is a risk of damages due to humidity, stainless steel bearings are used. Remarkable changes in the operating temperature during the use require a stabilizing water cooling system around the rotary joint body [13].

An illustrative cross section of a less typical rotary joint construction is presented in Figure 9.17. In this case the probe gradually transforms itself into a fin, which is used to feed the horizontal waveguide. Although the probe protrudes through the wall of the vertical transmission line (to the right), this is not really vital for the performance.

9.6.2 Swivel Joints

As the name hints at, this type of rotary joint is developed to twist only 60° degrees, which is often quite enough (e.g., for tracking antennas). The main advantages are:

- Remarkably smaller dimensions;
- Higher peak power capacity.

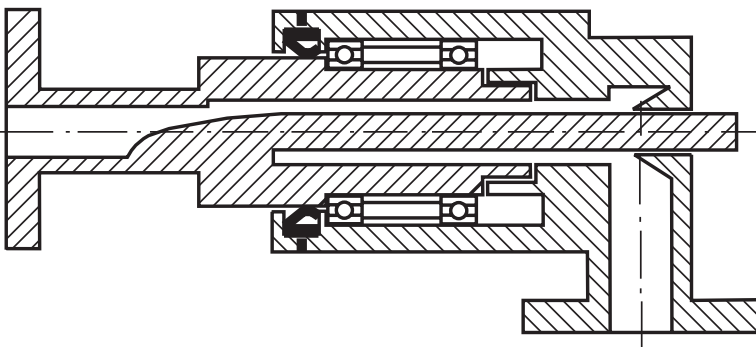

Figure 9.17 A cross section of a less typical rotary joint. Ball bearings and rubber sealing are used. The probe feed for the vertical waveguide converts itself into a fin, which generates the TE-mode for the horizontal line (going to the left) [13].

9.6.3 Coaxial Rotary Joints

In principle, coaxial rotary joints can be classified into two groups: (1) hollow shaft rotary joints and (2) contacting rotary joints.

In a hollow shaft rotary joint the inner conductor of the coaxial line is hollow, which allows coaxial cables to be put through the waveguide part. The ball bearings are the only mechanical contact between the rotating and static parts. There are several geometrical variations on this joint type. One alternative is a relatively thin model (see Figure 9.18) if there is limited room for the construction.

In contacting rotary joint models the electrical contact is maintained by utilizing precious metallic sliding contacts. The main reason for this is to realize a very wide operating frequency range. Mechanical wear is considerably larger and thus the total lifetime will be much shorter than in the non-contacting types.

9.6.4 Dual Channel Rotary Joints

In principle, these constructions are composed by combining a waveguide rotary joint module with additional coaxial or waveguide modules as shown in Figure 9.19. In this particular construction the waveguide center conductor will be used as the outer conductor for the next module.

9.6.5 Multichannel Rotary Joints

By using the hollow shaft of a waveguide module for coaxial cables a number of coaxial modules can be stacked to form a complete assembly with several low power channels.

In many rotary joint constructions the characteristic property that allows the turning of an antenna is used either for microwave transmission or for control or alignment purposes (e.g., various antennas).

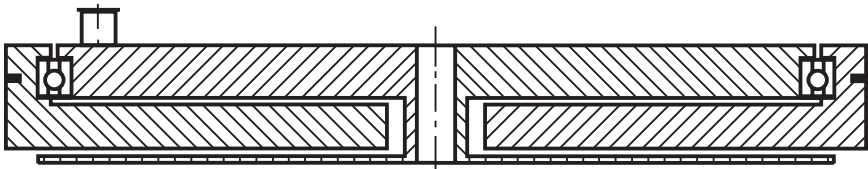

Figure 9.18 One example of the hollow shaft rotary joint. This model is relatively thin though the horizontal diameter is respectively larger [13].

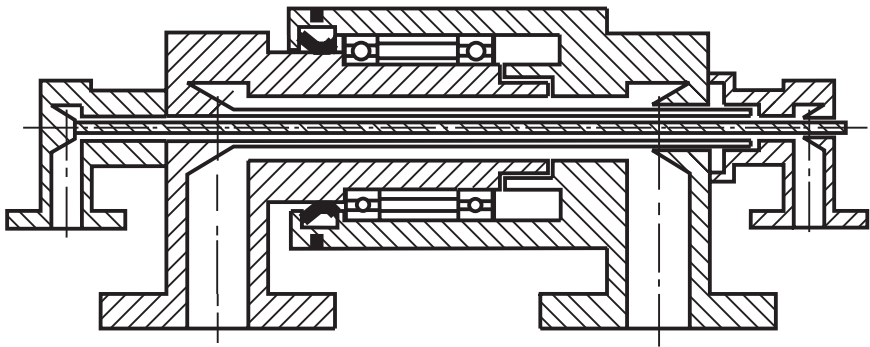

Figure 9.19 An example of a dual channel rotary joint. The two different waveguide sizes indicate that this device is suitable for two frequency bands, (e.g., K and X). All four couplings apply the electric-field-probe concept [13].

This means that high precision slip-rings are necessary. The most harmful effect will be stacking, which can be avoided with a proper material selection only.

During rotation the rotary joint will add some noise at a very low level because of small changes in its insertion loss and electrical phase. The joint itself can further cause some vibration. This fact sets special requirements for designing the mechanisms of the joint. Also temperature stability is very important for the performance. Thus we have to consider the materials and the heat conduction properties of the joint body carefully.

There are some rules of thumb for the mechanical design of a rotary joint:

- The lifetime depends on operating temperature, rotation speed (in typical applications from 1 to 2,000 rpm), internal barometric pressure, and other mechanical loading conditions.
- For most sophisticated rotary joints, even 50 million revolutions are guaranteed without maintenance.
- In many cases, the maximum starting torque of rotation is critical.
- To avoid extra loads and bending, flexible waveguides for further connections from the joint are recommended.
- As in many microwave applications, environmental loads set extra requirements (in this case mostly for the bearings, sealing, and sliding elements).

Typically, the surface roughness for a bearing assembly is $0.8 \mu\text{m}$. However, the requirements for the geometrical tolerances are even more critical. These values must be related to the dimensions of the bearings. Therefore the requirements are usually presented as a combination with the used tolerance grade (IT-grade). In this case, we have a good reason to require the following tolerance values (e.g., for bearing housings):

- Circularity IT5;
- Cylindricity IT6/2;
- Dimensional accuracy IT5.

In many cases there are no problems to accurately manufacture the parts of the rotary joints by using CNC machines. The mechanical measurement system and quality control practices, however, must be in line with the overall process. We should, for example, be able to recognize errors not larger than a few micrometers.

Various parts of commercial rotary joints are manufactured by using several types of manufacturing technologies successively, (e.g., first casting then machining, or first extrusion and then machining). This is not always easy to harmonize. In addition, the assembly of the parts of the joint is an essential role—any attempts to achieve perfect manufacturing accuracy can be disturbed by careless assembly. There are some possibilities to check the assembly mechanically afterwards:

- For slow rotation speeds, acoustic emission can be utilized;
- For high rotation speeds, vibration analysis can be utilized.

Both of these technologies can also be used for controlling the need of maintenance through the lifetime of the rotary joint mechanisms. A direct microwave measurement is seldom practical or reliable due to the apparent need to have a second rotary joint for the decoupling of test cables.

9.7 Case Examples of Precision Machined Microwave Components

Let us pick up two very special examples of precision machined components for further discussion about manufacturing accuracy:

- High-Q SiO_2 whispering gallery mode resonator;
- Center conductor for a tubular coaxial filter.

9.7.1 High-Q SiO_2 Whispering Gallery Mode Resonator

Artificial low-loss single crystals have usually been used as raw materials for high-Q microwave resonators. Applications have been mainly based on the sapphire (Al_2O_3) single crystal that presents extremely low microwave losses and leads to the achievement of high spectral purity X-band sources. However, the pure quartz (5,102) single crystal is known as a good microwave dielectric presenting low dielectric losses and only a slight permittivity anisotropy. Moreover, due to the extensive use of quartz in piezoelectric transducers and resonators, high purity, well-orientated and low cost single crystals are easily available. These facts have given a good reason to try to apply the Whispering Gallery Mode technology to design also a SiO_2 microwave resonator. To ensure the desired performance relatively tight mechanical requirements are set to the manufacturing process of the metallic resonator cavity itself.

The mechanical construction of the cylindrical cavity according to Giordano [14] is presented in Figure 9.20. The inner diameter of the cavity is 80 mm and the respective height 20 mm. The base material is OFHC-copper, which is plated with gold. To avoid any possible disturbances in the cavity performance due to mechanical uncertainties, high precision machining is needed. This improves the Q-value of the empty cavity itself and makes it easier to control the appearance of unwanted wave modes. It should

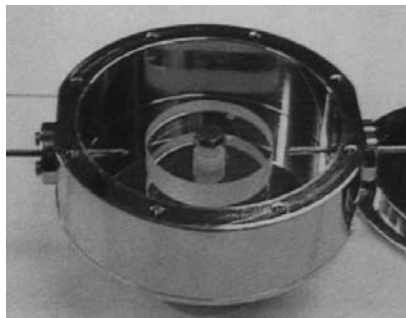

Figure 9.20 The mechanical construction of the cavity for a SiO_2 resonator. Material is gold plated OFHC-copper. Note that there is no real need from the microwave point of view to have the outer surfaces polished [14].

also be taken into account that conversely to the well-known sapphire resonators the sensitivity of the resonance frequency to temperature variations is mainly due to the thermal expansion of the resonator material. In this cavity, two radial magnetic field probes (loops) are used to excite both the quasi-TE or quasi-TM modes. They are located very precisely at the opposite sides of the cylinder. The mode family is determined by the position of the loop plane, which is for example perpendicular to the cavity axis for WGE mode excitation.

9.7.2 Center Conductor for a Tubular Coaxial Filter

Figure 9.21 presents a high quality center conductor for a tubular low pass coaxial filter. The operating principle relies on successive high and low impedance sections but must take into account the stray capacitances caused by the abrupt axial discontinuities. First of all it is necessary to emphasize that this component is completely machined out of one solid base part and thus involves no joints. There is also a chamfer on the left end of the axis and a rifling on the last end. This means that both turning and milling processes are necessary. A special balanced turning technology is needed for the manufacturing phases of this kind of a component. Well planed fixturing and supporting arrangements are to be used. One set of center conductor dimensions is presented in Table 9.1.

Difficulties that might be met during the manufacturing process are as follows:

- The large differences between the smallest and largest diameters needed to produce the desired impedance values may cause turning forces can either bend or twist the work piece.

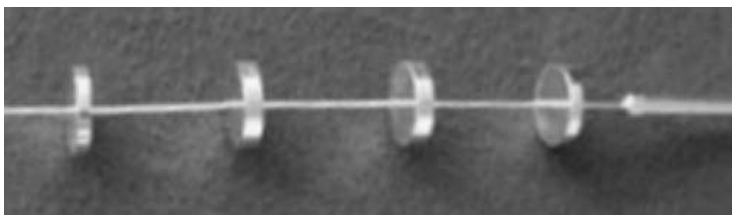

Figure 9.21 High precision center conductor for a tubular filter (manufactured by Tronser GmbH).

Table 9.1

Dimensions of the Center Conductor Presented in Figure 9.21

Property	Dimension [mm]
High Z diameter	0.80
Low Z diameter	13.60
Outer low Z length	1.30
Middle low Z length	2.10
Distance between middle low Z sections	12.00
Distance from the middle low Z to the outer low Z	11.00

- Due to the relatively small diameter in the high Z sections and the sharp-edged changes between the diameters of low and high Z sections special tooling is needed.
- Though dimensional accuracy and surface quality are relatively easy to achieve there can be problems with the geometric tolerances (circular or axial run-out, coaxiality, or cylindricity).

References

- [1] Kalpakjian, S., and S. Schmid, *Manufacturing Engineering and Technology*, New Jersey: Prentice-Hall Inc., 2000.
- [2] Wright, P. K., *21st Century Manufacturing*, New Jersey: Prentice-Hall Inc., 2001.
- [3] Matthaei, G., L. Young, and E. Jones, *Microwave Filters, Impedance, Matching Networks and Coupling Structures*, New York: McGraw Hill, 1964 (reprinted 1990).
- [4] Eskelinen, H., P. Eskelinen, and K. Tiuhonen, "Application of Concurrent Engineering in Innovative Manufacturing and Design of a Milled Microwave Filter Construction," *Proc. 4th Int. Conference Managing Innovative Manufacturing*, Birmingham, UK; Jul. 17–19, 2000, pp. 230–236.
- [5] Eskelinen, H., "Developing Computer Aided Design Environment for Microwave and Radio Frequency Mechanics Design," *Engineering Mechanics*, Vol. 8, No. 5, 2001, pp. 343–351.

-
- [6] Eskelinen P., et al., "The Effects of Some Mechanical Uncertainties on the Performance of Welded and Machined Phased Array Antennas," *Proc. ICAP'01*, Manchester, UK, 2001, pp. 821–824.
- [7] Ludwig, R., and P. Bretchko, *RF Circuit Design*, New Jersey: Prentice-Hall Inc., 2000.
- [8] Eskelinen, P., et al., "A High-Isolation S-band Ring Hybrid Combiner," *Proc. EuMW 2001*, London, England, Sept. 25–27, 2001, pp. 173–176.
- [9] Ahn, R., and I. Wolff, "Small-Sized Ring-Hybrid Phase Shifters," *Proc. MIOP'01*, Stuttgart, Germany, 2001, pp. 284–288.
- [10] Schallner, M., and W. Konrath, "Fully Automatic Laser-Adjustable Planar Ring Resonators as Replacement for Dielectric Resonators," *Proc. MIOP'01*, Stuttgart, Germany, 2001, pp. 279–283.
- [11] *Suhner RF Connector Guide, Understanding Connector Technology*, Huber and Suhner AG, Switzerland, 1996.
- [12] *Suhner Coaxial Connectors General Catalogue*, Huber and Suhner AG, Switzerland, 1999.
- [13] Sivers Lab A (Chelton Group Company), *Rotary Joints and Switches, High Precision Mechanical Microwave Products*, Upsala, Sweden: Wicström, 2001.
- [14] Giordano, V., et al., "High-Q SiO₂ Whispering Gallery Mode Resonator," *Proc. Int.Symposium The European Frequency and Time Forum and the IEEE Frequency Control*, Apr. 13–16, 1999, Besancon, France, pp. 593–596.

10

Cutting Processes

10.1 Sheet Metal Cutting In General

Soon after the introduction of commercial circuit board materials and associated manufacturing processes, their use was extended to stripline and microstrip constructions. These materials and manufacturing processes were extensively studied by the 1950s (despite the lack of sensible opportunities for volume production) both as a convenient means of merging active components and distributed lines and as a way to create miniature passive modules. This development process was further accelerated by the invention of high-permittivity dielectrics and could soon be applied at several tens of gigahertz.

Many high-power or low-loss microwave and radio frequency applications, however, including radar transmitters or receivers and broadcasting equipment, cannot use solely passive constructions (such as power dividers, couplers, and filters), which are based on printed circuit board solutions. The reason for this is either the limited thermal or dielectric breakdown characteristics or, occasionally, excessive transmission losses (which are particularly annoying if lowest possible receiver noise figures are desired). An alternative approach is to construct transmission lines from thin metal sheets, for example, whereby a considerable reduction of weight and cost is generally anticipated when compared to waveguides or milled designs. Of course, one of the key tricks is air (the second best dielectric) around the sheet strips—a solution which, in addition to giving very low attenuation values, is completely free in all quantities. The application of sheet metal constructions can thus be

easily pushed into the rapidly expanding mobile telecommunication electronics business. For planar stripline or microstrip designs, various modern sheet metal processes seem attractive, particularly laser cutting and, to a certain extent, water jet cutting. A brief initial comparison of different metal cutting processes suitable for microwave mechanics is presented in Table 10.1.

When the typical dimensional uncertainty requirements, materials, sizes of manufactured units, and finally the anticipated production volume are all combined, many of the listed technologies must be rejected. According to our experiences, punching or nibbling, despite their relatively high production speed, are not very attractive manufacturing technologies for the mass production of microwave modules. Their tooling costs are high for difficult geometries and sometimes their cutting quality is insufficient, which is particularly observed as bends and burrs in the punched edges. Flame processes are typically far too rough with respect to the test piece dimensions and only dedicated equipment having the lowest possible heat output is suitable for the thin materials needed. Almost anything could be produced by numerically controlled milling but—while known since the days of World War II to be able to provide better-than-adequate quality—this path is both tedious and expensive.

If aiming at microwaves, a thorough reconsideration of cost-effectiveness and sheet metal volume production is necessary. The final choice of the cutting

Table 10.1

Comparison of Different Cutting Processes in the Framework of Microwave Mechanics

Cutting Technology	Fundamental Difficulties
CNC machining	Cost, waste of time
Pressing	Inadequate accuracy, tooling
Nibbling	Inadequate accuracy, tooling
Punching	Inadequate accuracy, tooling
Flame	Distortion
Plasma	Distortion
Water jet cutting (abrasive)	Surface roughness of the cut edge
CO ₂ -laser cutting	Reflective materials
Nd:YAG-laser cutting	Extra work is needed for finding optimized laser process parameters for each new application

process must naturally provide a technically and economically feasible match between the fundamental performance requirements of the target microwave component and the achievable mechanical processing accuracy (see Figure 10.1). It is also necessary to notice that in many radio frequency applications the required tolerance grade of the mechanical cutting process is above the typical possibilities of so-called “high precision” technologies (see Figure 10.2) particularly in volume production. This problem is further complicated by the different characteristics observed either along the direction of wave propagation or perpendicular to it. For example, as a first approximation, the characteristic impedance Z_c of a stripline does not depend on the operating frequency and thus the cross-sectional tolerances are defined by the initial Z_c and the physical size of the dielectric but on the other hand the length of the strip is connected to the frequency whereby at higher microwaves the tolerances applied to strip get smaller and smaller. An electrical phase error of one degree is equal to 0.8 mm at 1 GHz but the same angular offset at 30 GHz requires precise cutting where an error of $30 \mu\text{m}$ may be too much.

In order to show the practical importance of a proper choice of the cutting process and to be able to compare the real impact of cutting quality on

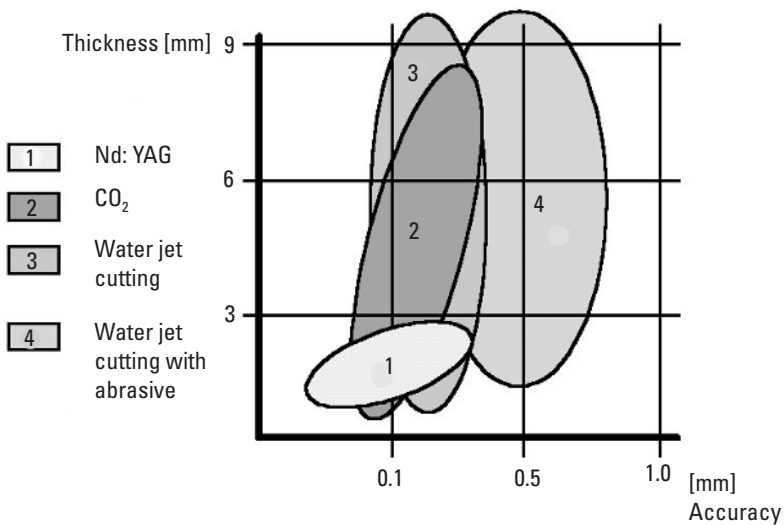

Figure 10.1 A comparison of best achievable cutting accuracy for different mechanical cutting processes. Vertical axis shows typical material thickness. Practical workshop results may in the worst case differ by a factor of two or three.

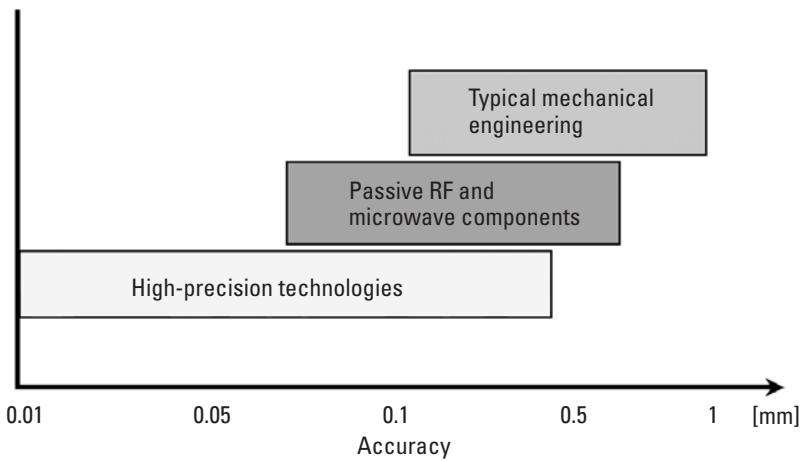

Figure 10.2 Comparison of general tolerance requirements in mechanical engineering. Also many high precision technologies may fail in providing the wanted microwave performance particularly above 10 GHz.

the performance of selected UHF and microwave components, we have designed, manufactured, and tested several common products:

- Center conductors of low-loss planar power dividers (both rectangular bends and ring hybrids);
- Microstrip feeding networks for S-band communication and radar;
- Antenna elements;
- Stripline bandpass filters;
- Coaxial transitions in which cutting is used as a tuning method.

Key results, some illustrative examples, and suggestions for practical arrangements in production are presented in the next three chapters both for laser cutting and water jet cutting.

10.2 Water Jet Cut Striplines and Microstrips

10.2.1 A Water Jet Cut Ring Hybrid

In order to evaluate the intrinsic suitability of water jet cutting for serious RF work, several samples of a conventional 1.2- to 1.8-GHz four-port ring

hybrid were designed and constructed. The device works well as a part of antenna power distribution networks and as a TX/RX multicoupler but its proper operation requires relatively strict mechanical accuracy. Particularly vital is the width of the circular strip, which theoretically should present a characteristic impedance of 71. All four coupling arms are assumed to be terminated to 50. Both copper and aluminum sheets were tested and a commercially available termination was utilized at port four. The elementary mechanical layout of the center conductor is presented in Figure 10.3.

In this case, water jet cutting, particularly with abrasive particles, seems to give considerably better results than CO₂ lasers both in terms of structural symmetry and edge quality. However, even though water jet cutting basically

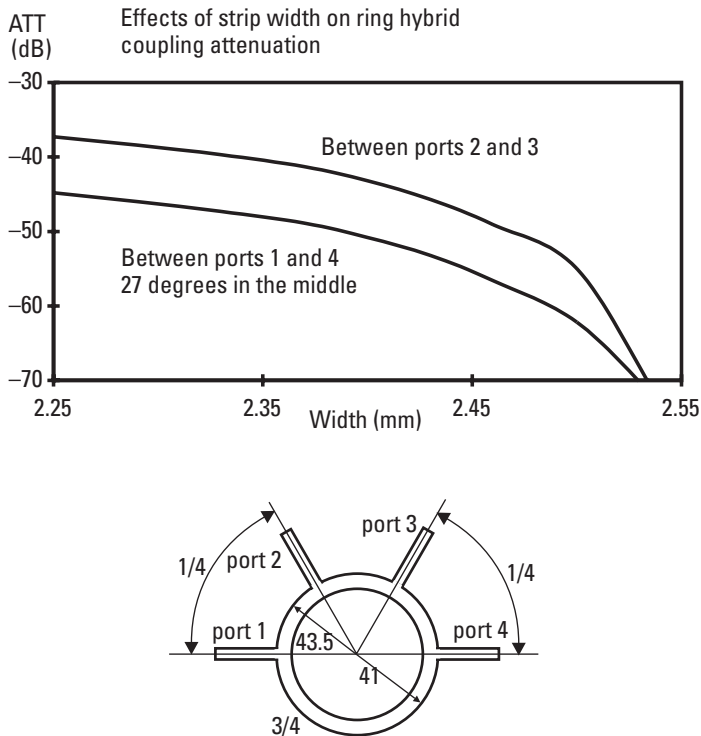

Figure 10.3 Effects of strip width on ring hybrid coupling. Pairs 1 through 3 and 2 through 4 should theoretically have infinite attenuation but even short portions of improper width can cancel it. A practical limit with copper center conductors was observed near -70 dB and units as poor as -27 dB were recorded. The principal geometry of the tested ring hybrid and associated $50\text{-}\Omega$ coupling arms are presented on the bottom.

looks promising, some worst-case errors might still be able to destroy the ring hybrid performance. Figure 10.4 shows highly magnified photos of the inner surface section of selected hybrid center conductors made of AlMg3 aluminum alloy. It seems that current automatic control technologies have serious difficulties in maintaining, for example, a constant turn radius when the jet is used to separate the ring from the base material. This will cause severe fluctuations of the strip width, which in turn has an adverse impact on the line impedance. The effects of these faults on the microwave performance are easily predicted through the application of simple transmission line theory, the results of which are illustratively presented in Figure 10.3. The whole manufacturing attempt will usually collapse if the processing uncertainty (in this case, for example, jet positioning error) exceeds about 10% of the design dimensions.

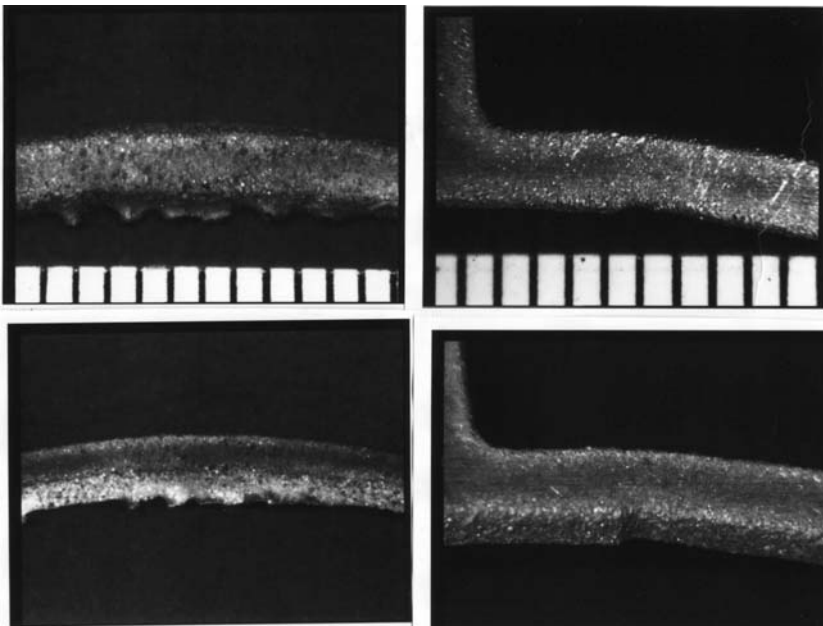

Figure 10.4 Close-up photos of the inner surface of the aluminum center conductor. The average area of the jet starting (or ending) points—observed as tooth-like burrs along the inner edge (top)—is 0.5 to 1.5 mm². The flaw area due to improper water jet parameters (bottom) is again 0.5 to 1mm². The radio frequency effects of this fault type are generally more serious because of the greater transmission line distance involved [1].

10.2.2 A Water Jet Cut Stripline Feeding Network

Dimensional manufacturing accuracy problems also appear in various modern base station or radar antenna designs involving sheet aluminum feeding strips either as simple microstrip arrangements or as complete striplines with double ground planes (see Figure 10.5). In this case we normally don't have to worry about the cutting edge itself but maintaining the desired overall shape and lengthwise dimensions can be a challenging task indeed. If extreme performance is looked for, an appropriate compromise of materials and cutting technologies may well turn out impossible or at least impractical. When the overall physical size of the piece gets larger it is important to consider the whole manufacturing chain including the final assembly stage.

In addition to difficulties in producing an adequate edge quality and reasonable width tolerances, bends and kinks in all imaginable directions are to be expected if the overall dimensions of the sheet metal component exceed a couple of wavelengths. Not only improper manual handling but also the successive variations of internal sheet tension due to the cutting forces and friction heat should be taken into account. Because these feed structures are normally applied in lightweight antennas we must be aware of the low inherent stiffness of the supporting enclosure which often is just a quite flexible aluminum frame covered with some enforced plastics.

10.3 Laser Processed Feeding Strips

Basically, the very same geometries as discussed above in conjunction with water jet cutting are suitable for laser processing as well. However, a difficult limitation is caused by the optical characteristics of the most attractive (in terms of microwave performance) materials, which tend to absorb only small fractions of incident laser power.

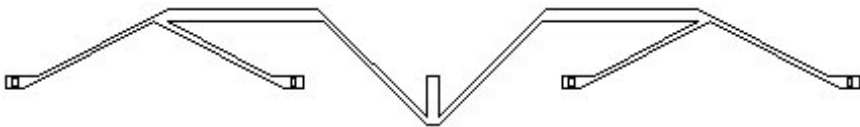

Figure 10.5 A typical water jet cut feeding strip geometry for an S-band antenna feed construction. The total length of the strip is 246.00 mm and the minimum width (which is needed in the quarter wave transformers) is 1.70 mm. The problems here are partly related to the V-shaped angles and partly to the frustrating attempts to maintain a planar structure [1].

10.3.1 Laser Cutting Process in General

Different laser cutting processes are used for profile cutting, cutting in-line chifts and for tube cutting. Also complicated contoured profiles can be handled. The most important advantages of laser cutting are a small kerf width and a narrow HAZ. The cut also has parallel sides (less than 2% edge taper). No secondary manufacturing methods are normally needed for finishing the cut edge, which is square and not rounded as it would be with most other thermal processes. There is no edge burr either—unlike with mechanical cutting technologies. These properties are of high importance in microwave mechanics.

Even though industrial lasers are still most cost-effective for cutting, we should be interested in enlarging their possibilities into multiprocessing applications. One such dedicated scheme of great interest is the laser cut-weld. Another important multiprocessing system is the cut-bend-weld (laser combined with a conventional manufacturing method). These flexible manufacturing systems tend to grow naturally in multistation cells and their aggregation is in isles and complete manufacturing centers.

Slow axial flow CO₂ lasers (SAF) are among the best for cutting. FAF CO₂ lasers with a DC-excitation and a stable resonator are suitable for fine and macro cutting. Slab lasers are very good for all cutting processes. High-power Nd:YAG lasers are suitable for high quality cutting.

When choosing the optimum laser cutting process for a specific task the following alternatives and topics should be considered:

- Laser sublimation cutting—material is removed by evaporating the metal, and hardly any melting occurs which means smooth cuts;
- Laser fusion cutting—material is melted and blown away with an inert gas jet;
- Laser flame cutting—instead of inert gas, pure oxygen is used, and high process speeds can be achieved.

The following facts should be taken into account when designing a laser processed microwave product:

- Typical surface roughness for material thicknesses between 1 and 3 mm will not be better than $R_a = 0.8 \mu\text{m}$.
- Typical accuracy is only about 0.1 mm, but with appropriate cutting parameters and ideal materials 0.03 mm can be achieved (expensive tests are usually required) by skilled operators.

- Cutting results mainly depend on beam quality (e.g., the spatial power distribution of the beam) and expertise of personnel.
- For highly reflective materials (such as copper and aluminum), Nd:YAG is recommended instead of CO₂ (due to smaller wavelength of Nd:YAG).

10.3.2 A Laser Cut Sharp-Edged Center Conductor

A traditional low-loss, 1 to 3 GHz, Wilkinson-type power divider, which is documented, for example in [2, 3] as a printed circuit board version, was designed to have a milled enclosure acting as a double ground plane combined with a cut, Y-shaped sheet aluminum center conductor. The constructed divider prototype is shown in Figure 10.6 together with the measured attenuation performance, which suggests a fairly good success with an S_{21} near 3.2 dB across the whole frequency band.

Here our initial observations suggest that a standard CO₂ laser sheet cutting process is not able to maintain the required positioning uncertainty over the whole length (about 100 mm) of the center conductor. This is

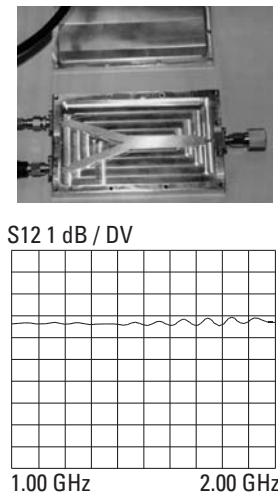

Figure 10.6 The prototype divider opened for inspection (top). The dimensions and the basic geometry of the Y-shaped center conductor are as follows: total length 93.00 mm and total width 35.00 mm. A precise cutting track was particularly hard to obtain along those edges where the laser system could not follow the principal axes. There are no supports or solder joints for the center conductor except the press-fitted connectors at each end of the enclosure, which yields a very low residual attenuation (bottom) and good impedance match [4].

clarified with the actual measurement results and the simulated behavior of the sum port scattering parameters in Figure 10.7. Further on, CO₂ lasers tend to produce a burred edge due to the spraying of melted metal along the beam direction. Use of Nd:YAG laser has given much more promising results both regarding symmetry and edge quality but it seems to be better suited for aluminum than copper. The use of pulsed laser improves the sharpness of the cut edge. This gives a better way of controlling the electrical length of the quarter wave arms whereby the total input impedance of port 1 can be brought closer to 50Ω.

Our experimental results indicate that an Nd:YAG laser should also be used (e.g., for interdigital stripline filter constructions) when the material thickness is on the order of 0.5 mm. This will ensure that the vertical edges of the center conductor are sharp enough and perfectly perpendicular to the ground plane. Neither the CO₂ laser nor water jet cut seem to give acceptable results here.

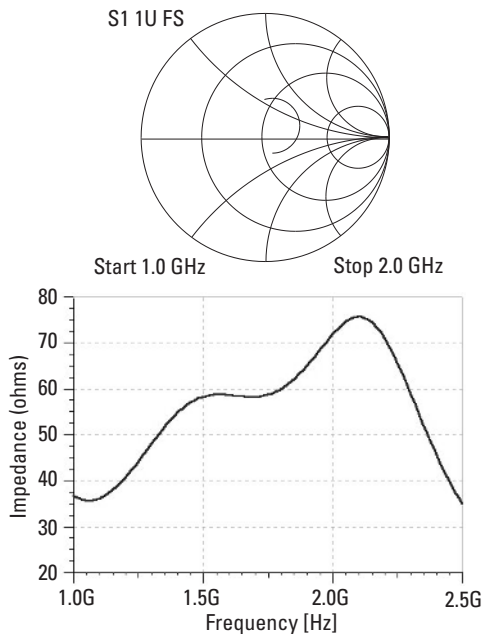

Figure 10.7 If not properly tuned, the process parameters of CO₂ lasers will not provide an optimum fit with the material, which causes an impedance mismatch due to the nonsymmetric center conductor. The measured (top) and simulated (bottom) results of the sum port agree and indicate an overly high transmission line characteristic impedance [1, 4].

10.3.3 Laser Cut Striplines for Low-Loss Interdigital Filters

Most passive radio frequency components are of mechanical construction and their cost may exceed 20% of the product's total value. Additionally, much of the weight of communications, radar, and signal processing systems and their individual components is attributed to mechanics and thus a minimal size is highly desirable. Most passive modules that employ distributed elements (e.g., couplers, filters, antennas) are forced to obey the theoretical constraints of length along the direction of wave propagation (e.g., $1/8$ or $1/4 \lambda_g$ or integer multiples of these) and so only the cross section is available as a way to volume reduction. One extreme special case is the interdigital stripline radio frequency filter [2], the performance of which is actually based on physical dimensions and materials only. In this design, conducting "fingers" are mounted between two parallel metal surfaces and the conductor width together with the insulating material creates various, suitable impedance values.

The traditional manufacturing practice, (e.g., see [2, 3]) for a nice product from the early 1950s, selected by radio engineers, favors milling of brass or aluminum followed by tedious manual assembly but suffers from cost and performance limitations. When searching for a solution to shrink the dimensions, without seriously sacrificing performance, scientists have considered active circuit implementations and have initiated a desperate hunt for new substrates. Fundamentally, microstrip technology would offer a very compact approach at least above 1 GHz. However, many studies must unfortunately admit that attenuation in normal thin-films usually prevents a narrowband design and would be particularly harmful because of the increasing receiver noise figures. This is obvious due to the losses in the selected dielectric material. Also the radiation from the upper side of an asymmetric line is hardly avoidable.

Some simulations, which were already briefly introduced in Section 2.1.2, suggested that highly selective, low-loss filters (e.g., for cellular base station networks) could alternatively be based on very thin sandwich-style sheet metal structures featuring 3-dB bandwidths up to 100 MHz and a passband attenuation below 0.3 dB. These all-metallic devices would be capable of withstanding the most stringent environmental stresses in corrosive tower installations, and the generation of unwanted propagation modes could be prevented—a complicated task with waveguide structures. Required, practical manufacturing and assembly tolerances in the mechanics workshop, however, are relatively strict.

Let's now consider the versatile possibilities of utilizing laser cutting for manufacturing the striplines. The final electrical design including the three shorted resonators is shown in Figure 10.8, which illustrates the individual

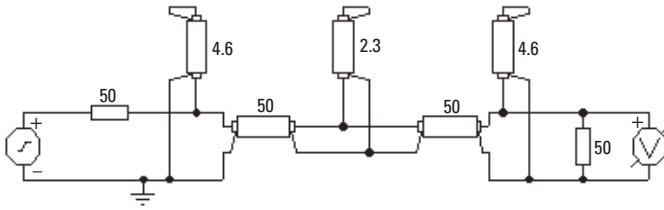

Figure 10.8 The electrical simulation model for a stripline bandpass filter. In practice, each section of transmission line (modeled as a coax) will be a short steel sheet placed between two parallel conductive layers. The sheet length and width are the two critical dimensions, which should be carefully cut with the laser.

terminating impedances and the test generator as well. The reader is reminded about the general design practice which allows us to model each transmission line as, for example, a coaxial stub (the applied symbol in the drawing!) as long as we restrict the analysis to circuit theory and omit any studies of internal electromagnetic fields. The respective simulated behavior of S_{21} can be seen in Figure 10.9 including the effects of some parameter variations. Figure 10.10 shows the obtained theoretical line impedance as a

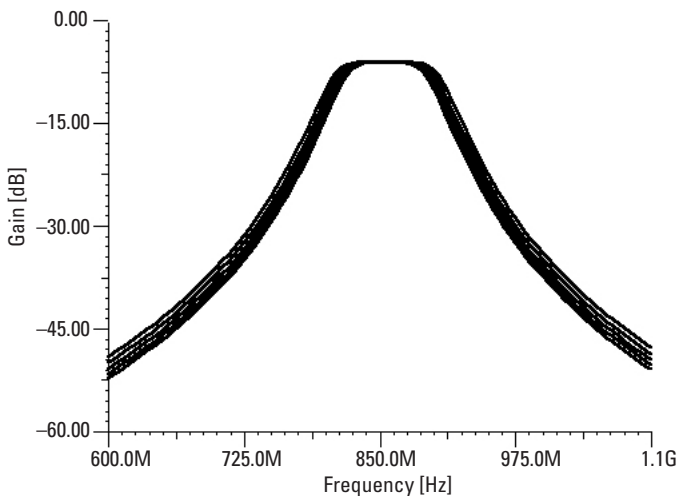

Figure 10.9 The simulated behavior of an interdigital sheet metal stripline filter including the effects of the middle impedance parameter. A 100-MHz passband is easily obtained if 0.5 mm sheet can be used. The thickness of the plate is one of the most critical variables for laser cutting as well, due to the edge quality requirement.

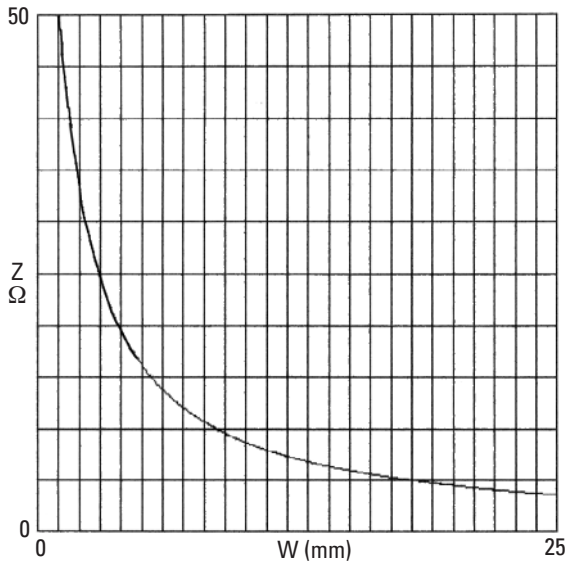

Figure 10.10 The characteristic impedance of the filter sections is based on the width of the metal strip. At high impedance levels, a very narrow strip is used and its sensitivity to parameter variations is considerable. Strip thickness is 0.5 mm. The importance of the exact width of the laser cut strip should be self-evident.

function of steel strip width. The parameter sensitivity particularly around the nominal 50- Ω characteristic impedance is very sharp and will be even worse towards higher impedances. On the other hand, a very low Z_c (typically below 10 Ω) may create difficulties because the strip width is no longer negligible compared to the wavelength. If ignored, this feature will yield to transversal modes.

The basic mechanical layout is demonstrated in Figure 10.11 for a third-order Butterworth response. The 0.5-mm stainless steel plate (which yields a smallest strip width of just 1.00 mm) proved to be almost ideal for laser cutting, but special jigs were still necessary in order to prevent excessive bending. Guide pins and associated holes could be used along the exterior of the center conductor to facilitate a reasonably easy assembly process.

The transmission line impedances could be readily fine-tuned later, if necessary, by laser trimmed sections but excessive thermal stress must be avoided and a repeatable assembly scheme should then be available. Suitable center frequencies cover most known analog and digital phone systems including the universal mobile telecommunications system (UMTS) and 3G at or near 2 GHz. The simultaneous application of sheet metal structures and

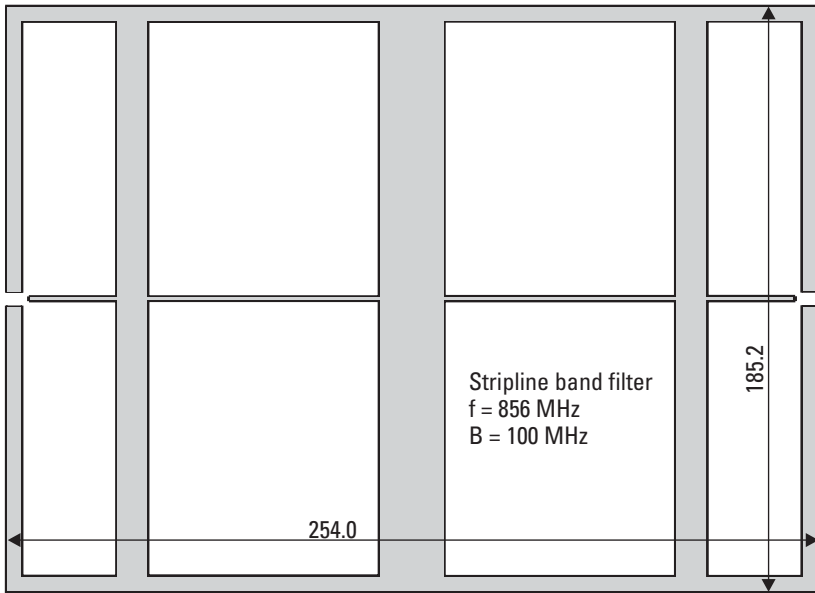

Figure 10.11 The principal mechanical layout for a third-order Butterworth filter's center conductor constructed from a 0.5-mm steel sheet. The main propagation path goes in the middle from left to right and SMA connectors were laser welded to the respective ends of the thin horizontal strip.

intelligent laser processing techniques for the manufacturing of these microwave modules could improve production yield. Also in this case we can achieve sharper resonator corners by using Nd:YAG laser cutting. New performance levels and cost reductions look feasible due to the possibility of interactive design changes, improved surface quality, stability, or the use of sophisticated materials. The detailed manufacturing documents can be found on the attached CD-ROM.

10.4 Tuning Coaxial Transitions

Most active microwave modules operating below 40 GHz, almost all commercial interfacing connectors, and often short to medium length transmission lines as well are of coaxial nature. On the other hand, many antennas and long transmission lines are based on waveguides. Thus an efficient coupling structure is needed to feed a hollow rectangular or circular waveguide from a cable or vice versa. Typical basic realizations include the common

small magnetic loop (which is a short circuit for DC) and the short electric rod arrangement. In principle, a short conducting rod placed in the middle of a rectangular provides a well-known and easy way to excite a TE_{10} mode and can be tuned for a good impedance match by varying its length and the distance to the short circuited end. Key parameters of the transition are its impedance matching, which can be improved by nearby shorted pins and the generation of wanted propagation modes only. A reasonably wide bandwidth is often desired at a later time, usually exceeding 5 to 10% of the nominal center frequency.

Several suitable approaches for a waveguide transition design are presented in the literature, introducing both theoretical results and measured data for a specific construction but generally means to meet the requirements for cost effective manufacturing are ignored. Most often, only a statement of careful waveguide dimensioning is made based on the upper limit of the operating bandwidth of the transition. It is also common to list salient features of proposed designs such as low manufacturing costs, hermetic sealing of the interface, simple electrical or mechanical design and relatively broadband performance with a low insertion loss. No doubt these facts are the most vital ones, but for a mechanics designer it would be even more useful to know how the expected features can be achieved in a real product.

From the manufacturability point of view, the tuning of the transition (or more precisely its scattering parameter S_{11}) is complicated due to the need to cut the rod to a suitable length l after it has been installed in the waveguide. If the guide is open from one end, as is the case with horn antennas and waveguide adapters, a post-mounting cut would be highly attractive. Since the transition is usually deep inside the antenna structure, however, no mechanical means exist to perform this adjustment. Cutting with a laser beam would provide an interesting alternative but the actual shape of the cut depends on the selected process as well. Very little has been published about the possible electrical effects of a nonplanar end surface of the feed probe.

As a case study, four different coaxial transitions were manufactured in order to simulate the effects of the rod's actual shape. They were all tested in a sample Ku-band horn antenna having a +1.0 mm feed displacement. The close-up photographs in Figure 10.12 show the end shapes of actual feeds which are a straight-edged one as a reference and a tilted, grooved, and ball-shaped one (simulating the possible manufacturing errors). The same mean length was maintained in order not to disturb the tuning. Measured differences exceeded our expectations. As indicated in the Smith chart of Figure 10.13, the best performance is obtained with the "perfect" straight-ended rod having an input impedance $Z_{in} = (36.7 + j 8.9) \Omega$ and the worst

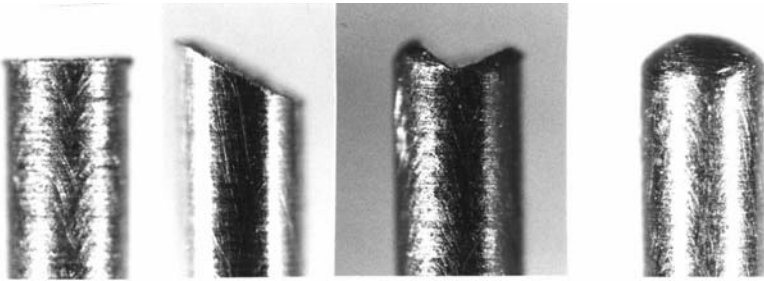

Figure 10.12 Microscopic photographs of the four tested coaxial transition rods [5]. Manufactured from a commercially available prolonged-dielectric SMA-type connector, we have (starting from left) a straight, a tilted, a grooved and a ball-shaped feed rod end.

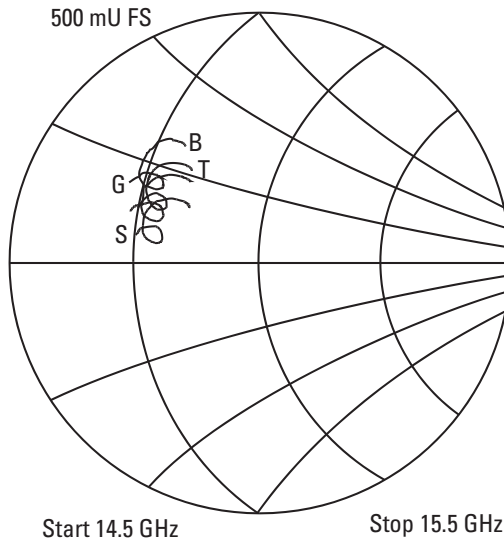

Figure 10.13 The magnified Smith chart presentation (0.5 U full-scale deflection) of the effects of the end shape found in coaxial transitions (S = straight, T = tilted, G = grooved and B = ball-shaped). The best electrical performance is obtained with a straight-edged rod (S) whereas a ball-shaped version (B) provides the worst impedance match, which is caused by the excessive inductance [5].

with a ball-shaped end where the $Z_{in} = (33.4 + j 17) \Omega$. The tilted and the grooved feed rods behave about the same and fit in between the two extremes across the entire 1-GHz measuring bandwidth.

References

- [1] Eskelinen, H., P. Eskelinen, and K. Tiihonen, "Novel DFMA-Tools for Passive MW- and RF-Components in Cost-Effective Mass Production," *Proc. 30th Int. EuMW-Conference*, Paris, France, Oct. 3–5, 2000, pp. 88–91.
- [2] Matthaei, G., L. Young, and E. Jones, *Microwave Filters, Impedance, Matching Networks and Coupling Structures*, New York: McGraw Hill, 1964 (reprinted 1990).
- [3] R. Collin, *Foundations for Microwave Engineering*, New York: McGraw-Hill, 1992.
- [4] Eskelinen, H., and P. Eskelinen, "Manufacturability of All-Metallic Passive High Power Rf Components In Volume Production," *Proc. XXIV URSI/IEEE Convention on Radio Science*, Turku, Finland, Oct. 4–5, 1999, pp. 20–21.
- [5] Eskelinen, H., "Suggestions for Finding Optimum Materials and Manufacturing Methods for Metallic Microwave Cavity Resonators," *Proc. 13th European Frequency and Time Forum and 1999 IEEE International Frequency Control Symposium*, Besancon, France, Apr. 13–6, 1999, pp. 567–572.

11

Forming Processes

11.1 Extrusion Processes for Metallic Profiles

Hollow rectangular or elliptic (including completely circular, of course) waveguides are typical items for extrusion. During an extrusion process, a billet is forced through a die. In general, various kinds of solid or hollow cross sections can be manufactured by extrusion processes. In many cases, the quality is acceptable without any postprocessing, at least for semiproducts. Since the die geometry remains the same during the continuous extrusion process, the applications should preferably have a constant cross section. Therefore, it is typical that extruded products of different size and shape must be cut into desired lengths from which the final design can be assembled. The most frequently used extrusion processes are direct, reversed, hot, cold, impact, hydrostatic, and so-called coaxial extrusion. To reduce the forces needed for extrusion (actually depending on the ductility properties of the material itself), extrusion can be done at an elevated temperature. Commonly extruded materials are aluminum, copper, steel, several kinds of plastics, magnesium, and lead. The most important material property to meet appropriate quality in extrusion is ductility.

During the direct extrusion process, a billet is placed in a chamber and it is forced through a die opening by a hydraulic stem. The term “reversed extrusion” comes from the simple difference that here the die moves towards the billet. During the hydrostatic extrusion process, a chamber, which is filled with a fluid, is used. A pressing stem forces the fluid inside the

chamber, which then pressures the bulk. The most significant advantage of hydrostatic extrusion is that, due to the compressive environment, the defects in the extruded product can be reduced. It also makes it possible to extrude even some brittle materials (e.g., thermal insulators in microwave applications).

Hot extrusion is used simply for materials that do not have sufficient ductility at room temperature. The use of higher temperatures reduces the required extrusion force as well. Unfortunately, when thinking about microwave devices, a hot extrusion process develops an oxide film on the surface. This usually decreases the material's surface and electromagnetic properties. To avoid this, special arrangements are needed (e.g., an inert atmosphere). Another negative by-product of increased flexibility is the fact that both the surface quality and dimensional tolerances are far from the level of cold extruded products.

If cold extrusion can be utilized instead of hot extrusion, better dimensional tolerances and decreased surface roughness are achieved (in many cases, no postprocessing is necessary) In addition to these advantages, no oxide layer is formed on the surface and better mechanical properties (due to work-hardening) are achieved.

During a coaxial extrusion action, two billets are extruded together. An example for microwave mechanics is an extruded copper semiproduct clad with silver. A second important process in microwave mechanics is lateral extrusion. It is suitable, for example, for coating wires or cable parts with plastics. During impact extrusion, a punch descends rapidly on the blank. Typical manufactured geometries are cylindrical workpieces with some special end shapes, such as insulator elements of coaxial RF connectors.

For practical work, it is important to notice that for steels, the extrusion forces are larger which means that the circumscribing circle diameter (CCD) parameter (diameter of the smallest circle in which the cross section fits, see Figure 11.1) is about 60% smaller than for other materials. For steels, higher extrusion speeds are also recommended compared to titanium and refractory materials. If no special arrangements are used, the dimensional tolerances are not better than 0.25 mm. The dimensional tolerances, however, are related to the size of the cross section. In case tubes or hollow cross sections are extruded, the ones with thin wall thicknesses are most difficult (typical minimum value for aluminum is about 0.8 mm). During the extrusion process, the most important process parameters are extrusion force, extrusion speed (up to 0.5 m/s), die geometry (die angle), extrusion ratio (reduction of the cross section, usually 10...100), shape factor (describes the complexity of the extruded cross section), CCD parameter (for aluminum typically max. 0.25),

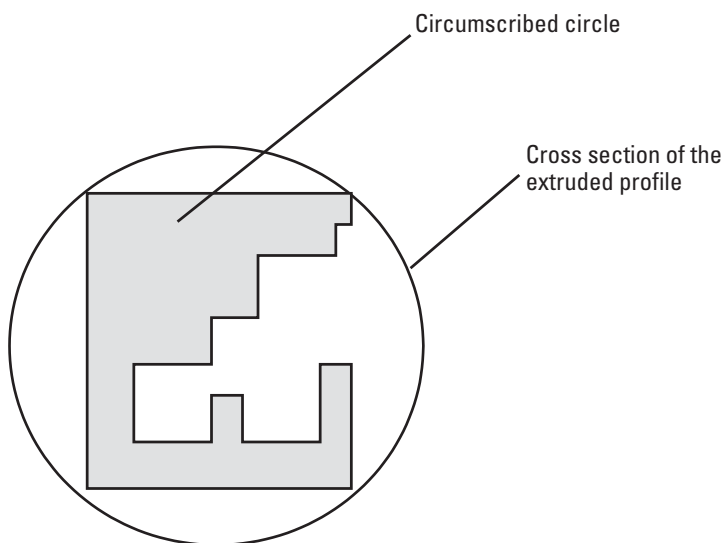

Figure 11.1 CCD parameter describes the diameter of the smallest circle in which the extruded cross section fits.

and temperature. Material properties are taken into account with an extrusion constant (material parameter) and friction coefficient against the extruded cross section and material flow pattern. The die wear is also measured.

For a practical comparison of various manufacturing technologies, it is important to notice that although extrusion provides the advantages of a continuous process, the costs for die design and materials are quite significant. One should also take into account that the same die cannot be used for every material to be extruded. Due to different adhesive surface properties, they tend to stick more or less on the surface of the die and the chamber. To avoid this, either an appropriate lubricant should be used, or a new die material should be selected. Three main types of defects which can take place during extrusion processes are surface cracking, so-called funnel phenomena, and internal cracking. If the surface temperature rises significantly, friction is too high, or the extrusion speed is too high, then there is a risk of surface cracking. The surface is “teared.” The other possibility is the aforementioned sticking of the surface. This is more related to the material properties. The term “funnel phenomena” comes from the fact that, during extrusion, the material flow is directed towards the center of the billet. If this happens (e.g., with the oxides), the properties of the product are usually not acceptable.

The reason for internal cracking is the inhomogeneous stress distribution inside the extruded material. It can cause defects near the center line of the deformation zone inside the extruded product.

Table 11.1 presents some recommended tolerance values for an extruded profile to ensure its suitability for mechanical microwave components. In practice, the electromagnetic requirements mean that these values are even nine to ten times better than the commonly required values in international standards (e.g., DIN 17615). Usually, so-called high-precision extrusion processes are needed, which are typically applications of cold processing.

In Figure 11.2 there is an example of a typical extruded waveguide profile that can be used, for example, for antenna applications.

11.2 Selected Processes for Shaping Plastics

The most important process types for shaping plastics are extrusion, injection molding, compression molding, thermoforming, casting, cold forming, and processing reinforced plastics. Extrusion of plastics is, in principle, quite similar to the process previously described for metallic profiles. Almost any kind of a cross section is suitable. From the microwave point of view, extrusion is just one way of manufacturing plastic coated electrical wire, cables, and strips. Plastic sheets can also be extruded. Thermoforming is a process

Table 11.1

Recommended Tolerance Values for Extruded Profiles Regarding Microwave Components

Property	Tolerance Value
Dimensional tolerance grade	< IT 8
Straightness (per 1,000 mm)	< 0.2 mm
Flatness of walls	< 0.02 mm
Perpendicularity between the cross section's walls *	< 0.05 mm
Parallelism between the contrary walls *	< 0.01 mm
Minimum radius of the inner corner	< 0.3 mm
Surface roughness R_a	< 0.4 μm
Circularity (if not a squared cross section)	< 0.05 mm

From: [1, 2]

* Depending on the dimensions of the profile

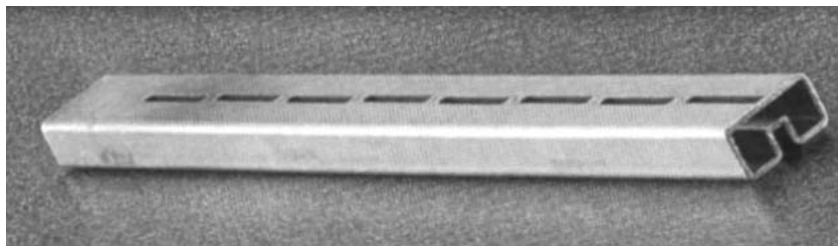

Figure 11.2 An example of an extruded waveguide profile which can be used for antenna applications [3].

used for forming plastic sheets. Front panels of devices could also possibly be thermoformed. During compression molding, an exact amount of material is welled out to the heated mold and the forming is performed by applied pressure. It is widely used for manufacturing several types of electrical components. If the plastic material can be melted into the form of liquid the product can be cast as well. It is usually not known that some plastic materials can also be cold-formed [e.g., acrylonitrile butadiene styrene (ABS) and some polyvinyl chloride (PVC) compositions]. Products made of reinforced plastics (and related material types with some kinds of fibers or various kinds of additional materials) are usually made either by open mold processing (manual method for small series), compression molding (volume production), or winding processes (tubes or similar type of continuous profiles). Examples of the use of reinforced plastics are the radomes for antenna and radar constructions. We have included an example of a typical radome construction on the attached CD-ROM.

11.2.1 Injection Molding

Probably the most important forming technology for plastics is injection molding and its applications. During injection molding, the working cylinder includes the plastic raw material in the form of pellets or granules. This mixture is fed into the heated cylinder, and the melt is forced into a split-die chamber or cavity, usually by a hydraulic or pneumatic plunger or by a reciprocating screw system. Finally, the pressure builds up the product's geometry. In practical work, the pressures usually range from 60 to 210 MPa [4, 5]. Several kinds of products and passive microwave components and devices can be manufactured by injection molding (e.g., housings, knobs, bodies, and fittings). Due to the good formability of the applied materials and the exact dimensions of the mold also the dimensional accuracy of the products

is good. Metallic components, such as screws, pins, and strips, can also be placed in the mold cavity and they become an integral part of the injection-molded product. One application area is again microwave connectors. Although mold design and manufacturing costs are high it is possible to use the same mold several million times (steel molds).

There are some useful derivatives that are developed from the basic injection molding technology:

- Reaction injection molding (different reactive fluids are pushed into mold cavity and the material solidifies due to chemical reaction);
- Injection foam molding (e.g., nitrogen gas is used to expand the material against the mold cavity);
- Blow molding (actually a two-stage process: first extrusion and then injection molding);
- Rotational molding (developed for cylindrical or other solids of revolution).

11.3 Drawing Processes for Wires

During a drawing process, the cross section of a solid rod, wire, or tube is reduced or forced into desired shape by pulling it through a die. Typical semiproducts, for example, are rods and wires. In practice the processes for drawing rods or wires are the same. Drawn wires, however, have much smaller diameters (even 0.01 mm or smaller). In the production of microwave parts, the manufacturing quality of wires is probably the most interesting area. The most important process parameters are the same as in extrusion but of course instead of extrusion speed, for example, we talk about drawing speed. It is interesting to notice, however, that for the drawing of wires for electromagnets, for example, the drawing speed could rise up to 50 m/s. It is easy to understand the relationship between the drawing force, the reduction of the cross section, and the tensile strength of material. If the force exceeds the tensile strength, the wire will break. In many practical tests it has been shown that, ideally, the maximum reduction in cross-sectional area per one drawing stage is 63%. Although wires are here considered as the most important products regarding microwave devices, also various tubes or other cross sections can be made by drawing processes.

For typical wire drawing actions for microwave use, the reduction ratio for one drawing stage is not more than 20% (the use of any larger, such as the

previously mentioned theoretical drawing stage of 63%, would lead to insufficient surface quality and diameter accuracy). To improve surface quality and dimensional accuracy a very light finishing reduction is also often utilized. Some heat treatments (annealing processes) are recommended, especially for copper wires, to ensure homogeneous properties throughout the entire cross section. It is possible to increase the productivity by drawing several thin wires simultaneously in a form of a junction group. Typical errors of drawn products are similar to those found in extrusion. An additional type of defect is the seam, which is a longitudinal scratch in the material.

11.4 Forming Processes for Sheet Metals

There are numerous forming processes for sheet metal work. However, in this content it is reasonable to present briefly only those processes, which have some significant application areas in the field of manufacturing mechanical microwave parts. Sheet metal forming processes can be classified into bending processes (for plates or tubes, stretching), deep drawing process, super-plastic forming and other forming processes (such as explosive or magnetic-pulse forming). Table 11.2 shows a more detailed classification of the processes and some of their foreseen applications for the production of microwave parts or devices.

If any of these sheet metal forming processes is considered as an alternative manufacturing process, it is necessary to remember that in roll forming, each new profile requires new tools and the process is cost-effective only for high volume production. This means that for antenna or radar constructions, for example, there should be opportunities to manufacture at least hundreds or preferably thousands of panels. Stretching is more suitable for limited production series. Tooling costs for drawing and deep drawing are large. The production volume must be more than one thousand workpieces to make the process cost-effective. Also the design costs of the tool are significant. Typically the problems of joining the cover and the bottom of deep drawn enclosures should also be solved before starting the actual volume production. It is also regrettable that most of the specialized sheet metal forming processes (e.g., super-plastic forming, explosive forming) require dedicated equipment and should therefore be used only for strictly limited applications. In many cases, however, either the geometry or required material properties are so exact that hardly any other manufacturing process would be possible.

It is obvious that it is hard or even impossible to draw, bend, or otherwise form exactly sharp-edged corners. This sets a limit for the use of formed

Table 11.2
Applications on Sheet Metal Forming in Microwave Mechanics

Process	Applications in Microwave Device Production
Bending	Wide range of applications from supporting structures to radiating elements of antennas.
Roll forming	Corrugated sheet metal constructions or panels (e.g., for antenna or radar bodies)
Stretching	Sheet metal parts for large antenna elements
Drawing/deep drawing	Housings and enclosures for general electronics and devices
Stamping	IC chip enclosures in which the depth of the cavity is relatively small, (e.g., used for identification numbers on sheet metal surfaces)
Super-plastic forming	Supporting structures for antennas and radars, complicated shapes sandwich body structures (e.g., used in many aerospace applications)

sheet metal products (e.g., for some resonator cavities or waveguides). If formed sheet metal parts are to be included in a microwave device it is important that the designer is able to determine what is the exact amount and size of plate that is needed. The attached CD-ROM illustrates some examples of an antenna construction and associated material calculations. Finally there are three important mainly material related process parameters, which should be taken into account during sheet metal forming: minimum allowed bending radius for the sheet metal material, springback coefficient, and drawability of the material.

11.5 Electroforming Process for Corrugated Waveguides

Probably most readers are familiar with electroless plating, which is based on a chemical reaction without the use of any external electrical supply. The most common applications utilize either nickel or copper. In electroless nickel plating, for example, a metallic salt (here nickel chloride) is reduced, using sodium hypophosphite as the reducing agent, to nickel metal, which then gets deposited on the workpiece. Cavities, recesses, and the inner

surfaces of tubes can be plated successfully. An important variation of electroplating is electroforming, which is actually a metal fabricating process. Metal is electrodeposited on a mold, which is then removed. The “coating” itself becomes the product. Both simple and complex shapes can be produced by electroforming, with wall thicknesses as small as 0.025 mm. Parts may weigh from a few grams to hundreds of kilos. Either metallic (e.g., aluminum) or nonmetallic molds are used. The most important material property of the mold is that it should be easy to remove the mold without damaging the electroformed geometry of the workpiece itself. To make this possible the molds may be manufactured of low-melting alloys, wax, or plastics, which can be melted away, for example. The electroforming process is particularly suitable for low production quantities or intricate parts made of nickel, copper, gold, and silver. It is suitable for aerospace, electronics, and electro-optic components. In microwave mechanics, probably the most important application area is corrugated waveguides. The general advantages of electroforming are very high dimensional accuracy, repeatability of the process, possibility to manufacture weight-saving constructions and good strength of the end product. In many cases electroformed components are real alternatives to conventionally machined components. Sometimes it is even impossible to manufacture selected geometries with traditional technologies (e.g., chases inside a corrugated waveguide if the inner diameter is small enough).

References

- [1] MIFA waveguideshop, “Product Catalogue, Standard Rigid Waveguide and Flange Stock,” <http://www.waveguideshop.com/?openframeset>, Mar. 27, 2002.
- [2] A.T. Wall Company, “Precious Metal Tubin Unit,” <http://www.atwall.com/precious.html>, Mar. 27, 2002.
- [3] MIFA, *Absolute Precision in Aluminium*, Microwave Components Division, Venlo, the Netherlands, 2000.
- [4] Kalpakjian, S., and S. Schmid, *Manufacturing Engineering and Technology*, New Jersey: Prentice-Hall Inc., 2000.
- [5] Wright, P. K., *21st Century Manufacturing*, New Jersey: Prentice-Hall Inc., 2001.

12

Coating

The basic reasons why different, usually metallic, platings are used in many microwave applications are the following:

- Components have a better wear resistance or smaller adhesion—the property of contacting surfaces that is related mostly to the material pair. Some materials tend to stick together easier than the others (e.g., aluminum and steel surfaces get easily stuck due to an adhesive reaction).
- A higher surface hardness is reached.
- It is possible to improve thermal and electrical conductivity.
- It is possible to use cost-effective base materials with appropriate thin coatings.
- Surface oxidation or other unwanted changes during the lifetime of the component can be prevented.
- A better contact between various types of conductors is obtained.
- Solderability of coated strips and wires is enhanced.

12.1 Basics of Coating Technology

Alternative coating processes for mechanical microwave modules include:

- Thermal spraying;
- Vapor deposition;
- Ion implantation;
- Electroplating;
- Electroless plating;
- Electroforming;
- Hot dipping;
- Ceramic coating;
- Organic coating.

In thermal spraying processes, the coating is applied to the metal surface by a spray gun with a stream of oxyfuel flame, electric arc, or plasma arc. The coating material can be some metal alloy, carbide or ceramic, and it can be in the form of wire or powder. Air and oxides can cause porosity to the surface layer, which limits the use of this technology for coating microwave cavities. However, if corrosion resistance is needed this technology is quite acceptable.

Vapor deposition is a process in which the surface is subjected to chemical reactions by gases containing chemical compounds of the depositing material. The coating thickness is a few micrometers. Especially vacuum evaporation has many applications in electronics. The main advantage is the possibility to make a reliable coating also on complicated workpiece geometries. Another application is radio frequency sputtering which is used for manufacturing electrical insulators and semiconductor devices.

In ion implantation ions are focused into the surface of the workpiece. Semiconductors can be manufactured by alloying small amounts of various (material) elements to the surface (usually this technology is called doping).

One of the most important technologies is electroplating in which the workpiece (cathode) is plated with a different metal (anode), while both are suspended in a bath containing a water-based electrolyte liquid. This method is used, for example, for manufacturing copper-plated aluminum wires, electrical components, and for making a specific coating to help soldering. Copper, tin, nickel, and zinc are typical coating materials.

Even more applications than electroplating are found for electroless plating. A chemical reaction is activated without the use of an external source of electricity. Coating thickness remains uniform. It is possible to coat cavities and tubes. Possible coating materials are, for example, nickel, copper,

plastics, and ceramics. The advanced technology called electroforming, developed from electroless plating, is used for waveguides. This is the method used for making gold and silver plating. Typically the layer thickness is 5 to 10 μm [1, 2].

In metal electroless forming (TMF) the component is made from electroless nickel that is subsequently electroless plated with copper or silver.

Hot dipping has several very common applications and it is used for manufacturing galvanized steel structures for long-term corrosion resistance (e.g., for antenna support constructions).

Ceramic and organic coatings can be manufactured, for example, with thermal spraying and are used for improving such properties as electrical resistance, corrosion resistance, and resistance against humidity, aging, and seawater. Many outdoor applications of mechanical microwave devices can make use of a ceramic coating. For electrical insulation, magnesium aluminate and aluminum oxide are used, for example, in the form of ceramic coating.

12.2 Requirements for Coating Quality

In practice, we are probably used to the main idea of utilizing plating so that noble metals are normally applied as thin coating layers on the non-noble base materials. In microwave mechanics this is also one of the guiding principles but also other alternatives should be taken into account depending of the performance requirements of the product.

The quality of the plating process and the surface layer can be estimated with the following characteristics:

- Thickness variation of the coating layer (including inner or outer corners or other difficult geometries);
- Properties of the surface layer under different load cases (e.g., thermal changes, bending moments, chemical loading);
- Surface roughness of the coating layer;
- Hardness profile variation of the coating layer.

12.3 Coating Materials for Microwave Mechanics

The most used coating materials in mechanical microwave devices or components are gold, silver, nickel and tin-lead-alloys. Also copper, palladium, and white bronze are utilized like in general electronics. However, usually the comparison or choice is made between gold and silver.

Gold

In practical applications gold is usually alloyed to give it more strength. Gold is a good conductor of heat and electricity and unaffected by air and most chemicals. It is an excellent material for electrical signal transmission. Machinability of gold is relatively good. Gold can be deposited on nickel or copper. Nickel is often deposited as under-plating to gold, because gold is quite expensive compared to other plating materials. Also to avoid diffusion, nickel is used as under-plating of the gold layer. One common application where gold plating is used is coaxial connectors, for example, SMA connector center pins. In printed circuit board applications nickel under-plated gold legs of the components provide a good solderability. Gold plated material itself has poor wear properties. If gold plated pins are used in connectors, for example, it is important to regularly follow the quality of the layer to prevent the problems of possible wear-through.

Silver

Silver is typically used in RF and microwave devices and components for making soldered and brazed contacts. Silver has best conductivity of all metals, which means that it can carry a high current load with the least loss at the highest microwave frequencies. This property is important, for example, if very low levels of passive intermodulation are desired. It means that unwanted mixing products (basically of the same type as those wanted signals observed in common RF mixers, but appearing just due to a nonlinear, bad galvanic contact) can be prevented in a silver junction into which two or more high power signals are injected. The most regrettable property of silver is its propensity to create an oxide film on the product's surface if the environment exposes the surface to ozone, hydrogen sulphide, or sulphur. To avoid, or at least slow this phenomenon, passivation should be done for silver coatings.

In its traditional meaning, passivation has been used to describe the phenomenon during which a passive film (such as oxide) is formed on the material's surface. This film protects the base material for environmental loading. In cases where this kind of layer is unwanted, however, the term "passivation" is nowadays used also to show how to prevent the surface from reacting with the environment. This is what we are discussing here in the first place regarding silver coatings.

The oxygen and the sulphide gases readily combine with silver to form oxides and sulphides. Prevention in manufacture consists of using silver alloys that are designed with resistance to oxidation and involve the use of special additives such as silicon or germanium. This works well if all manufacturing

factors are properly controlled, including using 100% new metal each time when casting, accurate temperature control in melting and annealing, and no metal mixing using silver from different sources. Electroplating with 100% silver will also reduce the rate of oxidation. Rhodium can also be used but the cost is usually relatively high.

For post manufacture prevention of oxidation there are three basic systems, which are polymer/ lacquer coatings, immersion processes and electrolytic treatments. Lacquer/polymer systems are really different methods but both seal the surface of the silver to exclude gasses in the atmosphere. The advantage is that they are very strong and effective. The disadvantage is that they need very technically competent control. The set up is also very expensive and the treated parts are not practical for machine elements for mechanisms. Immersion dip treatments consist of using various proprietary solutions and they are quite good at removing oxidation but the protective surface produced is fragile and unstable. Dipping in chromate-based chemicals works but is very fragile and will not even resist normal handling. Electrolytic passivation of the surface seems to be the most promising and most practical option for silver coated surfaces. The process creates a passive surface that resists oxygen and sulphides by creating a barrier, rather like the anodizing of aluminum. The basic system uses the fitted stainless steel electrodes that cause an invisible protective film to build up on the surface of silver or silver plated component, rendering the surface impervious to oxidation gases.

In cases where the term “passivation” is used to emphasis the importance of forming the protective layer on silver the environmental loading is especially difficult. There are several ways to form a protective layer for these kinds of load cases. Tin chloride treatment can used on top of the silver layer as a protector against corrosion because silver forms easily the intermetallic, Ag_3Sn composition. This alloy can be formed either by electroplating or by pulse plating, and has been used traditionally to protect silver. If immersion tin is taken to completion it should be heat treated in an oven at 130 to 180°C for 10 to 20 minutes. Passivation of silver is not easily achieved, but a thin copper layer has been used for this purpose. The silver layer can be protected also by a passivation layer of a nickel and/or chromium alloy or nitride and by one or more durability layers made of metal oxides and typically a first layer of metal nitride. The durability layers may include a composite silicon aluminum nitride and an oxinitride transition layer to improve bonding between nitride and oxide layers [3].

In a great deal of research, silver surfaces have been exposed to silicongstic acid. During this process monolayer-thick arrays of silicotungstate

ions form spontaneously on silver surfaces, providing an adherent, passivating oxide coating on the metal surface [4].

Nickel

Nickel is used for plating connector or component bodies, for example. The most important application is, however, the use as an under-plating material for gold. Nickel's high permeability limits the use in applications where magnetic materials are not acceptable. The serious problem of a nickel surface layer is the risk of flaking (e.g., due to mechanical overloading). This will immediately destroy the otherwise relatively good protective surface. In addition, one common disadvantage is the possibility of an allergic reaction to nickel—not a diminutive risk if continuously working with connectors.

Tin-Lead Alloy

In practice, tin-lead alloys are used to improve the solderability properties of the construction or component. It is also sometimes used to coat copper in order to improve corrosive resistance.

SUCOPLATE® (Copper-Tin-Zinc Alloy)

SUCOPLATE was developed by the Swiss company SUHNER for the purpose of supplying a plating which could resist oxidation and ensure a strong nonabrasive yet attractive surface for a reasonable price.

The plating material is a copper alloy composed of the three components: Copper, tin, and zinc. Being nonmagnetic and nonallergic (nickel free), it is an alternative for nickel plating, which generally has a lower electrical performance and lower corrosion resistance. The nonmagnetic property in the contact area is also important for obtaining negligible passive intermodulation products (PIM) in communication systems, such as base transceiver stations of mobile networks.

Outer conductors leave a hard and abrasion-resistant surface allowing more than thousand matings before the material is worn away. Usually, the outer conductors have silver plating under a SUCOPLATE flash. The silver with its high conductivity is able to carry most of the transmitted signal in the outermost surface of the conductor, as the frequency increases. For outdoor use corrosion resistance is good.

SUCOPLATE can be direct-contacted with nickel, silver, and copper alloy base materials, without exceeding the maximum electrochemical potential of 250 mV. Furthermore, it has a consistent plating thickness distribution from the electrolysis process. In addition, it is a good substitute for silver plating, as it is less expensive than silver [5].

Some practical applications are hampered by problems when trying to assemble constructions having both Sucoplate and other connectors. It seems obvious that the surface might show an adhesive reaction pair with some of the common materials used in mechanical microwave devices.

To ensure the right properties of the coating of the base material it is extremely important to find the best application of each plating technology and alternative plating compositions. There are more than ten types of gold plating, for example. Table 12.1 presents the most frequently used plating types of gold.

There are specific plating types of each coating material, which are suitable for microwave applications. These types are presented in Table 12.2.

For practical plating applications it is important to fit together the mechanical properties of the plating material and the base material. If any mechanical loading can be expected, the differences between the values of modulus of elasticity are in key role. Let us consider the case where we are plating a strip with a metallic coating. If the base material is relatively stiff compared to the coating layer there are usually no problems. If the coating layer is stiffer than the base material (the strip itself) there is a possibility that the thin coating layer can break due to bending stresses of the construction. To avoid this, it is not possible to change the material properties but we can change the cross-sectional geometry of the strip to make it stiffer. Exactly the same problem will arise if there are large differences between the values of thermal conductivity and thermal expansion coefficients of the coating layer and the base material. If we can assume that the coating layer won't lose its

Table 12.1
Plating Types of Gold

Plating Material	Plating Type
Gold	Cyanide based, neutral pH, no additive Cyanide based, neutral pH, arsenic additive Sulphite gold Immersion, sulphite based, solderable on electroless nickel Electroless, sulphite based, wire bondable Cyanide based, cobalt brightened Cyanide based, nickel brightened Cyanide based, Co-Ni-In-Zn-Fe-Cu-Ag brightened Cyanide based, neutral pH, arsenic additive Sulphite based, ammonium

Table 12.2
Suitable Coating Types for Microwave Constructions

Plating Material	Plating Type	Application Area
Gold	Cyanide based, neutral pH, arsenic additive	Generally in microwave mechanics
	Cyanide based, immersion	Printed circuit boards
	Sulphite gold	Thin film circuits
	Cyanide based, cobalt brightened	Connectors
Silver	Cyanide based, organically brightened	Microwave boxes
	Cyanide based, Selenium brightened	Generally in microwave mechanics, connectors
Palladium	Nonammonium, Nonchloride	Connectors
	Nitride based	General electronics
Copper	Acid based	Connectors
	Cyanide based, bright	General electronic components and aluminum boxes
Tin lead	Bright	Connectors
Tin copper		
Nickel	Sulphate based, NiP alloy	Connectors
Rhodium	Sulphate based	General electronics
Bronze	White bronze	Electronic components

contact with the strip, the different thermal expansions will cause bending moments in the strip, and further on they will cause an unwanted twisting of the strip. These problems can be avoided by using proper cooling systems or by optimizing the cross section of the strip. For practical design work, we have collected some values of modulus of elasticity and thermal conductivity for the most common constructive materials to Table 12.3.

12.4 Case Examples of Coated Microwave Components

Leads, Terminations, or Contacts

Tinned or gold plated leads, terminations or contacts are used in many types of applications, such as oscillators, mixers, switches, stripline assemblies, filters, frequency multipliers, and bias networks. There are two main reasons to guide the material selection of plating: first electric conductivity and

Table 12.3

Values of Modulus of Elasticity, Thermal Conductivity, and Thermal Expansion Coefficient

Material	Elastic Modulus [Pa]	Thermal Conductivity [W/m°C]	Thermal Expansion Coefficient [$\mu\text{m}/\text{m}^\circ\text{C}$]
Aluminum 6061-T6	7.310E+10	155.80	24.30
Aluminum 7079-T6	7.172E+10	121.10	—
Beryllium QMV	2.897E+11	147.10	14.94
Copper—pure	1.172E+11	392.90	16.56
Gold—pure	7.448E+10	297.70	4.39
Nickel—pure	2.207E+11	91.73	12.96
Silver—pure	7.241E+10	417.10	19.80
Steel AISI 304	1.931E+11	—	17.82
Steel AISI C1020	2.034E+11	—	11.34

secondly solderability. Many components (e.g., RF capacitors) are usually supplied with standard tin plated over nickel-barrier terminations making them ideally suited to repeated soldering and desoldering operations.

Circuit Boards

Another important application are of various plating technologies is the manufacturing of circuit boards and housings within the microwave industry. In cases where precision plating is necessary, such technologies as atomic absorption and X-ray fluorescence technology can be utilized to ensure the quality requirements. The most used plating materials in this case are:

- Copper;
- Tin;
- Tin/lead;
- Gold;
- Electroless nickel;
- Sulfamate nickel;
- Iridite coating;
- Chromate coatings.

Gold plated bellows contact springs can be used to provide electrical continuity on those printed circuit parts, where tolerances build up or vibration and thermal expansion need to be overcome. These bellows contacts are manufactured from electrodeposited nickel and later gold plated to enhance their conductivity. They are designed to be both flexible and dynamic and to provide a lifetime of reliable interconnection.

Waveguides

The inside surfaces of waveguides are often plated to reduce skin effect losses, but this increases costs. Many types of rectangular or double-ridge flexible waveguides can be constructed of silver plated copper alloy. The tube is manufactured by using hydraulic precision forming. Flexible waveguides can also be manufactured from aluminum alloys with various flange configurations. The waveguides may also be plated in accordance with a customer's requirements. Some alternatives for silver plating are finishes with gold, copper, or aluminum iridite. Silver plated or chromated coating schemes are typically manufactured with options for flexible sections and thermal control. Exterior protective coatings include molded neoprene, plastics and various paints and enamels.

Waveguide Bandpass Filters

In principle, waveguide bandpass filters consist of half wavelength resonant cavities coupled by capacitive or inductive irises. These extremely high Q structures provide very low passband loss and steep attenuation skirts. Depending upon the bandwidth, either inductive irises or inductive posts are used to control the coupling between each cavity. By using several adjacent high and low impedance sections, a corrugated waveguide lowpass filter can be designed to have a wide passband and a wide bandstop for power in the TE_{10} mode. Base material and its plating selection for a waveguide filter depends upon the specific requirements. Copper is generally used, but for wide temperature ranges and narrowband applications invar is used to guarantee frequency stability. Aluminum can also be used for lightweight applications. In many cases waveguide filters are silver plated to minimize the insertion loss.

Waveguide Valves

For a better RF-transmission in many applications of waveguide valves and their flanges, the base material is stainless steel but the inner walls are plated with copper.

Cavity Filters

In general, cavity filters offer the user very low insertion loss, steep skirt selectivity, and narrower bandwidths than discrete component filters. Cavity filter performance is based on parts selection and physical layout of the helical coils, resonators, as well as the shape and size of the cavity housing. Standard cavity filters are generally designed using aluminum as the base metal. As most raw metals are inherently lossy, filter housings are silver plated for improved electrical characteristics and current flow. Brass, copper, aluminum, or bimetal resonators are used to minimize frequency drift over temperature.

High Power T-Switch for S-band Space Applications

Reliability and high-performance levels are two basic requirements of any component designed for a satellite or the space shuttle. One case example is a S-band electromechanical T-Switch designed for space-based transmit applications, which must operate when needed over the life of the satellite. The T-Switch is housed in an aluminum enclosure. The RF cavity is also aluminum with gold plating to enhance conductivity and minimize signal loss. The connector shell is gold plated.

Rotary Joints

Material requirements for rotary joints, which are used, for example, in radar antennas, surface-to-air missile applications, and onboard military aircraft, are very specialized. A number of coupling techniques can be used in the design of coaxial rotary joints. The most common and versatile technique is one in which the rotating surfaces of the conductors are directly contacting. In this design, one contacting surface is made of coin silver, the other is made of silver-impregnated graphite. The contact junctions are spring loaded to ensure continuous contact, thereby providing both an excellent low loss transmission line as well as a low friction mechanical bearing. This type of junction operates from DC to very high microwave frequencies, being limited only by the connectors and the coaxial dimensions of the coupling structure [6]. Typical base materials and their platings of the construction are:

- Chrome-plated brass body;
- Beryllium copper connector contacts;
- Noble metal inner and outer contact junctions;
- All metals except contact-junctions appropriately plated to inhibit corrosion in accordance with all military specifications;
- Mounting nuts and screws of cadmium plated brass.

Antenna Applications

To withstand the environmental loading (for example corrosion) the most typically used construction materials and their coatings are:

- Plated or stamped aluminum;
- Hot dipped galvanized steel;
- Stainless steel.

References

- [1] Kalpakjian, S., and S. Schmid, *Manufacturing Engineering and Technology*, New Jersey: Prentice-Hall Inc., 2000.
- [2] Wright, P. K., *21st Century Manufacturing*, New Jersey: Prentice-Hall Inc., 2001.
- [3] Wolfe, J. D., and N. L. Thomas, "Durable Silver Coating for Mirrors," U.S. Patent 6,078,425 June 20, 2000, <http://www.llnl.gov/str/March01/PatMar01.html>, Feb. 25, 2002.
- [4] Klemperer, W. G., "Current Research," <http://www.scs.uiuc.edu/chem/gklem2.html>, Feb. 25, 2002.
- [5] *Suhner RF Connector Guide*, Switzerland: Huber and Suhner AG, 1997.
- [6] Sivers Lab A (Chelton Group Company), *Rotary Joints and Switches, High Precision Mechanical Microwave Products*, Upsala, Sweden: Wicström, 2001

Part 3

Examples of Requirements for Mechanical Accessories in Microwave Assemblies

13

A Microwave Measuring System for Wood Quality

This chapter includes many examples of practical mechanical arrangements necessary in a microwave system. Our intention is to highlight some of the previously described manufacturing technologies in light of their RF applications, and at the same time give the readers an idea of the multitude and complexity of the problems involved in a real case project. As will be seen, sometimes just one threaded junction may be the cornerstone for the performance of an entire device. Besides this, several microwave systems make extensive use of mechanisms in order to establish the desired mutual movements and functions. Such dedicated parts require special attention and careful design practices. Although much of the work described here was originally targeted towards a microwave measuring system, the applied design rules are suitable for a large variety of tasks.

Typical parameters which influence the value of a log and its use include, besides the dimensions, the number of knots per volume, the density or mechanical strength, and the annoying internal bends, or skewness. Bad internal deteriorations can be classified as plant diseases or as insect holes both of which completely spoil at least a portion of a log. Many of these cannot be figured out by conventional external inspection—not at least fast enough in order to be efficient in terms of current modern forest utilization. Initial attempts have been made to use X-rays for the analysis, but putting such a device in a highly mobile harvester system, for example, is quite

impossible. Microwave techniques were also tried in the late 1970s and early 1980s but these projects were not commercially successful due to the seemingly too costly electronics at that time.

In [1], the system was not based on pure microwave radiation, but required a supplementing gamma source and an infrared detector, too. The somewhat complicated yet not-far-from-mature system was only applicable in a steady saw-plant type installation. The method in [2] was also targeted to sawn goods and utilizes a special polarization arrangement for knot detection only. Its geometry was quite easily handled due to the square cross section of the assumed samples. The theoretical base was presumably founded in [3] during the 1960s. Further, more practical approaches for a narrow application area are demonstrated, for example, in [4, 5], but these two are focused at industrially produced materials like relatively thin veneer or particle board and were targeted towards a factory-floor environment. On the contrary, circumstances and usage described for example in [6] are to be anticipated if the instrumentation is mounted on a harvester system. The physical size, weight, and shape of the samples are challenging and the dynamic variations in, for example, humidity or temperature must be considered as exhaustive.

13.1 Description of the Test Arrangement

Initially, the idea was tested in a narrowband fashion with commercially available laboratory instruments and off-the-shelf waveguide adapters in [7]. Wood material is basically a lossy nonhomogenous dielectric at microwave frequencies. Suitable indirect test parameters include attenuation, phase shift and reflections at the material boundaries, which all guide us towards the complex permittivity. Also the changes in the polarization level are suitable as indicators. However, a VNA is too precious a device to be taken into the forest. Besides, its +10-dBm source power is far too small for thick logs and the conventional frequency sweep too slow for an efficient harvester. Something more robust was to be at hand, without losing the solid background.

The full, technically available, and economically feasible frequency range should also be considered. The prototype system basically measures the microwave transmission and reflection observable in a growing tree before it is cut or in a complete log just after cutting prior to sorting for the coming use. Two sets of small specially configured transducers are connected electrically to the TR-test device currently operating both in S or K-band. The complex S_{12} is measured as a function of distance along the tree. An option exists for the simultaneous recording of S_{11} as well, which can help in

separating less important fluctuations caused by the very rough surface (e.g., of old pines) from the actual interesting internal deformations. A generalized block diagram of the prototype design, in principle valid for both frequency bands, is shown in Figure 13.1. If the polarization plane is turned or swept or the sample is rotated, the skewness and bends of the structure will come out. However, it is to be noted that in our scheme, the polarization performance is not a key feature of the transducer arrangement, which was the case in [2].

Key performance figures of the prototype include one TR-set per frequency band moving along the log's growing direction (log being rotated as necessary), built-in microwave source, receiver and detection modules and filtered outputs of transmission parameters suitable for typical PC data acquisition cards. The operating principle relies on the comparison of two signal paths containing the same frequency. The reference and test signals are downconverted to 600 MHz where the phase detector operates. Two local oscillators, marked as LO in the block diagram, have been included. The one operating at 14.7 GHz supplies the signal, which goes through the wood material. The second oscillator is an auxiliary device. Selective measurements are a lot easier with the adopted superheterodyne principle.

Microwave power is obtained through a chain of a dielectric resonator oscillator, one power divider, a combline filter and a power amplifier stage

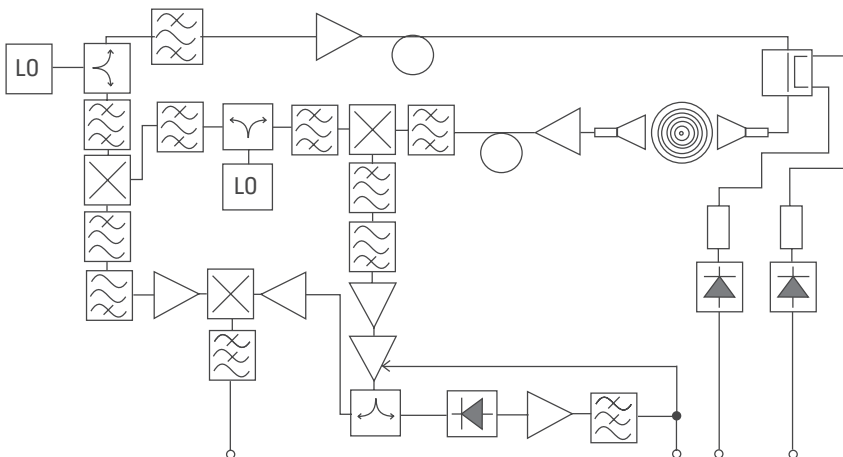

Figure 13.1 Theoretically, the properties of wood (or any other dielectric obstacle) could be studied with a vector network analyzer, which is used to record the four scattering parameters (S_{11} , S_{12} , S_{21} and S_{22}) as a function of frequency and location. A heterodyne receiving scheme is used to convert the Ku- or S- band microwave signal into phase and amplitude information.

made of commercial MMIC chips. The power injected to the log is about +30 dBm and the frequency stability is better than 100 kHz. This arrangement is cheaper than a synthesizer, and we get a far better spectral purity close to the carrier. No cables have been used in order to get the largest possible output power and to avoid any leaking interference, which could be a problem in a flexible coax. An additional benefit is the phase stability, which is guaranteed by the mechanically rigid assembly. The only unavoidable cables are those just next to the adjustable transducers where no other practical alternative was available.

Similar arrangements are applied on the receiving side of the system. A typical attenuation in a fresh tree for a wave polarized perpendicular to the growing direction is more than 160 dB/m and thus the receiver noise figure must be kept near 1 dB but unfortunately the front-end bandwidth can not be reduced accordingly. After the transducer and the special microwave cable we see a low noise amplifier (LNA), which has a noise figure of 1 dB and a gain near 20 dB. A cascaded low pass–high pass combination is used to form the necessary 600-MHz IF filter. Both of them are of milled coaxial design and apply the principle of successive high and low impedance sections. Their measured frequency responses are illustrated in Figure 13.2.

A two-way directional coupler has been added to the transmitting side to give a possibility for an S_{11} measurement. Its coupling is 20 dB, which yields, after 10-dB attenuators, a suitable power level for a direct diode detection. Attenuators are also necessary in providing a reasonable return loss for the coupler output.

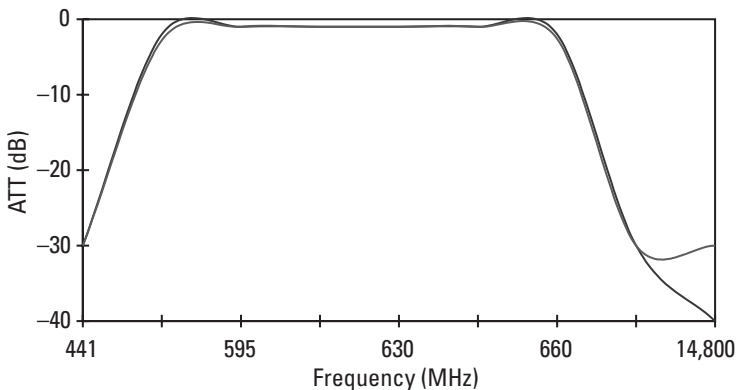

Figure 13.2 The measured frequency response of the milled coaxial intermediate frequency filters. Note the nonlinear frequency scaling in which the stopband from 660 Hz to 14,800 MHz is just for information only.

The group delay measurement is even more difficult because it requires a stable reference power level and the automatic gain control (AGC) attack time should be at least an order of magnitude shorter than the smallest impulse caused by an interesting change in the woods internal structure. The maximum log sample diameter successfully tested is 500 mm (a freshly cut fir log) where the smallest detected internal discontinuity was 3 mm. The typical spatial resolution is now better than 10 mm along the log's growing direction with an optimum measuring speed of 0.1 to 1 m/s. A typical test set-up is illustrated in Figure 13.3. As a supplement to the K-band electronics we introduced the S-band averaging device. This transceiver utilizes a pair of slotted waveguide antenna arrays as transducers. A more comprehensive and detailed description of the various applications possible with the constructed prototype can be found, for example, in [8] and [9].

13.2 Transducer Arrangements

Both pyramidal horn antennas and simple rectangular waveguides have been successfully tested as transducers. They are designed to operate using the TE_{10} mode. At 15 GHz the measured gain of the horn is 19 dBi and it gives a

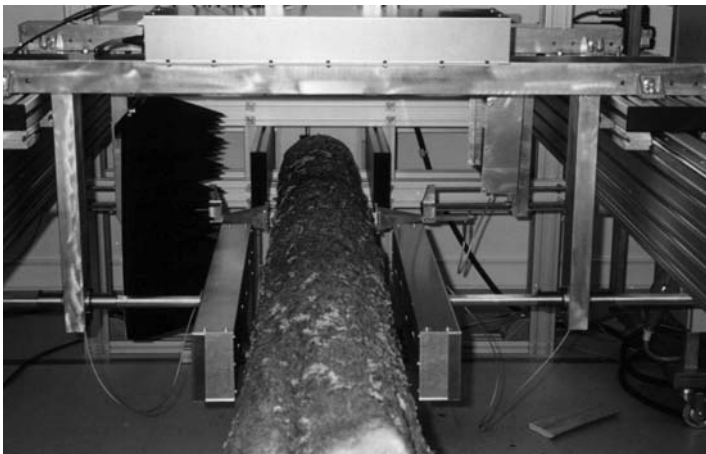

Figure 13.3 The transducers, receivers, and the housing of the electronics are assembled on two sequentially welded aluminum bars. The Ku-band transducers are facing each other across the log with absorbing material surrounding the receiving side. The detailed manufacturing drawings are presented on the attached CD for all these mechanical supporting elements.

better sensitivity for wet wood at the expense of spatial resolution whereas the simple waveguide end can detect discontinuities down to about 10 mm along the direction of movement. As illustrated in Figure 13.4, the measured 3-dB beam width is about 40° but this is not the actual measuring window due to the apparent near field effect. Side lobes are hard to avoid in the vertical plane if we don't apply a corrugated design to mimic a perfect magnetic conductor. The drawbacks of such a construction are its relatively high manufacturing cost and the narrow bandwidth.

A low back lobe level is very attractive for this purpose. The horn gives at least 35 dB of attenuation in its rear sector and we can thus avoid most of the reflections from the supporting structures. Both antennas need microwave absorbers in their front sectors as illustrated in Figure 13.3. In our case the pyramids are 200 mm high and the antennas have a small rectangular hole to "look through." Their effective attenuation against reflections is about 40 dB at 15 GHz or their RCS about 40 dB lower than that of a perfectly conducting plate.

Much attention was given to the impedance matching of all the transducers. This was necessary to get the best possible sensitivity but also to avoid the destruction of power MMICs due to excessive reflections. After careful adjustments the results indicated in Figure 13.4 were achieved. The optimum matching is available near the operating frequency (14.688 GHz) and

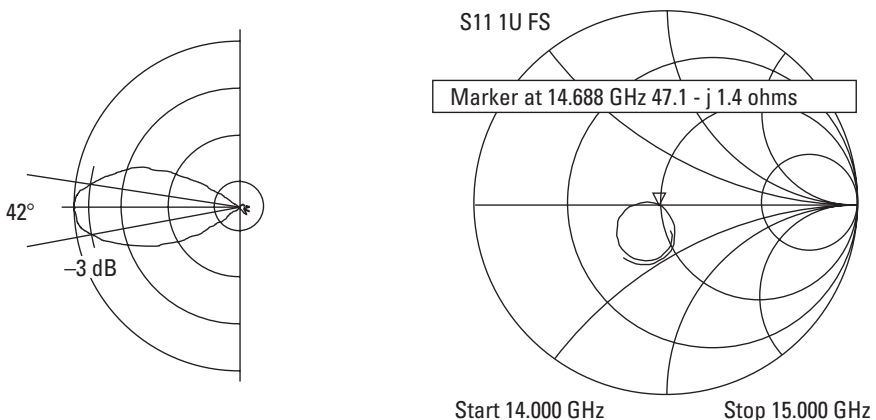

Figure 13.4 The measured azimuth pattern of the horn antenna is presented here. The back lobe is about 35 dB down and side lobes don't show at all. The measured input impedance of the pyramidal antenna is presented on the right, using relative scaling only. Thus no absolute values are given on the axes. A good matching is required for best sensitivity and power amplifier safety.

the respective return loss is about 30 dB. This is impaired by 1 to 2 dB because we need a Duroid radome in front of the horns but still this value is very satisfactory.

The S-band transducers are actually two linear slot antenna arrays machined on the surface of 120-mm \times 60-mm aluminum waveguide. They are matched with a sliding short, which is mounted on the guide end and by fine tuning the feed probe length. Because the wavelength is here about 0.17m, the real gain is of minor importance.

13.3 Mechanical Requirements for the Measurement System Assembly

The wood quality measurement system is assembled on an aluminum framework. This quite huge metal profile construction is presented with photos and 3-D models on the attached CD-ROM. The main requirements for this structure are as follows:

- The structure should be rigid to ensure a precise positioning of the transducers.
- The electric drive, utilizing a cogged belt system, should be accurate enough to ensure the required horizontal stability of the transducer velocity.
- The body should be able to damp any vibrations due to start/stop actions or during the drive (actually, the supporting system against the floor and the mass-damping properties of the frame are in key roles).
- Two guide bars on both sides of the frame should meet the geometrical tolerances to ensure that the transducers can be kept exactly aligned with each other
- The amount of metal should be kept small around the measurement system itself to avoid unnecessary reflections.

The transducers, receivers, and the housing of the electronics are assembled on two sequentially welded aluminum bar constructions. The bars (one horizontal and two perpendicular bars against this) have to be relatively rigid, because they have to withstand all the mechanical loading. They also work as protective shells for the cables. Because the guides of both transducer types are further supported to these welded constructions it is necessary that

the bars exactly fill the required manufacturing tolerances. The detailed manufacturing instructions are presented with full tolerance identifications on the attached CD.

Both the horn and slot antennas are supported with special guiding constructions to the welded bars. The horn antennas need a system, which consists of three threaded rods that are positioned at the corners of a triangular cross section. The mass of the horn antenna is so small that if the bending moment would have been the only load to be handled, the horn could have been supported with one or two rods only. However, the third rod is necessary to ensure the right position also around the horizontal axis through the antenna (torsional positioning). The rods are mounted inside precision machined steel collars. They make it easy to correct possible manufacturing errors due to welding because the collars are first mounted in the desired position inside the welded vertical bars. These collars also work like sliding bearings for the rods. It would have been impossible to make guiding holes directly on to the aluminum profile, because the softness of this material would have led into rapid wear of the holes. This construction is presented in Figure 13.5. To minimize the amount of metallic material behind the slot antenna only one rod is used. One segment of the circular cross section of the rod is machined as a plane against which the rotational positioning of the rod can be locked whereby we can set the wanted wave polarization. The rod moves inside sliding steel collars, which also include the lock screws (see Figure 13.5).

To connect the antennas to the guiding rods some special arrangements are needed. With horn antennas a milled component is manufactured (see Figure 13.5). The face against the opposite horn must be chamfered to reduce the level of reflections. The slot antenna is actually manufactured from a right-angled parallelogram aluminum profile. It is then placed inside a sheet metal housing, which is further joined with the guiding rod. To make this joint, some specialized arrangements were needed to ensure the rigidity of the sheet metal part. The dimensional details are presented in the drawings, which are on the attached CD.

Although the components needed for the mechanical assembly seem to be relatively simple sheet metal parts, machined components or welded bar constructions, their price is much higher than could be expected. The manufacturing accuracy requirements are in most of cases much tighter than in general engineering and the requirements to ensure the wanted microwave performance make it impossible to construct the most reasonable supporting systems in a sense of mechanical engineering. In general, in this application the tolerance grade IT5 was required in sliding systems and IT6 for any other parts of the construction.

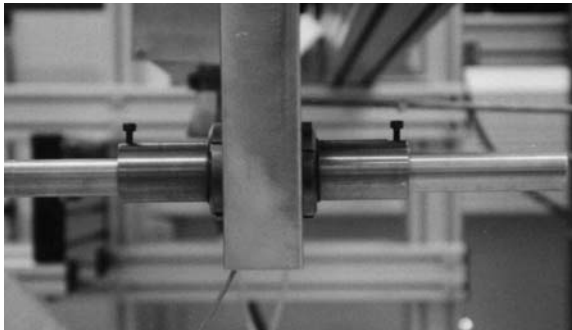

Figure 13.5 The supporting rods for the horn antennas are presented on the top. The third rod is needed for the rotational positioning (polarization). Notice the sliding steel elements, which are assembled through the vertical bar. Also the fixturing device for the horns is a precision machined component. Sliding element for the slot antennas are presented on the bottom. The rotational positioning (polarization) can be locked with adjusting screws (both photos are zoomed from Figure 13.3).

13.3.1 Serviceability and Easy Access

A quite regrettable fact is that in many mechanical microwave devices the aspects of serviceability or easy access cannot be followed thoroughly. Also the questions of cost-effectiveness and handling comfort are contradictory because cheap sheet metal enclosures, which are typical for prototypes, are at the same time cumbersome but might need to be opened frequently just due

to the prototype nature of the device! In this special application, some electrical devices were assembled, for example, inside the vertical bars to minimize their distance from the antennas. It is easy to understand that both the assembly and later service of these assemblies are difficult. Also the application of sheet metal boxes for electronics makes it necessary to use a relatively large number of screws to prevent noise due to otherwise improper shielding properties. Of course it can seem frustrating to open and tighten these screws before and after each service operation. Also the use of absorber material can cause difficulties for easy access (see Figure 13.3). However, for performance-oriented design the minimum requirement is that at least the most nearby area around the transducers is covered with appropriate absorbing material.

References

- [1] Tiuri, M., K. Jokela, and S. Heikkilä, "Microwave Instrument for Accurate Moisture and Density Measurement of Timber," *Journal of Microwave Power*, Vol. 15 No. 4, 1978, pp. 26–32.
- [2] Jakkula, P., *Method and Apparatus for Detection of Knots or the Like in Sawed Lumber*, U. S. Patent 4607212.
- [3] Tinga, W., "Dielectric Properties of Douglas Fir at 2.45 GHz," *Journal of Microwave Power*, Vol. 4, No. 3, 1969, p. 162.
- [4] Vainikainen, P., E. Nyfors, and T. Fischer, "Radiowave Sensor for Measuring the Properties of Dielectric Sheets: Application to Veneer Moisture Content and Mass per Unit Area Measurement," *IEEE Trans. on Inst. and Meas.*, Vol. IM-36, No. 4, Dec. 1987, pp. 1036–1039.
- [5] Vainikainen, P., and E. Nyfors, "Sensor for Measuring the Mass per Unit Area of a Dielectric Layer," *Proc. 14th European Microwave Conference*, 1984, pp. 667–672.
- [6] Eskelinen, H., and P. Eskelinen, "Observations on the Manufacturability of Mechanical Subassemblies for Remote Sensing Transducers," *Proc. URSI/IEEE XXIII Convention on Radio Science*, Helsinki, Finland, 1998, pp. 167–168.
- [7] Eskelinen, P., and P. Harju, "Characterizing Wood by Microwaves," *IEEE Aerospace and Electronics Systems Magazine*, Vol. 12, No. 2, 1998, pp. 34–35.
- [8] Eskelinen, P., and H. Eskelinen, "A K-Band Measuring System for the Analysis of Tree Stems," *Silva Fennica*, Vol. 34, No. 1, 2000, pp. 37–45.
- [9] Eskelinen P., et al., "A Microwave System for The Analysis of Trees and Logs," *Proc. MIOP 2001*, Stuttgart, Germany, 2001, pp. 182–185.

14

Antenna Constructions

One of the “all-analog” radio elements is the antenna set-up. Although mobile handsets use circuit board patch antennas, most of the base station hardware and almost all broadcasting and radar antennas are mechanical designs made of metal pieces and sheets. The one thing that most antennas have in common also makes the largest notable difference between them. An antenna has to be somehow comparable in its physical size to the operating wavelength. Thus, the smallest microwave antennas are fractions of a centimeter, whereas the largest ones exceed one meter.

The main function of an antenna is to be the interface between a propagating wave and the transmission line world. Typically, an antenna has a supporting and mounting structure, a cable, or some kind of a panel-type connector, and naturally the radiating element or elements. Some antennas have a reflecting surface, which is fed by a small element in front of it or alternatively a considerable number of elements can be assembled as an array. These specific structures include power dividers and phase shifting networks.

This chapter is not a comprehensive discussion of antenna engineering practices and principles but more an introduction to the various problems related to the adverse operating environment in which practical antennas are supposed to work. The reader is encouraged to refer to, for example, [1] or [2] for more information on the electrical dimensioning rules and design tricks. Additional details on antenna fabrication and several illustrations of antenna configurations are available in the attached CD-ROM.

14.1 Basis for the Design of Antenna Constructions

Almost all practical antennas can be designed from computer simulation results. Various electromagnetic software packages are available for such tasks but very few of them support any data transfer to mechanical drawing environments. Special care is needed if the antenna under construction is very large compared to the system wavelength because many simulation tools have to use simplifications to reduce memory consumption. After these “streamlining” actions, the simulation results may no more correspond to the real world situation. Topics to be comprehensively discussed during an antenna design process include the radiation pattern (beam width, side lobe level, front/back-ratio), gain (including losses), polarization (also a function of frequency) and impedance across the entire operating frequency range. Also weight (due to mast loading), physical dimensions (because of array assembly restrictions), ice and wind loads, and corrosion have to be taken into account.

Severe operating environments or dedicated antenna components require the use of a protective radome, which must not disturb the designed impedance or radiation characteristics. Antennas operating at lower microwave frequencies accept a thin reinforced glass fiber sheet in front of them, but those above 10 GHz need, for example, Teflon-based solutions. A well-designed aerodynamical radome also reduces wind loads.

Typical antenna constructions can be classified, for example, as monopoles, dipoles, horn antennas, reflector antennas, or patch antennas. Monopoles and dipoles are often made of metallic tubes, which need not be particularly complex but do not have a very high gain either. The practical frequency range is from some tens of megahertz to about 2 to 3 GHz. Horns are made of sheet metal or, occasionally, milled. They are not very practical below 1 GHz, due to the huge size. At higher microwave frequencies (up to 300 GHz and more) their gain is 15 to 25 dBi and the side lobe levels are reasonable. Horns are also needed in reflector antennas as feeds.

Reflector antennas are often called parabolic, because of their simplest representative. Most often they have a feed horn either at the focal point or alternatively in an offset position. Also, cassegrain antennas are used where an additional subreflector is needed. The metal surface can be anything between a couple of centimeters and about 100m. The reflector is often made of sheet aluminum. Its key characteristics are surface quality and shape fidelity, which must be maintained through the temperature range and physical alignment.

Patch antennas are an interesting alternative for dipole arrays because of the relatively cheap planar construction. They can be assembled from

sheet metal elements or on a printed circuit board. The dielectric material seriously limits the impedance bandwidth, but a sheet metal design can use the best possible choice—air. A single patch element has a gain near that of a dipole but its radiation pattern is often a bit asymmetric.

14.2 Wind and Ice Loads

The mast or tower and all the mounted antennas should be considered and designed as a mechanical entity. This means that the required rigidity of the mast depends mostly on the wind pressure area of the mast and the assembled antennas. The dimensions of the bars and the frame will be designed for a specified wind load. This further affects the mechanical support construction of the mast base and the possible need of guys. On the other hand, the mast's ability to prevent ice from forming is important for keeping the wind pressure area low. The antennas and the associated fastening hardware, however, tend to form hollows or cavities into which snow and ice accumulate.

Smart antennas may require that some electronics is near the radiating elements. This can lead temperature changes during use. If the air humidity and temperature are critical frost might be formed on the antenna surface. This can initiate ice-forming. If there is enough ice it can lead to an overloading of the mechanical fastening elements of the antenna. Of course the wind pressure area will also be larger and both the dynamic and static properties of the mast construction will be totally different. Many satellite earth stations, for example, are operating in such geographical areas where wind loads are relatively high. For these circumstances some specific antenna types have been developed (e.g., a Kevlar-fibre based grid construction). It is thus reasonable to take a closer look at how the wind and ice loads should be taken into account.

Practical design is supported by several standards, norms, and instructions, which are meant to be used when estimating the effects caused by wind pressure. Probably the most used ones are Eurocode 1, ISO DIS 4354 and ASCE 7 standards. Scientists [3] have found differences in definitions and calculation instructions of reference wind velocity, exposure factor, turbulence intensity (at specified height), gust factor, spectral density functions of gustiness, and peak factors for the largest extreme value of velocity pressure.

According to [3] these standards are focused in determining design loads and they contain accurate procedures for calculating wind effects of buildings and other structures. However, there still seems to be a lack of

international harmonization of meteorological, structural, and aerodynamical data used for calculating static and dynamic design wind loads.

On the other hand, most manufacturers have circumvented the problem by establishing their own instructions. For example, two wind velocities are considered in the structural analysis: a low operational (telecommunications) and an ultimate tower survival velocity. Alternatively, the wind pressure caused by antennas is classified according to antenna type. For planar antennas the shape factor equals 1 and only the perpendicular pressure is necessary. For a parabolic antenna the axial load, lateral load (normal to the antenna axis), and torsion moment should be calculated. For grid antennas the values are calculated with no ice and with maximum ice forming. Rotation can seriously hamper the operation of telecommunication towers due to the narrow horizontal beamwidths. Often difficult calculations are passed by selecting a safety factor that is too large instead of an appropriate static and dynamic design process.

The exact calculations of wind loads include the interaction wind field and its mutual appearance with the structures. This necessitates an interdisciplinary approach, which involves meteorology, fluid dynamics, some statistical theory of turbulence, structural dynamics, and probabilistic methods. The wind itself has two "components," the mean component and the fluctuating component. These cause the wind load in the structure. The loads can be divided into four elements: (1) the along wind component (also known as parallel wind), (2) the across wind component (also known as perpendicular wind), (3) the torsion component, and (4) the vortex shedding effect. The first three basic items are easy to understand in a mast construction. The along wind component leads to a bending and swaying of the structure in the direction of the wind.

The across wind component constitutes a swaying motion perpendicular to the direction of the wind. Next, the torsion component results from imbalances of the pressure distribution near the mast (e.g., due to an unsymmetrical mounting of several antennas). This load causes rotational deformations of the mast construction starting from its base. The across wind component has additionally a critical effect on the generation of vortex shedding and by inducing various kinds of flow fields around the antennas. The wind load due to the known wind velocity against a surface area would be easy to establish. The difficulties start when the effects of gusts should be taken account. The main problem is how to establish a "standardized" wind with known gusts, which will last over a known period. For these purposes many kinds of probabilistic tables have been written. In practical design the problem is usually solved by using a gust loading factor, which usually is

acceptable for along wind loading. It is also difficult to establish an exact wind power spectral density (which also takes into account the wind fluctuations) and so called aerodynamic forces of each specific antenna construction without detailed wind tunnel tests. However, for certain geometries there are useful tables to consult.

According to [4] the cross wind and torsion responses cannot be treated in terms of these gust factors in as much as they are induced by the unsteady wake fluctuations, which cannot be conveniently expressed in terms of the incident turbulence. As a result, experimentally derived loading functions have been introduced and across wind and torsion load spectra are available in literature. They have been obtained by synthesizing the surface pressure fields on scale models of typical building shapes. Scale models of basic building configurations, with a range of aspect ratios, have been exposed to simulated urban and suburban wind fields to obtain mode-generalized loads.

To avoid either pure static torsion moments near the antenna fastenings or to prevent extra torsion in the mast base due to wind the antennas should be assembled as close to the nearest vertical bar as possible. If the mast is built of elements it is important that the joints (e.g., bolted flange joints) are manufactured and finished carefully. Even slight lengthwise errors in the vertical bars could lead to a large unsymmetrical loading. In general the gust effect factor is defined as the ratio of the maximum expected response to the mean response. When determining this factor both the background vortex effect and resonant vortex components are taken into account. The effects of the regional wind conditions and the height of the structure are taken into account with specific characteristics.

According to [4] so-called aeroelastic effects can sometimes have significant contributions to the structural response. They include vortex-induced vibrations, so-called "galloping," flutter and aerodynamic damping. The shedding of vortices generates a periodic variation in the pressure over the surface of the structure. When the frequency of this variation approaches one of the natural frequencies of a structure, vortex-induced vibrations can occur. Galloping occurs in structures having certain cross sections at frequencies below those of the vortex-induced vibration. One example is the large across-wind amplitudes exhibited by frozen power lines. This is also possible in guyed masts if they are exposed to rapid ice forming. If the pure wind pressure with the gust effect has generated a swaying and bending of the mast and it starts to flutter due to insufficient aeroelastic properties, these vibrations can boost dramatically.

Because the natural frequencies of a mast depend on its rigidity, the mass distribution along the mast, and the damping properties it is necessary

to make the wind load calculations also for icy masts. Individual antennas also have an aerodynamic damping effect because of their windfall losses. It is obvious that wind loads (either due to a known gust effect or due to the vortex effect) can expose the mast constructions to fatigue failure as well.

The design procedure of a radome is vital when trying to minimize the ice forming effect of the antenna itself or the wind pressure area and the vortex effect. These aims can be achieved with an appropriate shape and material selection but as a compromise. If the antenna is inside a well-shaped radome it usually prevents ice forming but the projection area of the antenna increases in one or two directions.

In a brief wind load analysis, the designer should first find the kinetic pressure of the wind at the desired height. Then, the mechanical and aerodynamic damping characteristics of the structure must be evaluated. The value for resonant vortex effect is computed, as is the value for background gust energy. Following these, the projection area of the structure against the main wind load, the shape factor and the final gust factor must be found. Then we are ready for the total wind load, the wind pressure distribution around the structure, the maximum bending and torsion and the critical natural frequencies. Finally, the fatigue life should be defined.

References

- [1] Johnson, R., *Antenna Engineering Handbook*, New York: McGraw Hill 1993.
- [2] Fujimoto, K., and J. James, *Mobile Antenna Systems Handbook*, 2nd ed., Norwood, MA: Artech House, 2001.
- [3] Lungu, D., and P. van Gelder, *Comparative Study of Eurocode 1, ISO and ASCE Procedures for Calculating Wind Loads*, hydr.ct.tudelft.nl/wbt/public/gelder/page8.pdf, Dec. 16, 2001.
- [4] Kijewski, T., F. Haan, and A. Kareem, *Wind-Induced Vibrations*, www.nd.edu/~nathaz/publications/wind/manuscript.pdf, Dec. 16, 2001.

Part 4

Test Arrangements and Results of Microwave Components Manufactured with Alternative Technologies

15

Mechanical Measuring Equipment

As stated earlier in this book, many of the final electromagnetic characteristics in passive microwave components are defined by their physical dimensions and shapes. A general rule of thumb is that uncertainties should be kept below 3% of wavelength if nothing special is required. At 34 GHz, for example, this yields to about 0.2 mm. Far smaller uncertainties are required, for example, in tuning structures or at the mating surfaces of connectors or waveguide flanges. High-Q resonators might even fall into the sub- μm category. Also, if the overall dimensions of, for example, rectangular millimeter-wave waveguides shrink down to less than 1×2 mm (cross section) we may easily need an internal surface quality approaching some μm . On the other hand, simple mechanical assembly-related needs or those coming from moving interfaces may dictate a stringent error requirement.

15.1 Dimensional Uncertainties

The research area of dimensional uncertainties of microwave components can be divided into three main subjects: (1) dimensional accuracy of individual components, (2) mutual assembly of individual components inside a construction, and (3) alignment of cooperating transmitters and receivers (e.g., in industrial systems).

15.1.1 Measuring Dimensional Uncertainties

All traditional and commonly used equipment for dimensional measuring is applied for the quality control of microwave products. It is recommended

that, in high technology manufacturing of microwave mechanics, 3-D coordinate measuring systems for each axis are used. This method is the most accurate way to control dimensional tolerances, and it also gives information about the geometric shape and location of each individual item to be manufactured. Note that the measured dimensions should also include the possible coating thickness of the product.

15.1.2 Measuring Geometric Tolerances

There are a few aspects dealing with the use of geometric tolerances, which need a detailed explanation here. Typically the careless use of geometric tolerances includes three basic mistakes. Either there is confusion between the use of tolerances for single features or for related features or there is confusion between the use of those geometric tolerances, which determine only the properties of a component's cross section instead of setting three-dimensional requirements. The third typical mistake is that there is confusion between the selection of the datum feature for either pure functional purposes of a complete assembly or for quality control of an individual component.

In theory, a "datum" is an exact point, axis, or plane derived from the true geometric counterpart of a specified datum feature. A datum is the origin from which the location or geometric characteristics of features of a part are established. However, in practical engineering a datum feature is an actual feature of a part that is used to establish a datum. Center lines and center planes are theoretical. They do not exist as features on an actual part and, therefore, may not be used as datum features. A datum is selected on the basis of its geometric relationship to other features and the functional requirements of the design. For mating parts, it is usually desirable to select corresponding features on each part as datum features to ensure proper interface in assembly. However, if the mating parts are manufactured in different factories the datum should never lie on the surface of the separate component because this would make it impossible to check the quality of the individual part before assembly! This is probably one of the most difficult rules to accept for the designer. In addition to this datum features must be readily discernible on an actual part, be accessible and be of sufficient size or extent to permit their use for manufacturing and inspection activities. Let us consider these questions with some examples, which present a typical sampling from microwave mechanics.

The meaning of geometric tolerances for single or related features is basically connected with the question: Do we need some datum surface, plane, line, or other feature to be fully able to understand the meaning of the

tolerance area? Tolerances for single features (which do not need any datum feature) are straightness, flatness, circularity, cylindricity, profile of a line, and profile of a plane. We can see that all these properties describe the accuracy of the shape or the profile of the component. We can give a value (e.g., for cylindricity) without comparing this property to any datum or theoretically true feature. Tolerances for related features (which always need a datum) are as follows: parallelism, perpendicularity, angularity, position, coaxiality, symmetry, run-out and total run-out. It is quite easy to understand that if there is no datum plane (e.g., for perpendicularity), then it is impossible to set a requirement that some component or part should be perpendicular against “nothing.” If a designer forgets to mention which surface is the datum surface, the error for related features is dramatic and could lead to serious mistakes during manufacturing and quality control. It is more difficult to understand what an appropriate datum surface is inside a construction. Let us assume that a construction consists of several components, which are manufactured in several companies, and then the assembly is made in one additional factory. In order to ensure the quality of each individual component, we cannot allow a datum feature defined on the surface on another component, which is made in another place. The measurement would be impossible. On the other hand, if we are testing the functional properties of the construction or if we are setting requirements for the assembly work itself, we absolutely need to select a datum surface, which usually is on the surfaces of separate components. Geometric tolerances, their symbols, and their appropriate use are presented in the international standard ISO 1101 [1], ISO 2768-2 [2] and ANSI Y14.5M [3].

In Figure 9.2 we gave an example of a microwave filter that consists of separate milled components. The center conductor includes several resonator rods that are all machined from one part only together with the body. If we require resonator straightness only, it is possible that we have exactly right dimensioned and correctly shaped rods but their position against the body might be false. To avoid this we recommend that the requirement of perpendicularity is set. The filter body is a good datum plain if the center conductor’s manufacturing quality is to be checked before assembly. In some cases it seems to be hard to understand this difference between the tolerance area for straightness and that for perpendicularity. In both cases, the area is actually a 3-D volume of an orthogon. Tolerance values are set in the drawings to be the height h and width w . The real difference is that if perpendicularity is required this orthogon should be perpendicular against a datum plain (see Figure 15.1). In the manufacturing documents the requirements of geometric tolerances are indicated by using standardized symbols. This symbol is a rectangular frame,

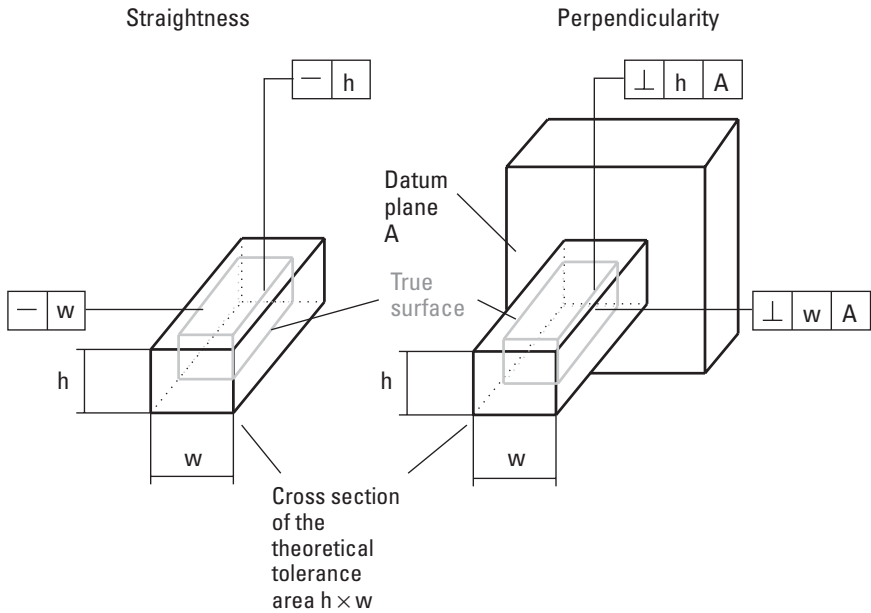

Figure 15.1 The main difference between straightness and perpendicularity is the following: Because perpendicularity is a tolerance for related features, a datum plane is necessary to determine the surface against which the comparison of the true position should be made. In the discussed filter construction, the resonator rods should be perpendicular in both xy - and zx -planes against their body (see also Figure 9.2).

which includes in sequential order the symbol of the geometric tolerance, identifying letter for the datum reference when needed, and the tolerance value (dimension h , in Figure 15.1 and dimension d in Figure 15.2).

In Chapter 7 in Figure 7.6 we presented a second example of a radio frequency bandpass filter where the center conductor is a sheet metal part. In this specific construction the most critical manufacturing stages are the cutting process of each strip and the assembly accuracy of the pair of center conductors. This means that two geometric tolerances could be required in practice. First both individual sheet metal conductors should meet the requirement of flatness. However, because the dimensional limits to ensure maximum performance are quite strict we have to set also the requirement of parallelism of the strips with the filter bottom. Here the requirement of flatness only means that the strips have to be between two ideal planes, which are at the distance d from each other (see Figure 15.2). The requirement of parallelism connects this definition with the datum feature. It means that

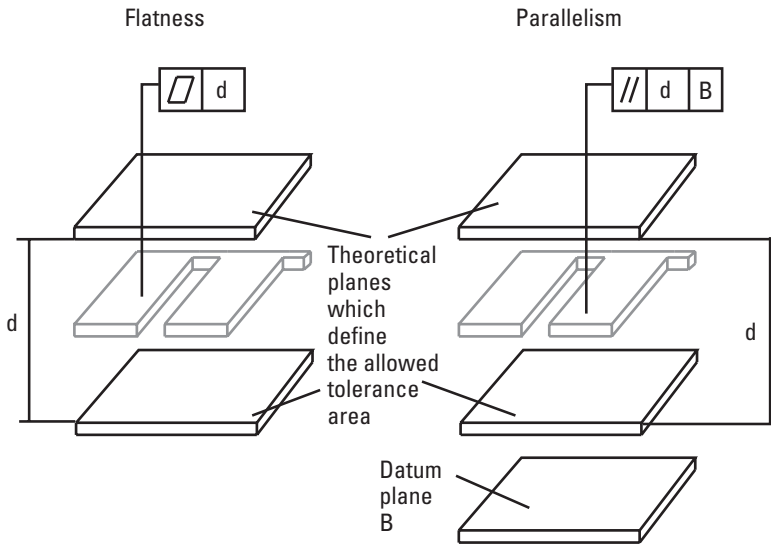

Figure 15.2 Principal differences between the requirements of flatness and parallelism. In both cases the acceptable tolerance area is the distance d between two ideal planes but parallelism needs a datum feature, which is theoretically parallel with those two ideal planes, whose distance from each other is d . A part of the center conductor is indicated in gray. To ensure the quality of the cutting process a requirement of flatness also is necessary for the sheet metal parts (see Figure 7.6).

these two planes should be parallel with the bottom of the filter (but the distance d is still valid!).

In many cases, it seems too difficult to choose the most appropriate geometric tolerance to ensure performance. An illustrative example is the situation in which the designer has to consider what the theoretic tolerance areas are (e.g., for circularity, cylindricity, or coaxiality), and what the practical differences are in using these requirements. This problem is encountered, for example, when trying to define the manufacturing parameters for a coaxial resonator or a cable, which may be of totally rigid nature. Circularity describes only the properties of each cross section of the component. We can imagine two ideal circles drawn with same center point with different diameters. The tolerance area is between these two diameters. Cylindricity extends this concept into the 3-D world. Now we have two ideal tubes and the tolerance area is between these two tubewalls. And finally coaxiality connects several ideal cylinders with each other and the requirement is actually set for the centerline of connected cylinders. Figure 15.3 illustrates these differences.

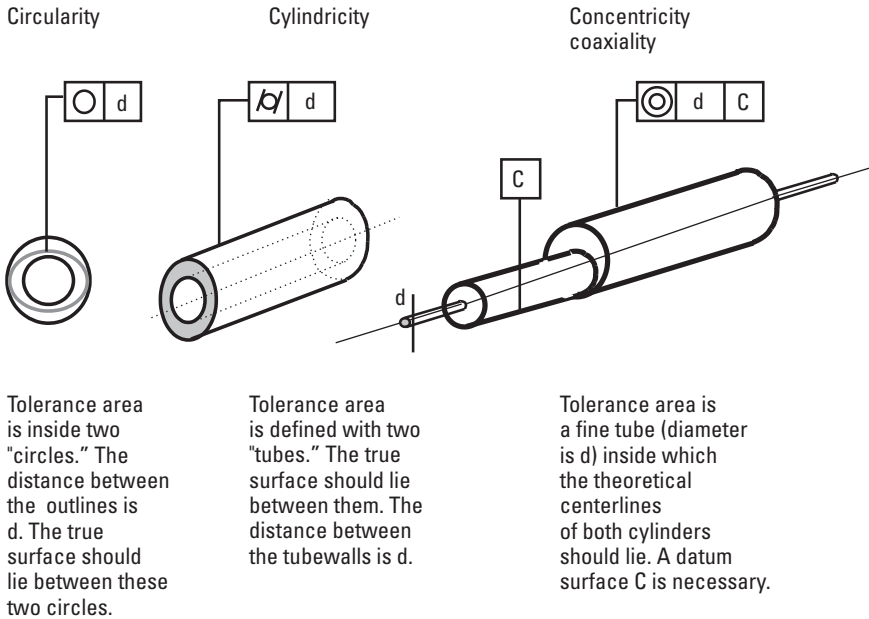

Figure 15.3 Circularity concerns only each cross section of a component. If 3-D requirements are necessary, cylindricity should be required instead (right). Even though circularity and cylindricity requirements are met we still need the requirement for coaxiality to ensure that the center axes of two connected cylinders are aligned (left).

A practical example of this type of difficulty (selecting between 2-D or 3-D requirements) is the combination of a rectangular waveguide and a pyramidal horn aperture that was presented with the wood quality measurement system in Chapter 13 (see Figure 13.5). Both the quadratic profile and the conical open profile of this Ku-band horn antenna should be accurate in each cross section. Further the straight profile and the conical one should be parallel. These two parts should meet the requirements of coaxiality in both xy - and zx -planes as well.

Too often, designers seem to use the diameter symbol (\varnothing) before the value of the tolerance. In the case of perpendicularity (see Figure 15.1), for example, this symbol could replace the two necessary requirements of perpendicularity (one for each plane), and it would change the tolerance area from an orthogon into a cylinder. In some cases, this might be acceptable and the change won't disturb the functional aspects of the product. These changes, however, should never be made without careful consideration. One

example where the use of the symbol ϕ would cause misunderstanding is the previously mentioned waveguide construction (see Figure 13.5). If we require just parallelism with the ϕ -symbol between the conical and straight parts, it would not prevent the possible twisting error of the part as illustrated in Figure 15.4.

Standard ISO 1101 presents several types of measuring arrangements that are recommended for each geometric tolerance. For practical design work standards give a possibility to utilize so called general geometric tolerances. This means that there are certain values, which can be set without making any specific indications on each single item of a drawing. Only a brief notice is needed in the title block of the drawing. Standardized values for the following geometric tolerances are available: straightness, flatness, circularity, parallelism, perpendicularity, symmetry, and circular run-out. Although the use of general tolerances could make the design work easier there are several aspects that should be considered before relying solely on them. If no indications are made in the drawing it is difficult to decide if the datum feature is chosen to control the performance, assembly or manufacturing of an individual part. In practical work in industry the tolerance values remain unknown if the standard tables are not available. It is also important to notice that the required tolerance grade depends mostly on the frequency range of the microwave device and the use of general tolerances might cause serious underestimations if the real frequency is high enough. For the assembly work it is necessary to point out that although the values for general tolerances would be available, the real symbols on the drawings will always give

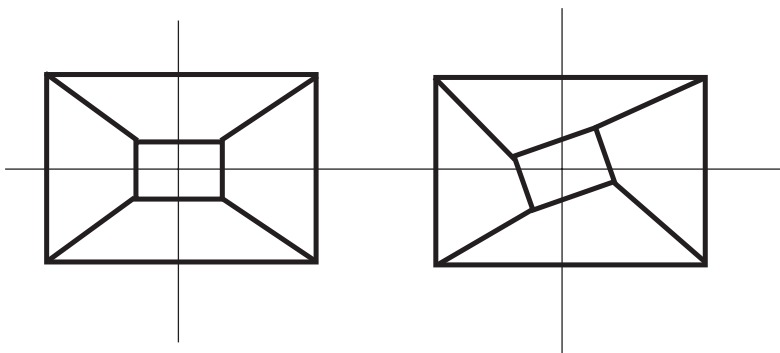

Figure 15.4 A schematic front view of the horn antenna already presented in Figure 13.5. Parallelism with a ϕ -symbol between the conical and straight parts would not prevent the possible twisting errors.

some useful information for the assembly phase. For microwave mechanics we therefore highly recommended that the most important geometric tolerances are always written on the drawing and general tolerances are used only for components in which the accuracy requirements are less important. More detailed information about the use of general tolerances is given in standards EN 22768 and ISO 2768-2. The CD-ROM, which is attached with this book, includes several detailed drawings of real microwave devices. The reader is encouraged to check there the practical use of geometric and general tolerances.

15.2 Joint Reliability

The term of “joint reliability” could be understood in two ways: Either we are talking about the electrical contact between associated parts or we can also discuss the mechanical joint reliability. Let us omit, in this chapter, the question of electrical contact, and let us focus on the pure mechanical aspects. The most important aspects will be the long time reliability of the joint (either fatigue or corrosive failures), maximum bearing capacity of the joint (depending on the load) and the metallurgical properties of the joint (e.g., properties of the welded or soldered joint). Measurement systems for mechanical properties are either developed for material testing or for measuring the properties of a product itself. The most common and standardized tests for material properties are tension, torsion, bending, fatigue, and impact test. There are several variations of these tests (e.g., for welded or soldered joints) and for tests for various environmental circumstances. In MW devices, the fatigue loading could be caused by temperature fluctuations, for example, which initiate dimensional changes in various materials. This could further lead to tensile or bending stresses inside a construction. It is also important to determine fatigue properties for welded constructions in which practically any error in a welded joint could be a potential reason to launch fatigue phenomena.

15.3 Surface Properties

The main groups of phenomena, which can cause different kinds of physical surface defects, are chemical or metallurgical changes of the surface, changes of surface properties during the manufacturing process of bulk material or the product itself, mechanical composition of surface texture, changes of the

hardness profile, and wear. Let us consider these phenomena from the microwave design's point of view.

15.3.1 Oxide Layers

On many metallic materials an oxide layer (FeO , Fe_3O_4 , Fe_2O_3 , Al_2O_3 , Cu_2O , CuO , CrO , or Cr_2O_3) starts to form immediately after the manufacturing processes of the bulk material. In microwave applications this oxide layer significantly changes the properties of the component (electrical and magnetic properties of the surface) and should therefore be taken into account during the material selection phase. It is also known that these oxide layers are much harder than the base material itself and that's why they can act as abrasive wear particles between adjacent mating surfaces. For example, aluminum—the most common material—has an oxide layer, which is about 70 times harder than the base material. The oxide layer of copper is only 1.6 times harder. On the other hand, these layers can protect the base materials (e.g., against corrosion) [4, 5].

15.3.2 Surface Defects Caused During Manufacturing Processes

These defects can be classified into two groups [4, 5].

Surface defects caused during the manufacturing of bulk material:

- Inclusions (e.g., steel manufacturing process);
- Metallurgical transformation (e.g., rolling);
- Plastic deformation (e.g., rolling).

Surface defects caused during the manufacturing process of the product:

- Cracks (e.g., welding or casting);
- Craters (e.g., welding or casting);
- Heat-affected zones (e.g., thermal cutting or welding);
- Inclusions (e.g., welding or casting);
- Plastic deformations (e.g., drawing or forging);
- Splatters (e.g., welding or casting).

Only metallographic tests will exactly ensure that the raw material does not include these kinds of defects near its surface. Samples from the work-piece are removed, polished, etched, and analyzed under an optical or electron microscope. If we can assume that those errors appear also on the surface, nondestructive techniques such as use of liquid penetrants, magnetic-particle inspection, eddy-current inspection, or holography can be applied. The defects that open directly on to the surface are most harmful in microwave devices because they are relatively deep defects and they can more act like “reflecting pockets” for microwaves. This can cause therefore unwanted propagation modes. It is also important to notice that in rotational (or other moving) joints the die surface of a slide-ring will be disturbed. The second group of defects (metallurgical changes) can possibly have an effect on the electromagnetic properties of the selected material and is therefore important if either welding or casting is used during the manufacturing stages of the microwave product.

15.3.3 Mechanical Composition of the Surface Texture

The geometric properties of a component's surface consist of several elements. Unlike usually expected, roughness is just one of the typical characteristics used for describing the surface quality of mechanical microwave components. Further it is in many cases even deficient to give an estimation of the functional properties of the surface. A better estimate requires at least some knowledge of the following properties:

1. Size and shape of different types of individual irregularities (like flaws, scratches, cracks, holes, depressions, seams, tears, or inclusions);
2. Directionality of the predominant surface pattern that is characteristic for each manufacturing technology and tooling system;
3. Surface roughness (usually the R_a -value is used, although it gives only an arithmetic mean value of the roughness);
4. Waviness of the surface (usually caused by several factors during the manufacturing process);
5. Dimensional errors of the surface (either errors in the shape or even of location).

If we omit all the special microwave test arrangements, in which the mechanical parts are typically of overquality, we get the result that better

surface roughness than $1.6\ \mu\text{m}$ is needed above 300 GHz! Waviness, however, which consists of periodic waves with the height of 0.1 mm and width of 25 to 30 mm, can significantly disturb or at least decrease microwave performance at much lower frequencies (e.g., in filters or resonators). In most cases the reason for waviness can be found from careless manufacturing. The main reasons are usually deflections of tools, dies, or workpieces. Other possible reasons might be force or temperature changes during manufacturing, vibration problems either with the machine body or tooling and different types of periodic mechanical or thermal variations in the manufacturing system.

Sealed microwave components and constructions call for extra attention on surface texture quality. Basically the common rules utilized in mechanical engineering are valid here, too. However, additionally to the proper use of the R_a -value there are several radio frequency components, which need absolute tightness against dust and moisture. In these cases it is recommended that also the value of maximum roughness height (R_q) is used to avoid the situation that one relatively large error on an otherwise excellent surface destroys the sealing performance despite of acceptable R_a .

15.3.4 Measuring Surface Roughness

There are four main technologies to observe the surface roughness:

1. Mechanical profilometers with a diamond stylus;
2. Scanning electron microscopes;
3. Optical interferometers;
4. Atomic force microscopes.

Surface roughness can be easily measured with profilometers. The most common devices use a diamond stylus, which is moved along a straight line on the surface. The distance that the stylus travels is called the cut-off. It is easy to understand that the selection of this cut-off length is vital when establishing the reliability of the measurement. To be able to get a solid estimation of R_a , the cut-off must be long enough to include at least 15 roughness irregularities. According to standards the typical stylus tip diameter is $10\ \mu\text{m}$, which means that the stylus cannot follow the surface exactly from bottom to top. Surface roughness can be directly observed through an optical or scanning electron microscope. Atomic force microscopes (AFMs) are used to measure extremely smooth surfaces, and have the capability of distinguishing

atomic scales on atomically smooth surfaces. This equipment is also used for getting three-dimensional views of a surface. There are several aspects that should be taken into account when deciding the value of R_a for a microwave component:

1. The functional requirements of the component:
 - Hermetic sealing for encapsulating semiconductor electronics ($R_a < 0,8 \mu\text{m}$);
 - Radial sealing for rotary joints ($R_a < 0,8 \mu\text{m}$);
 - Housings for ball bearings in rotating radar or antenna applications ($R_a < 1.6 \mu\text{m}$);
 - Inside walls of resonators and filters ($R_a < 1.6 \mu\text{m}$), depending on operating frequency);
 - Fittings between SMA-connectors or components, which are like ($R_a < 1.6 \mu\text{m}$).
2. Lubrication considerations:
 - Depending of the directionality of the predominant surface pattern it can be even useful for lubrication by moving the oil within the grooves;
 - In slide-ring constructions the pattern can cause serious vibration problems;
3. Friction properties of the surface will change (see above), however, the selected material pair is important;
4. The electrical and thermal contact resistance of the surface will increase if the surface is rough;
5. Depending of the designed coating of the microwave component a bit rougher surface can give better bonding for the coating;
6. Fatigue life will decrease due to a rougher surface (any components, which are exposed for outside loading);
7. Corrosion resistance of a rougher surface is lower against environmental loading. (e.g., components for outdoor antenna constructions).

All these factors should be considered prior to making a decision about the specifications on surface roughness for a particular part. As in all manufacturing processes, the cost involved in the selection should also be a major consideration.

15.3.5 Friction Measurement

There are some special microwave devices, which are tightly related to the design of rotational mechanisms, (e.g., rotary joints presented in Chapter 9). For these purposes it is important to know some basic ways to determine the friction coefficient of a surface. The coefficient of friction is usually found experimentally by using small-scale specimens of various shapes. The techniques used to calculate the coefficient of friction generally involve measurements of either forces or dimensional changes in the specimen.

15.3.6 Wear Measurement

Those mechanical microwave constructions which include, for example, bearings, rotary joints, or slide-rings, must be designed with an ability to control wear during the whole lifetime of the device or system. There are several means to measure wear:

- Measuring the dimensional changes of the surface;
- Using of gauges on the worn component;
- Using profilometry;
- Weighing (comparing the original weight to the weight of the worn component);
- Measuring vibrations or noise levels (worn mechanical components emit more noise and vibration and their spectral output is different to that of a new device);
- Analyzing the used lubricants.

In practice, there are four main types of wear: (1) adhesive, (2) abrasive, (3) chemical or corrosive, and (4) fatigue wear. We can make the following conclusions regarding mechanical microwave components:

- Corrosive wear is always a risk when components or constructions are placed under heavy environmental loading (antennas or radars). There are two important ways to prevent corrosive wear: (1) appropriate material and surface treatments (e.g., painting or coating), and (2) geometric design of the construction (no pockets or cavities in which moisture or contaminants can remain).
- Chemical wear is possible if the materials used form an electrochemical pair between the components (e.g., body and mounting

screws) or if the environmental loading enables the formation of some electrolyte liquids (e.g., so-called acid rains). Two methods are used to minimize the risk of chemical corrosion: (1) appropriate material selection, and (2) sufficient sealing of the construction.

- Adhesive wear is a phenomenon in which two surfaces tend to stick to each other due to either a lack of lubricant or, during heavy loading, the speed of motion being too slow. Certain material pairs have a tendency to stick to each other and should therefore not be used for these surface types. For example, aluminum and steel stick easily to each other. If there is a risk of adhesive sticking, two actions are recommended to avoid wear: (1) the use of appropriate lubricants, and (2) an appropriate surface treatment and material selection. A typical example of adhesive wear in microwave mechanics is slide-rings or bearings in rotating antenna or radar constructions.
- Abrasive wear is a phenomenon during which the surface is destroyed by a hard particle between two sliding surfaces. This item can be dust, dirt, a contaminant, or a slice of the oxide layer of the surface. In practice these particles grind the surface and the coating or hardened surface, for example, will be damaged. If the surface layer is broken through, the rest of the sliding component will be destroyed rather quickly. The main ways to prevent abrasive wear are: (1) use of appropriate surface hardness values (e.g., by utilizing heat treatments), (2) use of lubricants which are able to flush the abrasive particle out of the surface, and (3) use of dust gaskets to keep foreign items out of the construction. Abrasive wear also typically takes place in rotating mechanisms like in antennas, radar, and bearings.
- Fatigue wear is a phenomenon that destroys either the layers just under the surface or the surface layer itself due to a recurrent stress loading. The phenomenon can start from any inhomogeneous property of the surface. Therefore, it is important to take care with the quality of the base material and use accurate measurements to ensure that there are no errors on the surface. Typically this process takes place in gears and bearings. In theory some radar constructions might suffer from fatigue wear if the rotating speed is high enough and if stresses caused by mechanical loads are large enough to trigger it.
- Usually the four wear types appear at the same time, or one type leads to another phenomenon. For example, adhesive sticking can cause peeling of the oxide layer, which then starts to act like an abrasive

compound between the layers. The errors of the surface caused by these abrasive particles can further form an inception for fatigue wear. If the oxide layer is damaged, this also allows chemical wear to take place on the unprotected surface.

15.3.7 Hardness Tests

The most common standardized hardness tests are Brinell, Rockwell, and Vickers hardness tests. These three are the basic tests used in mechanical engineering and are suitable for evaluating the surface of general mechanical microwave components or for analyzing the results of heat treatments. The test impressions on the surface are usually regarded as defects and therefore the entire component is actually destroyed if these hardness tests are applied. However, for material testing it is possible to make a specific piece together with a cast product itself. All these tests and associated procedures are standardized in international standards. For some specific microwave devices we may use also other hardness tests. The Knoop test is suitable especially for analyzing very small or very thin specimens and for brittle materials, such as carbides, ceramics, and glass, which all are quite common in microwave applications. If there is a need to study metallurgical changes of the material used, this test can also be used for measuring even the hardness of an individual grain and component in a metallic alloy. The durometer is used for hardness test of rubbers, plastics, and similar soft and elastic nonmetallic materials. This method can be used, for example, for estimating the lifetime of microwave sealings or insulators, or their behavior under environmental loading.

15.4 Tests for Hermetic Enclosures

One possibility to ensure the long-time reliability of microwave devices is to measure the hermeticity of associated enclosures. In its traditional purposes the standardized test (e.g., according to MIL-STD-833, [6]) is used to ensure that no moisture or impurities would get inside the enclosure and to prevent the shielding gas to leak out of the housing. These tests can be applied also to study the atmosphere inside the cavity after the joining process. It is possible to find out which gases or chemical compounds are evolved inside the housing during a joining process. Some nitrogen based gases, carbonic anhydrides, chlorines or their compounds, for example, might be harmful for the long time reliability of the electrical components especially if some moisture is additionally concentrated inside the cavity.

The most commonly used tests are as follows:

- In so-called fine leak testing, helium is used as an indicating gas. The specimen is placed in an overpressurized chamber in which helium gas is led. Then the specimen is moved in to a second chamber where the leak is measured with a mass spectrometer.
- In so-called gross leak testing, fluids and colorants are utilized. A fluid (indicator fluid) having a relatively high vapor pressure is forced into the specimen under a high pressure. Then the specimen is dipped inside an inert liquid chamber. The liquid inside the chamber is then heated to above the boiling temperature of the indicator fluid. This causes the indicator fluid to evaporate and it starts to leak out of the specimen.
- Weight gain measurements are based on simple weighing of the specimen before and after pressuring. If the mass increases due to higher pressure, the cavity obviously leaks.
- Particle impact noise detection (PIND) test is based on standard MIL-STD-833 Method 2020. This method is used to indicate particles, which might cause damage to semiconductors or IC chips in a cavity or enclosure. The cavity is exposed to vibration, which causes particle impacts against the walls of the cavity. The acoustic waves (frequency range of 100 to 300 kHz) caused by these impacts are then measured and analyzed.

Internal water vapor content test (according to MIL-STD-883 Method 1018) is used mainly to measure the humidity or moisture content inside the housing after joining or other manufacturing processes. The humidity is first condensed on to the walls by using an elevated temperature. Then the specimens are broken through and the amount of moisture can be measured.

References

- [1] International Standard, ISO 1101, "Technical Drawings—Geometrical Tolerancing—Tolerancing of Form, Orientation, Location and Run-Out. Generalities, Definitions, Symbols and Indications on Drawings," 1983.
- [2] International Standard, ISO 2768-2, "Geometric Tolerances for Features Without Individual Tolerance Indications," ISO Central Secretariat, 1989.

-
- [3] American standard, ANSI Y14.5M-1994, "Tolerances," 1994.
 - [4] Kalpakjian, S., and S. Schmid, *Manufacturing Engineering and Technology*, New Jersey: Prentice-Hall Inc., 2000.
 - [5] Wright, P. K., *21st Century Manufacturing*, New Jersey: Prentice-Hall Inc., 2001.
 - [6] Military Standard, MIL-STD-833, *Electroexplosive Subsystems, Electrically Initiated, Design Requirements and Test Methods*, USAF, Jul. 31, 1963.

16

Selecting Microwave Test Instrumentation

Radio frequency measuring instruments are expensive, but even the simplest passive mechanical components, such as coaxial connectors, cannot be accurately judged without a number of instruments. The most important ones for the definition of microwave performance are the VNA, the spectrum analyzer, and various signal sources, which are known as microwave generators. High-quality coaxial cables, adapters, and waveguide components such as bends, flanges, and transitions must be at hand, too. A network analyzer is quite useless if a calibration kit is not available. Sophisticated tests require the use of isolators and directional couplers. A simple microwave spectrum analyzer costs about \$30,000 and a VNA costs about \$50,000. A reasonable alternative may be a second-hand unit, but purchasing requires knowledge and a bit luck as well. Conventional microwave test instruments do not become technologically obsolete and they are used until their reliability starts to fall.

A background of microwave engineering is needed before starting measurements with these instruments. Some of the most straightforward tasks can also be thought to be performed in mechanical workshops. One of the main reasons for this is the clarity obtainable in the results. An impedance plot reveals immediately if something went wrong (e.g., during a connector mounting), whereas tedious physical measurements might give a completely misleading indication. The following short sections describe the

key characteristics of the most vital instruments and make some suggestions about their use in the evaluation of mechanical components. The reader is not encouraged to rush, but with some practice, you might well succeed. If nothing else helps, consult the manual!

16.1 Vector Network Analyzers

A vector network analyzer is used for the measurement of scattering parameters. They define the input and output matching of a construction and show how a signal propagates through it. Most analyzers have a capability of simultaneous two-port tests, which means that we do not have to turn the device during the sequence. Components, which we can evaluate, range from coaxial-to-waveguide transitions to power couplers, ring hybrids and filters. Naturally, active microwave devices are tested too, but such measurements require quite extensive microwave knowledge. Attenuation is usually expressed in decibels (which is a logarithmic scale), phase shift and group delay are expressed in a linear scale in degrees and time versus frequency, respectively. However, typically the VNA is used in its frequency sweeping mode and impedance or attenuation is shown as a function of frequency. The operating principle relies on a radio transmitter, which changes its frequency. The VNA has also a receiver, which continuously tracks the frequency of the transmitter and we are thus able to plot the performance from one frequency to another. The Smith chart is a very informative impedance display format. Many professionals, too, sometimes prefer to view a logarithmic plot of return loss or standing wave ratio (SWR). For attenuation, phase shift or group delay, conventional rectangular scales are used. Sometimes a polar amplitude plot is practical but its evident drawback is the linear nature. A measurement task usually begins with the calibration of the VNA. This can be initiated after we have defined the frequency range and the number of measuring samples. The complete two-port calibration is one of the more accurate procedures. It involves a successive series of opens, shorts and loads followed by a through connection for S_{21} . Naturally we have to use test cables of adequate performance and flexibility. Also, the calibration kit must be of required quality. Normal SMA connectors are not available as a calibration interface but we can use the 3.5-mm device as a mechanically compatible substitute. Measurements of mechanical microwave devices, like filters, are not likely to destroy a VNA if we just avoid static discharges. The source power can normally be kept as it is but for measurements of very steep and high performance filters we may need all that is available. Another issue is the

sweep time. The more averaging is allowed, the more slowly is our measurement but this choice reduces noise. We can use a narrow intermediate frequency (IF) bandwidth if the best sensitivity is needed (e.g., when trying to define the isolation of the ring hybrid presented earlier). The main VNA defect in all these measurements due to improper handling is test port connector destruction. This is of mechanical origin and can be avoided by the use of appropriate adapters or by flexible test cables and their protection adapters.

16.2 Spectrum Analyzers

If we need to have a look at the microwave signal in the frequency domain, a superheterodyne spectrum analyzer is the proper choice. Commercially available instruments show the amplitude of signals on a decibel scale and cover frequencies from some tens of kilohertz up to about 300 GHz. The dynamic range is typically better than 80 dB but the best sensitivity is not in use if we require low distortion as well [1].

Three major applications for a spectrum analyzer can be found in the testing of passive microwave components. It is possible—to some extent—to substitute a VNA with a combination of a spectrum analyzer and a signal generator although we lose phase information. Intermodulation measurements are made with a high quality spectrum analyzer, because of the necessary dynamic range and the relatively good IF selectivity. The third task is antenna pattern measurements in those cases where a VNA cannot provide the required selectivity. The conventional spectrum analyzer is composed of a microwave mixer, a suitable local oscillator and a selectable filter. Detectors, logarithmic amplifiers, step attenuators, and display interfaces are needed, too. The sweep of the local oscillator brings successively each signal into the pass band of the filter and thus we can measure, one after the other, the amplitude of each individual component. The sweeping nature is one of the greatest drawbacks of a spectrum analyzer. It means that a time varying signal may change its character during a sweep and the display is thus false. Another difficulty is the mixer interface, which may generate phantom signals or spurious responses. For example, a reliable recording of PIM values is severely hampered by this process.

The time needed for one frequency sweep is proportional to the frequency span but also depends on the wanted resolution. Sweep times exceeding ten seconds are not rare and for the best sensitivity we must sometimes use video averaging. We need 100 sweeps in order to reduce video noise by

10 dB and this takes the time of 100 real sweeps, for example 1,000 sec, if each sweep takes 10 sec. Such a test method requires very good frequency stability and some thermal control as well. Spectrum analyzers are sensitive to DC voltages, static discharges and excessive radio frequency power in their input.

16.3 Signal Generators

A signal generator works in conjunction with the spectrum analyzer and provides a suitable test signal, the characteristics of which (after going through our design) will be recorded by the analyzer. Generators are available for frequencies from 10 kHz to 300 GHz and their output level can be varied from less than -100 dBm up to $+10$ dBm and even more. Normally these devices incorporate a variety of modulations but mechanical microwave component testing seldom needs those. Some devices have sweep options and almost all can be locked to an external frequency reference. Simple microwave generators are assembled from a stable oscillator, some amplifiers and a set of attenuators. Filters are added to improve signal purity. Very many microwave sources are synthesized, which gives better frequency stability but may create spurious signals. Low-cost generators do not have a precision step attenuator and their power range is limited. If only mechanical microwave components are tested, there is no great risk of damage. We should work at the lowest practical power level, because this reduces spurious emissions and normally gives best performance against poor impedance match. Applications, in which this advice cannot be followed, include PIM measurements and some antenna tests. The natural reason is the avoidance of thermal noise, which will come up in the receiving instrument at around -130 to -80 dBm, depending on selected bandwidth. If an external power amplifier is coupled to the generator, strict safety rules should be followed [2]. There is a risk of equipment damage and a very high power microwave signal can be harmful to eyes.

A very common mistake happens if the power levels of a generator and a spectrum analyzer are not mutually compared prior to a component measurement. Just the manufacturing tolerances can bring an uncertainty larger exceeding 2 dB between the two devices and any cables needed in the test set up may add another two or even more. Although a real calibration is not possible (e.g., due to the rather arbitrary impedance conditions), some kind of power loss compensation should be accomplished. This can be done by simply connecting the signal path from the source up to the analyzer without the

device to be tested. Many spectrum analyzers are able to record this process in to their display memory and the result can be later automatically subtracted from the real test recording.

16.4 Cables, Connectors, and Some Accessories

These small items may define the success or failure of our microwave measurement. A general rule is that quality equals spent money. Use only cables of proper radius in order to prevent unwanted modes but take the largest practical to achieve low attenuation. Connectors should preferably be of same series as those on the unit to be measured. If possible, select SMA, K, 3.5 mm or N type interfaces. A disastrous combination for microwave tests is RG-58 cable and BNC connectors. If the design, which should be tested, has waveguide flanges, it usually means that the measuring environment should also rely on the same guide. Transitions and coaxial cables should be the correct ones. Do not mix the wall direction. Separate microwave isolators and filters are sometimes very useful for matching or for interference rejection. Commercial ferrite isolators give about 20 dB of attenuation in the reverse direction but have 1- to 2-dB loss in the forward path. The frequency range and power handling are limited. Small, laboratory-grade devices can take up to 100 mW. Filters are available both as tubular coax designs and as waveguide modules. Custom frequencies are typically expensive and their delivery times are measured in several months. Off-the-self units are manufactured for most commercial or military system frequencies but very often their frequency response does not meet the test arrangement's needs. Sometimes it is possible to combine separate low and high pass units to create a semicustom bandpass or band reject filter. The insertion loss of a high-quality filter is seldom above 1 dB.

References

- [1] Coombs C., *Electronic Instruments Handbook*, New York: McGraw-Hill, 1995.
- [2] Kenington, P., *High-Linearity RF Amplifier Design*, Norwood, MA: Artech House, 2000.

17

Examples of Practical Test Set-Ups

In this chapter we introduce some real measuring arrangements in which parameters typical for mechanical microwave components are analyzed. Although equipment types and manufacturers can be traced from the given information, the specific devices shall only be considered as examples of the breed. Many instruments of different makes will do the same job if needed. The reader is encouraged to use a textbook of microwave theory as supplementary reading because available space has precluded a more thorough treatment of various design issues.

17.1 Passive Intermodulation in Welded Components

As briefly mentioned in Section 1.1, microwave fields can cause intermodulation problems when they meet material discontinuities (e.g., in the vicinity of antennas, or near high-power radar stations) see [1]. Similar phenomena have been observed also inside transmitters. Basically the process generates on the surfaces of conductive parts unwanted signals as a mix of already existing ones. The difficulties have recently grown because more carrier frequencies are taken into use at the same geographical site and because the requirements caused by receiver architectures have become very tight [2]. For example, filtering of antenna signals in portable devices consumes space and such elements are easily discarded in the design phase. At the same time, immunity to interfering signals is no more guaranteed. The only way to

reduce intermodulation is to produce components without electrical discontinuities or at least to limit their size. Key factors are the size of the discontinuity and its metallurgical characteristics.

Fundamentally, intermodulation is a process, which produces from two or more original microwave signals a set of new, unwanted ones. In order to be of practical importance, the individual signal frequencies must both have such a value that also the intermodulation frequency falls within the passband of the system. We use the term passive intermodulation to indicate that only those unwanted signals, which are caused by pure mechanical components, are taken into account.

The possible intermodulation effects of joints were studied. We wanted to exclude the implications coming from geometry (e.g., burred edges or sharp corners due to arc welding), because laser welding seems to take care of them [3]. A closed rectangular stripline was used as the device under test. This gives high attenuation against external signals and a well-defined geometry for computation. The test joint is in the center conductor, whose surface is milled after the welding to precise dimensions.

The basic scheme of third-order intermodulation measurements needs two highly pure signals [2], originating from state-of-the-art synthesizers. The frequencies are adjusted so that the difference between the first multiplied by two and the second as such falls within the desired band of interest, see Figure 17.1. Two generators are coupled together through isolators, which reduce mutual interaction between the two outputs. After this, the signal pair is amplified in a highly linear device to about 10 or 100W and a band-reject filter is used to remove intermodulation caused by the active device. A spectrum analyzer is used to measure the power at the frequency of interest and normally a bandpass filter reduces the level of the original generator signals.

The performance of the welded joint or piece can be described in the radio frequency world as a mixer. The amplitudes of individual components are hard to predict and must in practice be measured. A typical result is shown in Figure 17.1, where the scale has been normalized to the initial signal. The dynamic range of the test arrangement must cover at least 150 dB.

Laser welding could be a solution for some cases including the assembly of antennas and the sealing of enclosures. The precise beam control minimizes the cross-sectional dimensions of a weld thus giving a smaller induced voltage. The improvement could be about 10 dB. Secondly, a number of tests have indicated only minor metallurgical discontinuities because the near-surface contamination of a laser weld can be kept within reasonable limits whereby 10 to 20 dB of reduction looks feasible. When using steel, precautions are necessary due to corrosion problems.

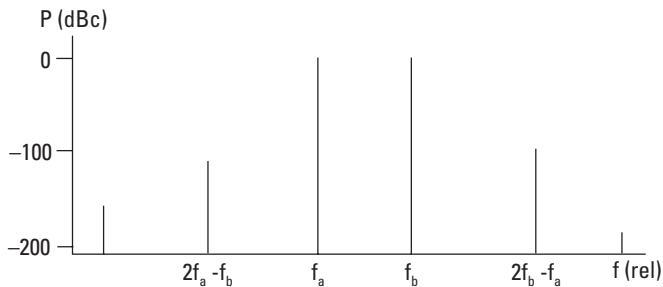

Figure 17.1 Measurements indicate that the highest intermodulation components (at $2f_a - f_b$ or $2f_b - f_a$) are generally 120 to 140 dB lower than the initial generator output.

17.2 Testing the Shielding Performance of Microwave Enclosures

Many times the only reason to use a metallic, mechanically manufactured enclosure for a microwave device is to achieve the required level of interference suppression. One gets a sturdy chassis as a by-product, too. Although already manufacturing is sometimes complicated, the real difficulty is in verification. This is partly due to the behavior of electromagnetic fields and partly to the interference coupling schemes.

If we work above 1 GHz, the typical largest box dimension is less than about 0.5m. At 15 GHz, we may see a device measuring only 2 to 3 cm. Three main alternatives exist. Some engineers prefer milled brass or aluminum boxes, which are very often tailored to the specific project. Also low-cost cast enclosures are used in prototypes. Sheet metal boxes are attractive in volume production and particularly if weight is of main concern. Prototyping is somewhat complicated, because the seam fastening practices are only feasible for high volume production.

Very seldom is a microwave device supposed to work without any physical connection to the surrounding world. This means that most enclosures have cable feed-throughs, connectors, switches, and buttons. Regardless, if we are measuring a real microwave system, the only way in which microwave energy can get in to or out of an all-metallic box is via its nonperfect seams. At far field distances, the measurements will indicate that more or less the whole enclosure acts as an antenna.

The testing of an empty enclosure can be accomplished either assuming the box to be the source or the target of electromagnetic waves. We need both a sensitive and selective receiver and a signal generator. Most notably we have to possess dedicated antennas, one for the receiver and the other for the transmitter. This can be one of the more problematic points, because it is

sometimes impossible to fit an antenna inside our tiny enclosure. All the stuff must be assembled and carefully positioned inside an anechoic test room and the box under test must be rotated to cover all imaginable angles of attack.

17.3 Experiments on the Input Impedance of Waveguide to Coax Transitions

A coaxial probe going through the broad side is one of the simplest means of coupling microwave power to rectangular waveguides as indicated in Figure 17.2. It is often made of a suitable panel-mounted version of a coaxial connector (type N, SMA, or K, for example) and an attached extension covering its center conductor inside the guide. The classic text by Collin in [4] and [5] seems to form the best-known theoretical background. A number of practical application examples are presumably not strict derivations of theory but more express the tough professionalism and long experience of the respective authors. Astonishingly some of the fundamental antenna handbooks (e.g., [6]) totally omit the discussion of probe-fed designs. When restricted to rectangular cross sections, we can simply define the two initial parameters in use: the short circuit position or the distance from it to the feed as l and the probe length d , see again Figure 17.2. Depending on the particular case, the termination may be considered as a real matched load or just as something of arbitrary impedance (e.g., a horn, a junction, or an active device) mounted at a distance from the feed point.

The very fundamental treatment in [4] shows that the resistive portion of the probe input impedance is

$$R_{IN} = \frac{Z}{2abk_0^2} \left| 1 - e^{-j2\beta l} \right|^2 \tan^2 \left(\frac{k_0 d}{2} \right) \quad (17.1)$$

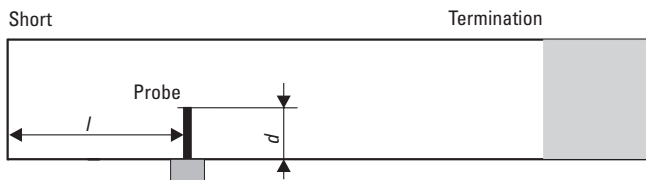

Figure 17.2 The basic configuration used in the tests was initially a probe-fed S or Ku-band rectangular waveguide, which was terminated with microwave absorbing material. The position of the short circuit (marked as l) and the probe length d were used as input variables.

where a and b are the guide dimensions, Z the relevant impedance (normally assuming air as the dielectric), and k_0 and β the common propagation constants. No special restrictions are given but the reactive portion has been further described in [5]. Of course, l and d in (17.1) can be optimized to give 50Ω . A terminated 800-mm piece of typical S-band waveguide operating near 1.7 GHz with guide dimensions as $110 \times 55 \text{ mm}^2$ was used next as a test bed. The calculated results suggest that although the free space wavelength is around 170 mm, an acceptable return loss requires submillimeter accuracies. Most of these measurements were performed with a fixed probe length (34 mm as found by trial-and-error) and by varying the position of the short. The probe diameter was $0.01 \lambda_0$. Naturally, the most common choice for 1.7 GHz or so, suggested in many practically oriented text books is the intersection at 40 mm yielding $(50 + j 0)\Omega$.

Probe positions near the quarter wave distance are properly dealt with by the approach of (17.1) but a notable drawback can be pointed out. It seems that feeds near the cutoff frequency cannot be dimensioned following its ideas. However, many antennas do not need more than a couple of wavelengths of waveguide and thus attenuation (in a “too small” guide) as such is not a problem. This is the case, for example, if the smallest size and weight are sought, and the next lower frequency standard guide would be 20% larger. Here, the theoretical model of (17.1) does not predict a good solution whereas practical measurements indicate a return loss better than 25 dB at 1.62 GHz and 1.58 GHz with short distances of 32 and 37 mm respectively.

We used a slot antenna array (16 radiating slots in total), partly shown in the photograph of Figure 17.3 and discussed in detail in [7] and [8], as a further case for impedance evaluations. The slots were optimized for 1.7 GHz and had a width of 4 mm. The overall length of the individual waveguides was kept at their initial value of 800 mm although the antenna itself did actually not require this much. It turned out that the simple theoretical estimation fails but not dramatically as the predicted probe position was in error only by about 5 mm or the optimum frequency by 40 MHz. The existence of the second, quite reasonable, shorter operating configuration, however, is not stated by the theory.

In order to give the discussion some depth in the frequency domain we performed sample measurements at 10 to 15 GHz, both with a conventional rectangular 19-dBi pyramidal horn antenna and with its corrugated counterpart. The main attempt was to try and find out if the theoretical or measured results are extendable in a simple way to completely different frequencies and if so, what is the preferred way to go. Both designs had been earlier developed for separate projects but did share some common features. They had a similar

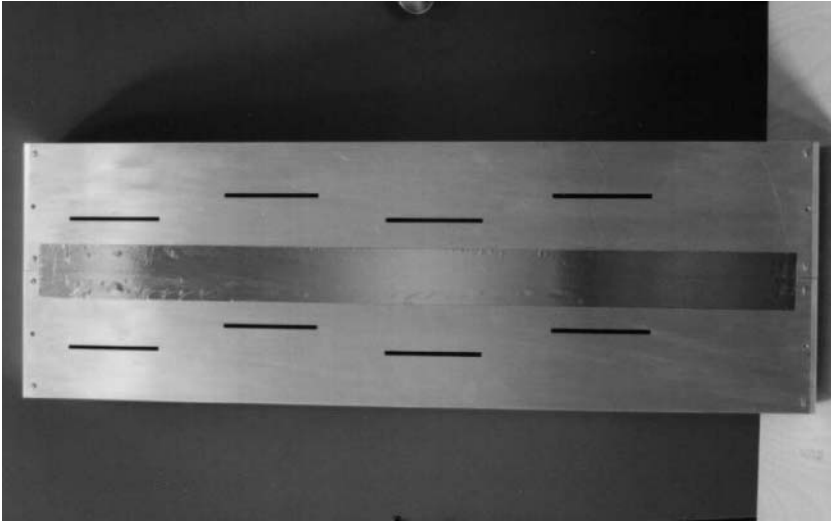

Figure 17.3 An S-band slot antenna, dimensioned for 1.7 GHz was used as an alternate test object because a direct coax/waveguide feed could be applied. Here, two subarrays are shown side by side for pattern measurements.

probe feed and a short position based on the quarter wave idea of (17.1), which provided the best impedance match for the specific application.

Scaling of mechanical dimensions as a function of operating frequency, wavelength, or impedance, for example, is sometimes a good tool for creating new microwave components. Here it seems to fail because neither of the two perhaps most obvious scaling variables, the guide wavelength and the impedance, gives a solid basis for comparisons when speaking about devices operating near guide cutoff. The best conversion “fit” was obtained when the S-band measurements and dimensions at 2 GHz were extrapolated to dimensions in the smaller horn at 12 GHz, based on an equal λ_g/λ_0 ratio, but here, too, the calculated input resistance at 12 GHz had an offset of almost 30%.

17.4 Analyzing the Effects of Mechanical Defects on the Performance of Small Phased Array Antennas

Communication and radar systems [9] make use of phased array antennas [7], which provide a way of steering the radiation pattern towards wanted directions or creating deep minima against unwanted regions [10]. Although

complex designs have been recently introduced, it is still customary to assemble a phased array antenna from a number of identical subarrays, which in turn can be just a row of equally spaced simple elements. For the purposes of the evaluation, a two-dimensional patch construction from [11] and [12] is shown in Figure 17.4. The element size is 40 mm by 40 mm and its height above the ground plane can be from 10 to 15 mm, depending on tuning desires.

Subarrays can have a fixed excitation or they too can be phase steered [13]. We consider here only the simple one-dimensional case, the pattern of which is

$$F(\theta) = \sum_{i=0}^{N-1} G_i(\theta) U_i e^{j(\phi_i + ikd_i \sin(\theta))} \quad (17.2)$$

where U_i is the element's voltage, d_i is the mechanical spacing, ϕ_i is the electrical phase shift of an element, and θ the angle of observation (measured

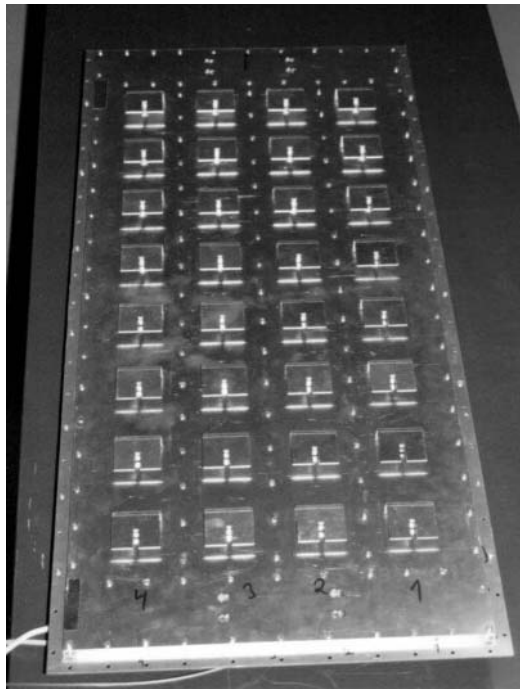

Figure 17.4 A 32-element, planar aluminum patch array for UMTS.

from the normal of the element plane). The individual element's own radiation characteristics are given by its pattern $G_i(\theta)$ and factor k is the common propagation constant. The total number of elements in the summation (N) is typically 2 to 10,000. Our prototype uses 32 identical elements formed as four subarrays. A considerable change in the computational task, generated by (17.2), happens if the phasings and gains are simultaneously functions of gain and phase, respectively, which yields

$$F(\theta) = \sum_{i=0}^{N-1} G_i(\theta, \phi_i) U_i e^{j(\phi_i(U_i) + ikd_i \sin(\theta))} \quad (17.3)$$

Now we see, for example, that the element gain depends both on its radiating direction (pattern gain) and on the phase change caused by the nonideal electronics. Most of the parameters in (17.2) and (17.3) are of mechanical origin and thus based on dimensions, shapes, and materials. We will next discuss examples particularly from the approach of mechanical manufacturing.

The construction has either welded or bolted joints between sheet metal or machined parts. Because of weight reduction, sturdy machined parts are generally not attractive, nor is steel. Equation (17.3) assumes a constant spacing between various radiating elements and subarrays and, although not explicitly shown, requires that a full symmetry exists along the main axes of the assembly. Thermal deformations during welding, as shown in [7], and the often careless handling of sheet metal parts tend to cause bends, kinks and misalignments, which disturb the symmetry and notably alter the interelement or intersubarray spacing [10]. Errors up to several millimeters were observed along each three coordinate axes for a maximum antenna dimension of 1m or so. This indicates that most, but not all, of the problems impair the phase characteristics of the antenna.

In the simple case of one mechanical fault, the phase error can be estimated as

$$\Delta\phi = 2\pi \frac{\Delta z}{\lambda} \quad (17.4)$$

in which Δz is the radial positioning error due to, for example, assembly tolerances as measured from the point of observation, and λ is the free space wavelength. The obvious result is a deterioration of the radiation pattern, which will also no longer be symmetrical as can be seen in Figure 17.5. Not

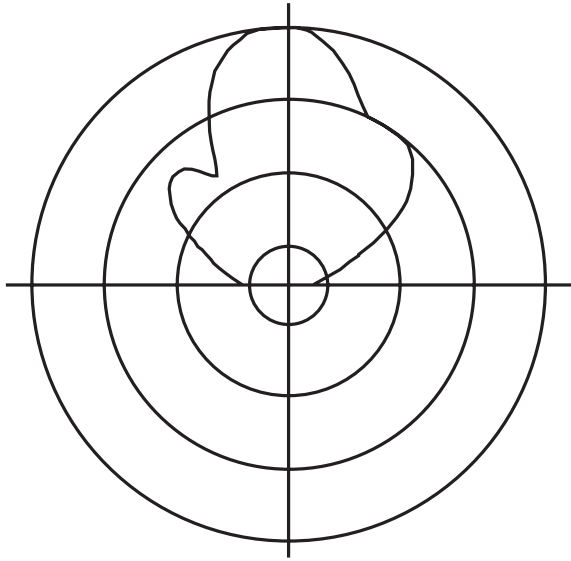

Figure 17.5 Errors in the mechanical lay-out and deviations from a coplanar assembly spoil radiation patterns. There is a 3-mm mounting error of a subarray.

only is the position of individual elements crucial, but the alignment of every tiny radiating stub is as well.

If a sharp pattern minimum is desired, the phasing error $\Delta\phi$ from (17.4) will in the case of two identical planar subarrays cause a filling of it up to a level of

$$L = 20^{10} \log \left(\sin \left(\frac{\Delta\phi}{2} \right) \right) \quad (17.5)$$

in decibels which is readily obtained from geometry. In practice, a dephasing of only 11° reduces the minima to be not deeper than -20 dB. Normally the design value is 40 dB or more, which indicates allowed mechanical uncertainties below 0.5 mm. When all details are considered, however, the real phase errors between subarrays can be many times larger than this, which is illustrated in Figure 17.6.

The unwanted coupling between adjacent subarrays inside the antenna electronics is mainly caused by poor power combiners. Our choice of carefully balanced ring hybrids, see Figure 17.7, seems to be attractive. When optimized, the construction provides 50-dB isolation between all feeding

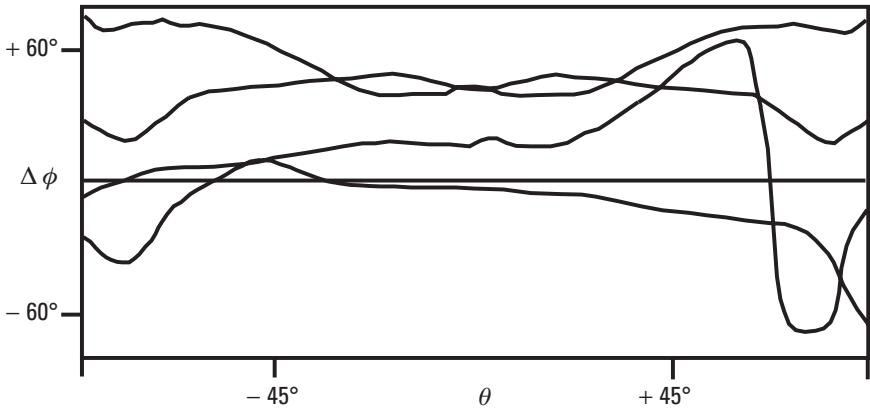

Figure 17.6 Measured phase patterns of individual subarrays clearly indicate mounting and manufacturing errors, which cause varying phase shifts.

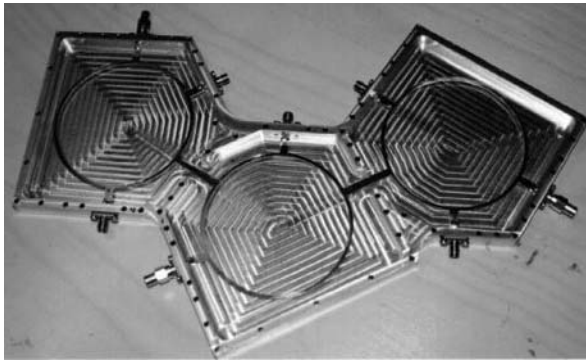

Figure 17.7 A triple hybrid ring power combiner used to feed the subarrays.

amplifiers although normal hybrids give about 20 to 25 dB only. A measurement result of our prototype compared to a commercial power divider is shown in Figure 17.8.

When two subarrays are brought to opposite phase with each other, the depth of the minimum in decibels can be estimated as

$$L = 20^{10} \log \frac{1 - 10^{-\frac{A}{20}}}{1 + 10^{-\frac{A}{20}}} \quad (17.6)$$

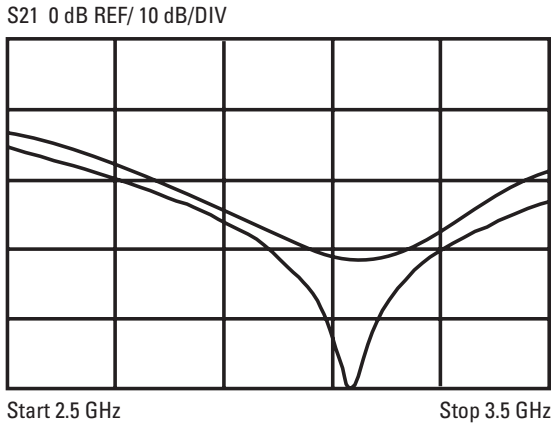

Figure 17.8 A normal ring hybrid provides just 20- to 25-dB isolation. Here, due to careful dimensioning and tuning, over 50-dB isolation between adjacent feeding ports was measured. The upper curve demonstrates a typical “off-the-floor” result.

where A is the difference in the feeding amplitudes of the two arrays in dB. Already a bias of 1 dB prevents us from getting more than 25 dB of interference rejection. The effect is clarified in Figure 17.9, where a wanted 30-dB minimum hardly goes to 10 dB.

This error type can be corrected in the software if more subarrays are used, because we do not need the smallest resultant value. Another interesting thing is the loss of effective gain. Also the axis of symmetry is changed when one of the subarrays is switched off. This indicates a severe bending of the ground plane outer edge.

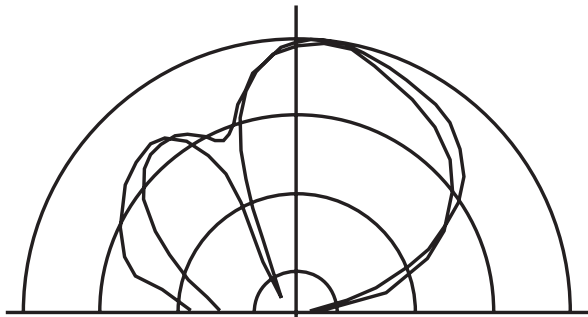

Figure 17.9 The measured pattern does not reach the minimum because there was a 2-dB amplitude unbalance in the feeding microstrip mountings. Scale 10 dB/div.

References

- [1] Helme, B., "Passive Intermodulation of ICT Components," *Proc. IEE Colloquium on Screening Effectiveness Measurements* (Ref. No. 1998/452), pp. 1/1–1/8.
- [2] Golikov, V., et al., "A Passive Intermodulation Phenomenon in Base Station Antenna Design for Mobile Networks," *Proc. URSI/IEEE Convention on Radio Science*, Sept. 2000, Helsinki, Finland, pp. 92–93.
- [3] Eskelinen, H., and P. Eskelinen, "Weldability Analysis Guides the Joining Process in Microwave Mechanics," *Proc. JOM-9 Conf.*, May 1999, Birkeröd, Denmark, pp. 157–163
- [4] Collin, R., *Foundations for Microwave Engineering*, 2nd edition, New York: McGraw Hill 1992.
- [5] Collin, R., *Theory of Guided Waves*, New York: McGraw Hill, 1990.
- [6] Johnson, R., *Antenna Engineering Handbook*, New York: McGraw Hill, 1993.
- [7] Eskelinen, H., and P. Eskelinen, "Assembly Considerations of High Power Wide-Band Patch Antenna Arrays," *Proc. AP 2000*, paper 0026, Davos, Switzerland, Apr. 9–14 2000.
- [8] Eskelinen, P., H. Eskelinen, and K. Tiihonen, "A Prototype of an Adaptive Integrated Antenna System for Cellular Networks," *Proc. ECWT'99*, Munchen, Germany, Oct. 1999, pp. 87–90.
- [9] Brown, L., *A Radar History of World War II*, Bristol, England: Institute of Physics Publishing 1999.
- [10] Hoek, C., "Uplink and Downlink Field Trial with a GSM/DCS1800 Smart Antenna Base Station," *Proc. European Wireless '99*, Munchen, Germany, pp. 113–118.
- [11] Eskelinen, P., et al., "An Innovative Combination of Software and Microwave Mechanics for High Performance Adaptive Antennas," *Proc. ECWT 2000*, Paris, France, pp. 196–199.
- [12] Eskelinen, H., P. Eskelinen, and K. Tiihonen, "Novel DFMA-Tools for Passive Microwave and RF Components in Cost-Effective Mass Production," *Proc. EuMW 2000*, Paris, France pp. 88–91.
- [13] Skolnik M., *Radar Handbook*, 2nd edition, New York: McGraw-Hill 1990.

18

Summary

The first chapters of this book have emphasized the fact that in order to be able to analyze the behavior of a mechanical microwave component and to find the requirements for its manufacturing, the designer must have enough knowledge about electromagnetic wave propagation, transmission line theory and electromagnetic properties of common construction materials. In addition to this we have pointed out that the application of modern design methods will increase the production yield, have a positive effect on microwave performance and even enable previously unobtainable features. Finally we have shown that without a good knowledge about various mathematical tools it is almost useless to start searching any means to improve the characteristics of a mechanical microwave component or try to solve the required Maxwell's equations for wave propagation.

To improve the effectiveness of traditional engineering design methodologies we have suggested the use of an advanced scheme, which consists of six basic elements: (1) advanced requirement lists throughout the design process, (2) teamwork between experts of microwave engineering and mechanical engineering (3) avoidance of useless redesign cycles, (4) use of tuned questionnaires, (5) utilization of a computer-aided environment, and (6) use of a specialized DFMA-optimization approach for microwave mechanics. It is also important to understand the overall structure of the microwave design process inside the computer-aided environment, which is supported with appropriately specified CAD applications. This environment can be described in a form of a design "chain," which includes the

computer-aided manufacturing data, the performance simulation results of the microwave device, modern hypermedia links, and VE applications.

This book has shown through several examples that material selection is always a compromise between electrical and mechanical properties. We have made an attempt to correct a common mistake of many microwave textbooks in which a misleading impression about the superiority of plating or coating of the base material is usually given. We have pointed out that from the mechanics point of view it is insufficient to select only the appropriate material type. The exact material identification should be established instead. We must also understand that plating itself never can replace a careful base material alloy analysis even though the coating is properly selected.

From the wide branch of technical documentation it is important to emphasize three areas, which differ significantly from traditional documentation practices. According to our opinion these areas are: (1) effects to traditional parametric modeling, (2) difficulties to apply general rules of design for manufacturability and assembly, and (3) restrictions in utilizing general tolerances.

Throughout this book we have tried to follow, as closely as possible, the guidelines of cost-effective design and manufacturing of microwave components. We have discussed three main aspects to explain the high product prices: (1) many microwave applications include difficult geometries or materials for traditional manufacturing processes to handle, (2) passive microwave devices utilize several precious and expensive materials, and (3) microwave applications need specialized tooling and fixturing systems and quite tight dimensional tolerances. To help the designer decrease the total costs of a microwave product we have suggested the derivation of mathematical ratios to estimate the cost-effectiveness of a design process. Some practical guidelines for quality oriented microwave design have been shown as well. Much of the final electromagnetic characteristics in passive microwave components are defined by their physical dimensions and shapes. Hermeticity tests for encapsulating electronics form a very specific area. Fortunately there are good international standards to guide this quality enhancement process. Finally, to illustrate the overall picture of the mechanical design task in a microwave environment we have also added some examples from antenna constructions and industrial measurement systems. They highlight the importance of a total structural design and the needs for establishing environmental loading as well.

Many manufacturability problems in microwave mechanics have been discussed. We have shown practical solutions for weldability, machinability, and other problems by using industrial examples. However, in the welding

industry, for example, it has proved to be difficult to accept the fact that, to be able to fully utilize the specialized joining instructions for welded microwave components or constructions, it is necessary to understand some basic rules of microwave technology and the theory of microwave propagation. Typically, the initial material selection is made according to the performance requirements of the designed radio frequency construction. After this the weldability aspects (both material properties and constructional aspects) can be taken into account. Through all the case examples we have presented several manufacturing or assembly technologies to emphasize the importance of exact comparisons between possible alternatives. We have seen that usually designers tend to select the first idea coming into their mind and a comparison is typically forgotten. For example in addition to welded and soldered joints many microwave applications still need screw joints to enable a later opening of the device. In our book we have not presented manufacturing technologies just in a form of a list of possibilities for each geometry but instead of that we have tried to find the reasoning from the required performance and accuracy level. For many microwave devices, for example, high-speed machining or ultra-precision machining is mandatory. In many cases, the specified geometry of the workpiece gives limited possibilities to use standardized tools for manufacturing. Most quality errors in the production of mechanical microwave parts are caused by machining forces. This sets special requirements for material selection and fastening systems. We do wish that these examples could make the reader understand the differences between “traditional manufacturing technology” and “manufacturing technology for microwave mechanics.”

As shown earlier, the performance of a mechanical microwave product is always a compromise due to different aspects of material selection, manufacturing accuracy, and of course the designed geometry. This fact does not, however, prevent attempts to find more optimized mechanical constructions. A high-power, low-loss microwave filter, which we have discussed in this book in several contexts, could be, for example, either of sheet metal stripline type or a milled construction. An alternative approach is to construct, for example, transmission lines from thin metal sheets whereby a considerable reduction of weight and cost is generally anticipated when compared to waveguides or milled designs. It is important, however, to make a full comparison within each process type as well—for example, CO₂- and Nd:YAG-lasers have significant differences in cutting quality. Sharp-edged geometries are usually manufactured with pulsed Nd:YAG-lasers. Even this individual example has been enough to show the importance of both rethinking the mechanical construction and also comparing the possibilities within a

selected manufacturing technology. Though we have mostly focused on novel microwave applications, we have also briefly discussed the most common industrial manufacturing technologies (e.g., extrusion and plating). In these cases, we desired to present means to improve the effectiveness of volume production. In addition to cost-related topics, we have also shown the importance of fitting together the mechanical properties of the plating material and the base material. To ensure the right coating properties, it is also extremely important to find the best application of each plating technology and alternative plating compositions—there are, for example, more than ten types of gold platings from which the final selection can be made.

To support the principle of a cross-technological approach, we found it reasonable to include some basic information about measurement equipment as well. A passive mechanical microwave component or its prototype should be measured both with mechanical test methods and through selected electrical processes whenever possible. This not only increases the reliability of the obtained results but also enhances the level of knowledge. A vector network analyzer is one of the key devices for the evaluation of passive microwave components despite its price and operational complexities. A thorough understanding of the Smith chart and the four complex scattering parameters is vital for efficient use of this instrument. Quite often, it is possible to rely on mechanical dimensions and material data only. This is particularly true if one prototype construction has been documented and electrically measured, and following samples are referred to the original through their three-dimensional physical sizes. Special care is needed if the design includes curved corners or edges or if there is a risk of losing, for example, the parallel alignment of adjacent critical surfaces. Sometimes a mechanical measurement is not feasible at all after final assembly. For example, many microwave resonators should be completely closed volumes, so only an electrical test makes sense. Practical test set-ups often require a cooperative attitude between the original mechanics designer and the test engineer. Particularly tricky are those cases where a prototype has to be tested against its specification, but the connection of instrumentation requires some physical entrance (e.g., into an enclosure or a waveguide structure). In these cases, a skilled mechanics specialist is an invaluable person. Sometimes indirect tests are the only feasible option.

List of Acronyms

ABS	acrolonitrile butadiene styrene
ACAD	autoCAD [®] software
AFM	atomic force microscope
AGC	automatic gain control
AI	artificial intelligence
APC-7	A-type precision connector, 7-mm diameter
ASME	American Society of Mechanical Engineers
BPP	beam parameter product (of laser)
CAD	computer-aided design
CAE	computer-aided engineering
CAM	computer-aided manufacturing
CAP(P)	computer-aided process (planning)
CCD	circumscribing-circle diameter
CE	concurrent engineering
CE II	collaborative engineering

CIM	computer integrated manufacturing
CNC	(computer-based) numerical control
dB	decibel
dBi	decibels referred to an isotropic element
dBm	decibels referred to 1 mW
DC	direct current
DCS	digital communication system
DFA	design for assembly
DFEE	design to fit an existing environment
DFM	design for manufacturability
DFMA	design for manufacturability and assembly
DFX	design for X (X can represent several issues)
DMLS	direct metal laser sintering
DOE	design of experiments
DSM	design structure matrix
DUT	device under test
DXF	data exchange format
EDP	electrical data processing
EFTF	European Frequency and Time Forum
EM	electromagnetic (software)
EMC	electromagnetic compatibility
FAF	fast axial flow CO ₂ lasers
FCS	(International) Frequency Control Symposium
FEA	finite element analysis
FEM	finite element method
FEP	fluoroethylenepropylene

FET	field effect transistor
FIME	Federation of Finnish Metal, Engineering, and Electrotechnical Industries
F-number	F-number is used to describe the properties of focusing (in laser)
FS	full scale
GaAs	gallium arsenide
GT	group technology
HAZ	heat-affected zone
HS	hard steel
HSS	high-speed steel
IACS	international annealed copper standard
IC	integrated circuit (chip)
IEE	Institute of Electrical Engineers
IEEE	Institute of Electrical and Electronics Engineers
IF	intermediate frequency
IPCs	integrated passive components
IPD	integrated product development
IPT	integrated product team
IT	ISO tolerance grade
LCC	life cycle cost (analysis)
LNA	low-noise amplifier
LTCC	low-temperature cofired ceramics
MAG	metal active gas (welding)
MIG	metal inert gas (welding)
MIT	Massachusetts Institute of Technology
MMIC	microwave and millimeter wave integrated circuit

MoM	method of moments
MRA	multirepresentation architecture
P&D	planning and design activity
PC	polycarbonate
PCD	polycrystalized diamond (cutter)
PDA	planning and design approach
PDM	product data management
PDMS	product data management system
PE	polyethylene
PEEK	polyether-etherketone
PFA	perfluoralkoxy
PIM	passive intermodulation
PIND	particle impact noise detection
PPO	polyphenylene oxide
PTFE	polytetra fluoride ethylene (commercially Teflon [®])
PUR	polyurethane
PVC	polyvinyl chloride
QA	quality assurance
QC	quality control
QFD	quality function deployment
R&P	rapid prototyping (RP)
RAM	random access memory
RCS	radar cross section
RE	reverse engineering
RF	radio frequency
RMA	mildly activated (soldering) flux

RTC	relative temperature coefficient)
RX	receiver unit
SAF	slow axial flow (CO ₂ lasers)
SE	simultaneous engineering
SF	slow flow (lasers)
SFF	solid free-form fabrication
SLS	selective laser sintering
SMA	subminiature A connector
SMD	surface mounted device
SPC	statistical process control
STL	stereo lithography (file format)
SWR	standing wave ratio
TDMLP	tuned design methodology for laser processing
TE	transverse electric
TEM _{piq}	transverse electromagnetic mode pattern
TF	transverse flow (lasers)
TIG	tungsten inert gas (welding)
TMF	metal electroless forming
TOLP	tuned optimising algorithm for laser processing
TP _{pi}	transverse electric field pattern
TQC	total quality control
TQCM	total quality control management
TR	transmit-receive unit
TX	transmitter unit
UMTS	universal mobile telecommunication system
USW	ultrasonic welding

UV	ultraviolet radiation
VA	value analysis
VDI	Verein Deutscher Ingenieure
VE	virtual engineering
VM	virtual manufacturing
VNA	vector network analyzer
VR	virtual reality
WBS	work breakdown structures
WG	waveguide (dimensional classification number)
WPS	welding procedure specification
WWW	World Wide Web
YIG	yttrium-iron-garnet (resonator)

List of Symbols

- $A(r)$ Antenna pattern function's vector potential
- a Waveguide cross section width
- a_p Depth of cut (in machining)
- a_0 Constant portion of total costs not depending of the product or production type
- $a_1 \dots a_3$ Coefficient describing the percentage portion of the total costs of the original product
- B Magnetic flux density
- b Waveguide cross-section height
- c Propagation speed of the wave
- D Electric flux density
- d_i Mechanical spacing
- E Electric field intensity
- E_y Electric field directed along the y -axis
- $F(\theta)$ Array pattern vector
- f Frequency

- f_c Cut-off frequency (of a waveguide)
 f_z Feed (in machining)
 G Gain (of an electrical component)
 $G_i(\theta)$ Individual element's own radiation characteristics pattern
 g Distributed electrical parameter
 H Magnetic field intensity
 \bar{I} Current vector
 i Integer
 J Current density
 $\mathcal{J}(r)$ Current density vector
 k Propagation constant
 Ku Microwave frequency band (12 to 18 GHz)
 l Distributed electrical parameter
 m Integer
 n Integer
 Q Quality factor (of a resonator)
 r Distributed electrical parameter
 r The coordinate at which the field pattern is to be calculated
 (r') Integrand
 S Microwave frequency band (2.6 to 4 GHz)
 $S_{11}, S_{12}, S_{21}, S_{22}$ Scattering parameters
 t Time
 \bar{U} Voltage vector
 U_i Element's voltage
 v_c Cutting speed
 X Reactance

- $x_3 \dots x_1$ Exponent describing the importance of cost portions
- Z Complex impedance
- Z_w Characteristic impedance
- Z_A Characteristic impedance for section A (of a waveguide)
- Z_B Characteristic impedance for section B (of a waveguide)
- Z_{in} Input impedance
- \bar{Z}_0 Impedance of the transmission line
- \bar{Z}_b Virtual impedance
- z Distance along the tube's main axis
- α Attenuation constant
- β_c Wave's transversal phase constant
- β_0 Wave's phase constant
- β_{ox} Wave's transverse phase coefficient
- β_{or} Normalized free space phase constant
- $\bar{\gamma}$ Propagation constant of the line $\left(= \sqrt{\bar{Z}\bar{Y}} \right)$
- δ Penetration depth (of a microwave signal)
- \mathcal{E} Complex permittivity
- ε Permittivity
- ε_r Relative permittivity
- $\varepsilon(t)$ Step function
- ε_o Permittivity of vacuum $\varepsilon_o = 8.854 \cdot 10^{-12}$ F/m
- ε' Real part of complex permittivity
- ε'' Imaginary part of complex permittivity
- ϕ Angular position
- ϕ Diameter
- ϕ_i Electrical phase shift of an element

$\Delta\phi$ Phase difference

λ Wavelength (of a microwave signal)

λ_0 Free space wavelength

μ Permeability

μ_r Relative permeability

μ_0 Permeability of vacuum

ρ Reflection coefficient

ρ Charge density

$\bar{\rho}$ Voltage reflection coefficient

ρ Resistivity

σ Conductivity

σ_r Relative conductivity

$\sqrt{\bar{Z}\bar{Y}}$ Characteristic impedance of the transmission line

θ Angle of observation

ω Angular frequency

φ_z Ratio between the new and original number of products to be manufactured

φ_D Scale factor describing the dimensional changes according to the similarity laws, derived from the change of the operating frequency of the device

φ_{PC} Scale factor for the production costs compared with the original product

∇ Del operand

Requirements for Viewing Appendixes A, B, and C

Appendixes A, B, and C are available on the attached CD-ROM. In order to fully utilize the stored materials, the following software requirements should be met:

- Power Point-98 (or any later version);
- AutoCAD14 with Genius Desktop facilities (or any later version);
- Word-98 (or any later version).

The minimum hardware requirements are as follows:

- 40 MB of free disk space;
- Pentium II 400-MHz Processor;
- High-color, high-resolution monitor (resolution 1024×768);
- 3-D Diamond Fire GL 1000 8 Mt AGP graphics card;
- A2-sized color printer.

All the illustrative figures and additional tables are presented with a Power Point slide show. Manufacturing documents and 3-D models are saved in dwg format and they can be opened properly only with the Genius Desktop

facilities. The list of manufacturing documents in each subfolder is collected in a printable Word document.

The content of each appendix is classified into folders and their subfolders according to Figure A.1.

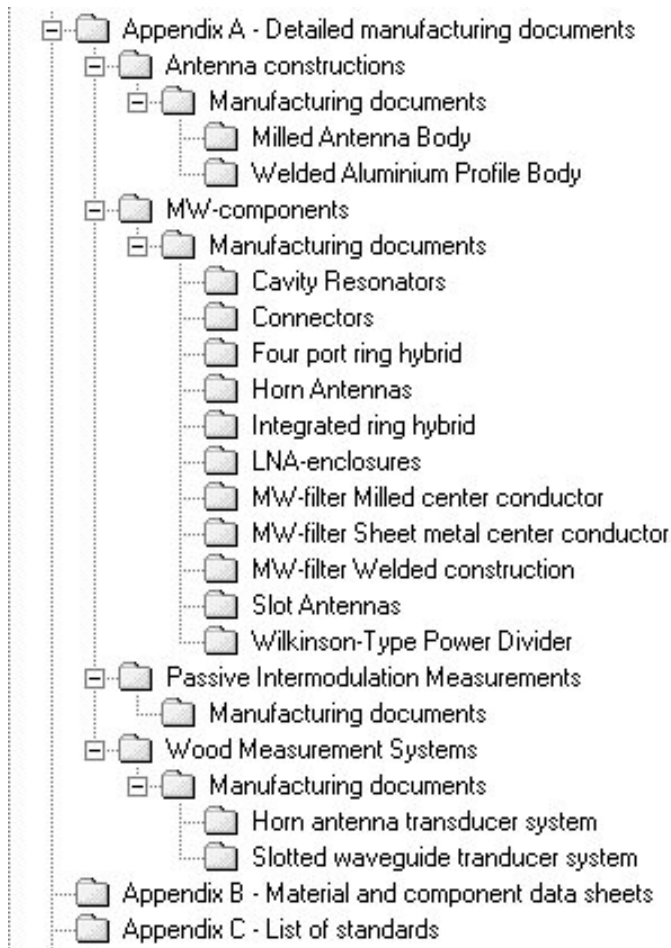

Figure A.1 Folders and subfolders in each appendix.

About the Authors

Harri Eskelinen is a senior research scientist in the Laboratory of Manufacturing Technology at Lappeenranta University of Technology, Finland. He received his M.Sc. (1987) and Dr. Sc. (mechanical engineering) (1999) from Lappeenranta University of Technology. Before his current position, he was a senior lecturer of manufacturing technology in the Laboratory of Steel Constructions at Lappeenranta University of Technology. Prior to his university career, Dr. Eskelinen worked for 5 years as a design engineer in Finnish industry. Even then, one of his initial tasks was related to the documentation management of broadcasting antenna installations and to the vibration problems in 300-m antenna towers due to icing. He has also been a project manager in several large industrial and military research projects that were focused on mechanical microwave devices. During the last few years, Dr. Eskelinen has published several conference papers and reviewed journal articles about new design methodologies and related manufacturability aspects in the field of microwave mechanics. Dr. Eskelinen is an observer member in the International Institute of Welding (IIW) and was in charge of organizing the 7th NOLAMP and ICEWIA conferences in 1999. His areas of expertise include design for manufacturing and assembly (DFMA) and laser processed microwave components.

Pekka Eskelinen is a professor in the radio laboratory and the head of the Institute of Digital Communications at the Helsinki University of Technology, Finland. He has recently left his position as the head of the Electronics

and Information Technology Department at the Finnish Defense Forces' Technical Research Center. Before that, he was the head of the Microwave Laboratory and a professor of electronics at Lappeenranta University of Technology. He received his M.Sc. (1979) and Dr. Sc. (electrical engineering) (1992) from the Helsinki University of Technology. He worked for 5 years at the Technical Research Center of Finland, designing subsystems for satellite ground stations and military radar equipment. In 1984, Professor Eskelinen joined the National Board of Aviation, where he was chief of the avionics section. Since 1988, he has been involved in accident investigation and is a technical expert in the planning commission for investigation of major accidents. Professor Eskelinen has also been a member of the board of governors in the IEEE Aerospace and Electronic Systems Society, and continues as an associate editor of the *IEEE AES Systems Magazine* and as a member in the Scientific Committee of the European Frequency and Time Forum, Switzerland. Professor Eskelinen has been nominated to join the International Advisory Committee of the International Joining of Materials (JOM) Institute and has gained a docent's status of radio frequency engineering both at Lappeenranta University of Technology and at the Tampere University of Technology. He is also a member of the communications section in the National Scientific Advisory Council for Defense and has been a representative of Finland in the Western European Armament Group's Panel 6.

Index

- Abrasive wear, 316
- Acrylonitrile butadiene styrene, 265
- Across wind component, 298
- Acrylic-based adhesive, 205–6
- Active microwave component, 127, 243, 253, 256, 322
- Adhesive wear, 316
- Advanced methodology, 34–42
- Aerodynamic damping, 299–300
- Aeroelastic effects, 299
- Aging, plastics, 53
- Air dielectric, 25, 178, 243
- Air gap, 231
- Alloy composition, 50–51
- Along wind component, 298
- ALUMEC, 61–62, 166, 167, 218, 222
- Alumina insulator, 69
- Aluminum, 19, 45, 46, 49, 50, 51, 70–71, 72, 93, 127, 164, 165, 180, 185, 186, 193, 229, 253, 261, 280, 281, 282
- Aluminum alloy, 60–62, 168, 169, 222, 248
- Aluminum feeding strip, 249
- Aluminum nitride, 70, 72, 73, 74
- Aluminum nitride-silicon carbide, 70
- Aluminum oxide, 70, 273
- Aluminum oxide-silicon carbide, 70
- Annealing, 222, 267, 275
- Anode, 272
- Antenna constructions
 - basics, 295–97
 - dielectric material, 46–47
 - plating, 282
 - sheet metal forming, 267–68
 - wind/ice loads, 297–300
- Antenna location, 144
- Antenna shape, 3
- Application profile, 27
- Arc welding, 154, 155, 180
- Artificial intelligence, 80, 83
- ASCE 7 standard, 297
- Assisting tools, systematic design, 31–33
- Atomic force microscope, 313–14
- Attenuation, 157, 158, 253, 288, 290, 322, 328
- AutoCAD, 81, 97, 125
- Automated infrastructure support, 131
- Automatic gain control, 289
- Automation, welding, 156
- Background vortex effect, 299

- Band-reject filter, 328
- Barometric pressure, 52
- Beam laser, 257
- Beam microwelding, 156
- Beam parameter product, 138, 157
- Beam parameters, 156–57
- Beam propagation factor, 157
- Beam quality optimization, 146–47
- Beam steering, 231
- Beam welding, 154, 155, 161, 193–97
- Bending processes, 267–68
- Beryllium copper, 56–57, 58, 127, 158, 164–70, 171, 281
- Beryllium oxide, 72, 73
- Beryllium oxide-silicon carbide, 70
- Bimetal resonator, 281
- Bismuth alloy, 222
- Blending, powder metallurgy, 68
- Blow molding, 266
- Bolted joint, 180
- Boolean logic, 128
- Bore bit, 215
- Boron carbide, 70
- Boundary conditions, 157
- Brainstorming, 30, 32
- Brass, 45, 51, 58, 193, 234, 253, 281
- Brinell hardness test, 317
- Bronze, 51, 273
- Butterworth filter, 157–58, 255–56
- Butt weld, 176

- Cable component, 55
- Cable quality, 321, 325
- Capacitor, 75
- Capillary, 155
- Carbon-reinforced plastic, 66
- Cassegrain antenna, 296
- Casting, 117, 134, 142, 174, 264, 265, 311
- Cathode, 272
- Cavity filter, 281
- Cavity-initiated electromagnetic wave, 22–26
- Cavity resonator, 113, 154, 161, 175, 238–39
 - joint geometries, 170–77
- Cavity weldability, 153
- Center conductor, 239–40, 246, 247–48, 251–52
- Center pin, 164–66, 167, 170, 214, 274
- Ceramic materials, 66–77, 209, 272, 273
- Ceramic microwave element, 69–70
- Ceramic packaging, 195
- Chamfered boundaries, 215, 219
- Characteristic impedance, 10, 13, 18
- Checklist, 31
- Chemical wear, 315–16
- Chip formation, 212, 213
- Chromate coating, 279, 280
- Chrome plating, 281
- Chromium alloy, 275
- Circuit board plating, 279–80
- Circularity, 307–8, 309
- Circumscribing circle diameter, 262, 263
- Cleaning requirement, 214
- Clinching, 180
- Closed geometries, 214
- CO₂ laser, 156, 158, 159–60, 161, 164, 180–81, 251–52, 341
- Coated microwave components, 278–82
- Coating materials, 273–78
- Coating quality, 273
- Coating technology, 271–73
- Coaxial cable coupling, 23
- Coaxial connector, 26, 164–65, 171, 182, 214, 230, 256–58, 274, 330–32
- Coaxial extrusion, 261, 262
- Coaxial filter, 239–40
- Coaxial rotary joint, 231, 233, 235
- Cofired ceramics, 75–77
- Cold extrusion, 261, 262
- Cold forming, 174, 264
- Cold pressed enclosure, 174
- Collaborative concurrent design, 133
- Compaction, powder metallurgy, 68
- Complex permittivity, 45–46
- Compressing tools, 167
- Compression molding, 264, 265
- Computer-aided design, 38, 39, 42, 79–80, 88, 89, 91, 95, 125, 128, 129–30, 133, 134, 139, 140, 146, 339
 - integration problems, 102–8
 - tools integration, 80–96
- Computer-aided design for manufacturability, 124–25

- Computer-aided engineering, 42, 81, 82,
85, 89, 125, 146
integration, 94–96
- Computer-aided manufacturing, 42,
84–85, 95, 125, 340
- Computer-aided process planning, 85
- Computer-based numerical control, 139,
140, 211, 237
- Conceptualization, 30, 133
- Concurrent engineering, 131–34, 142
- Conductive adhesive, 193, 206–8
- Conductive coating, 45–46
- Conductive glue, 185–86
- Conductivity, 45, 52, 54, 153, 173
good, 17–19
value analysis, 50–51
with permittivity, 16
- Conical geometry, 214, 215
- Connection philosophies, 26–27
- Connector bodies, 58
- Connector components, 55, 57, 58, 321,
325
- Connector mounting, 229–31
- Connector pin, 161–62, 164–66, 167
- Contact component, 278–79
- Contacting rotary joint, 235
- Contact pin, 58
- Contact socket, 57
- Convergent thought method, 32
- Copper, 18, 19, 45, 46, 49, 50, 51, 52,
55–56, 127, 222, 261, 269, 272,
273, 275, 281
- Copper beryllium, 164–70, 171, 214
- Copper plating, 279, 280
- Copper-tin-zinc alloy, 276
- Corrosion, 53, 144, 155, 159, 168, 169,
204, 314, 315, 328
- Corrugated waveguide electroforming,
268–69
- Cost accumulation, laser processing,
136–41
- Cost analysis, 42
metallic components, 55
production, 119–21
- Counter-nut connector, 230
- Coupling, 3, 23, 164, 187–88, 243, 247,
288, 329
- Crater, 311
- Creative design, 32
- Cross-flow laser, 156
- Cross-technological approach, 91, 124,
129–31, 161, 342
- Curved resonator root, 216
- Cut-bend-weld system, 250
- Cut-off frequency, 23, 24, 25
- Cut-off point, 313
- Cutting
laser process, 250–51
in general, 211, 243–46
- Cyanoacrylate-based adhesive, 206
- Cylindricity, 307, 308
- Damping, 228, 299, 300
- Data exchange format, 99, 125
- Datum, 304–10
- Deep drawing process, 267, 268
- Delphi method, 30, 32
- Demands list, 33
- Design catalogue, 33
- Design costs, 119–20
- Design for function, 32
- Design for manufacturability, 29, 122–29
- Design for manufacturability and assembly,
29, 90, 95, 111, 123–24, 127,
339
versus performance-oriented approach,
114–16
- Design group expertise, 33
- Design guidelines, basic, 45–47
- Designing and manufacturing, barrier
between, 123–25
- Design process, concurrent engineering,
131, 132–33
- Detail design phase, 30
- Deutsche Industrie Norm 69910, 31
- Device under test, 99
- Diameter symbol, 308–9
- Diamond-wheel grinding, 69
- Die costs, 141
- Dielectric constant, 46
- Dielectric material selection, 45–47
- Diffraction theory, 99
- Dimensional accuracies, 135, 213, 228–29,
240

- Dimensional tolerances, 122, 134, 180–81
- Dimensional uncertainties, 8–15, 244
 - measuring, 303–10
- Dimensions optimization, 144
- DIN standardization, 117
- Diode laser, 156
- Dipole antenna, 296
- Dipping, 275
- Direct current excitation, 156, 250
- Direct current micro-ohm meter, 184
- Direct extrusion, 261
- Divergent thought method, 31
- Documentation, 111–12, 117
- Doping, 272
- Double-tolerancing, 215, 219–20
- Drawing processes, 142, 266–67, 268
- Drilling, 211, 214
- Dual channel rotary joint, 235, 236
- Ductility, 55, 261, 262
- Duroid, 46
- Durometer, 317
- DWG file import, 81

- Eddy-current inspection, 312
- Edge-flanged joint, 176
- EditFEKO, 99, 100
- Eight-level optimization approach, 38
- Electrical-discharge machining, 69
- Electric field, 7, 8, 13, 20, 24
- Electric rod waveguide, 257
- Electroforming, 268–69, 272, 273
- Electroless nickel, 279
- Electroless plating, 268, 272–73
- Electrolytic treatment, 275
- Electromagnetic capability, 196
- Electromagnetic compatibility, 46, 102
- Electromagnetic loss, 16–17, 47–48
- Electromagnetic radiation, 19–22
- Electromagnetic wave, 22–26
- Electronic data processing, 79
- Electronics, 129–30, 144
- Electroplating, 272, 275
- Elliptical waveguide, 26
- Embodiment design phase, 30
- EN 13920 standard, 192
- EN 22768 standard, 310
- Encapsulating electronics, 153
 - enclosures, 224–29
 - welding, 192–99
- Enclosure design
 - encapsulating electronics, 224–29
 - shielding, 329–30
 - testing, 317–18
 - welding, 192–99
- Environmental degradation, 53, 54
- Environmental requirements, 130, 161
- E-plane, 20
- Epoxy adhesive, 166, 208
- Equipment costs, 146–47
- Ergonomics, 130
- Etching process, 168, 169
- Eurocode 1, 297
- Euronorm, 117
- Europe, 204–5
- European Union, 45–46
- Evaluation, 82
- Evaluation phase, 32
- Explosive forming, 267
- Extended dielectric connector, 230
- Extension length, horn, 21
- Extrusion processes, 142, 261–64

- Factor analysis, 146
- Far field, 6, 7, 20
- Fast axial flow laser, 156, 250
- Fastener system, 129
- Fatigue wear, 316
- Feature-based system, 84, 85
- Feeding network, stripline, 249
- Feeding strip, laser-processed, 249–56
- Feed-probe connection, 93
- FEKO software, 96, 99–102
- Fiber-glass plastic, 66
- Fillet weld, 159, 176
- Filter constructions, 178, 243
 - cavity filter, 281
 - laser-welded stripline, 157–64
 - low-loss interdigital, 253–56
 - manufacturing, 159–64
 - tubular coaxial, 239–40
 - ultrasonic welding, 164–70
- Filter input impedance, 159, 160
- Fine cutting, 250
- Fine leak testing, 318

- Finishing, 68–69, 211
Finite element analysis, 81, 82, 86, 88, 89
Fittings applications, 209–10
Fixturing system, 129, 137, 139, 167,
186–87
Flame cutting, 250
Flange, 26
Flange-mount connector, 231
Flatness requirement, 306–7, 309
Flexible waveguide, 280
Flow chart, 39–42, 85
Fluid impregnation, 69
Fluoroethylenepropylene, 65, 67
Fluorine plastics, 65
Flutter, 299
Flux, sealing, 194
F-number, 157
Focusing, laser welding, 157
Forced vibration, 227
Forging processes, 142
Forming processes, sheet metal, 267–68
Fourier series expansion, 8
Four-port method, 180
Free space propagation, 5, 8
Frequency sweeping mode, 322, 323
Friction measurement, 315
Functional aspect, welded device, 90
Functional design, 126
Functional optimization, 144
Funnel phenomena, 263
Fusion cutting, 250
Fuzzification, 128
Fuzzy logic, 127–28, 129, 146

Gain, 21
Gallery method, 30, 32
Galloping, 299
Galvanic contact, 158
General wave propagation, 5–8
Geometrical tolerances, 112, 116–18, 187,
189
measuring, 304–10
Glued joint, 180, 205–9
Gold, 45, 45–46, 51, 269
Gold plating, 58, 127, 158, 164, 165, 167,
238, 273–74, 277, 278, 279,
280, 281

GraphFEKO, 99, 101
Green's function, 96
Grid antenna, 298
Gross leak testing, 318
Group technology, 132–33
Groupwork, 124, 129–31
Gust effect factor, 299
Gust loading factor, 298–99, 300

Handling system, 138
Hardness profile
joint, 168, 170
metallic component, 55
testing, 317
Heat-affected zone, 88, 156, 184, 250, 311
Heat input, 161, 166, 182, 185, 188–90,
197
Heat treatment, 93
Helium, 318
Helmholtz's wave equation, 6–7
Hermetic enclosure, 153, 159, 161, 257
testing, 317–18
High-Q filter, 113
High-Q whispering gallery mode resonator,
238–39, 303
High-speed machining, 211, 229, 341
High-temperature ceramic adhesive, 209
Holistic design, 133
Hollow shaft rotary joint, 235
Holography, 312
Horn, 21
Horn antenna, 289–91, 292–93, 296, 308,
331–32
Hot dipping, 272, 273
Hot extrusion, 261, 262
H-plane, 20–21
Human aspects, 132
Humidity, 52, 167, 318
Hydraulic precision forming, 280
Hydrostatic extrusion, 261–62
Hyperbolic functions, 12
Hypermedia applications, 86–94
Hypertext, 86

Ice load, 297, 299, 300
IE3D software, 96–98
Immersion process, 275
Impact extrusion, 261, 262

- Impact forging, 68
- Impedance, 157, 159, 160, 245
- Impedance matching, 15, 171, 257
- Impedance mismatch, 3
- Improvement process, 85
- Inclusion, 311
- Inductively supported laser welding, 155
- Inductor, 75
- Infiltration, powder metallurgy, 69
- Injection foam molding, 266
- Injection molding, 68, 264, 265–66
- Input impedance, 178, 180–81, 257, 330–32
- Input reflection coefficient, 196
- Insulation depth, 158
- Insulator, 65
- Integrated passive component, 75–76
- Integrated product development, 131
- Integrated product team, 127
- Integrated ring hybrid, 221
- Interdigital stripline filter, 253–56
- Interference fit, 209
- Intermodulation. *See* Passive intermodulation
- Internal cracking, 263, 264
- International Standardization Organization
 - DIS 4354 standard, 297
 - tolerance grades, 117, 210, 213, 237, 245, 305
 - 286-1 standard, 213
 - 286-2 standard, 166
 - 1101 standard, 309–310
 - 2768-2 standard, 310
 - 13920 specification, 192
- Internet, 85
- Invar, 62–64
- Investment costs, 137, 138, 140, 148
- Ion implantation, 272
- Iridite coating, 279
- Iron, 51
- Ishikawa's design approach, 31
- Isolation method, 222–23, 328
- Isostatic pressing, 68
- Joining
 - costs, 142
 - instructions, 153–54
 - technology, 93, 179
- Joint geometries, 146, 168, 170–77
- Joint reliability, 310
- Joint weldability, 153, 161–62
- Keyhole welding, 155
- Klystron, 27
- Knoop hardness test, 317
- Lacquer system, 275
- Laser cut sharp-edged center conductor, 251–52
- Laser cut stripline, 253–56
- Laser cutting, 250–51
- Laser cut-weld, 250
- Laser flame cutting, 250
- Laser fusion cutting, 250
- Laser hybrid welding, 155
- Laser processing
 - component costs, 136–41
 - equipment, 145
 - optimization, 141–48
- Laser sublimation cutting, 250
- Laser-welded covering, 159
- Laser-welded sealing, 193–97
- Laser-welded steel joining, 179
- Laser-welded stripline filter, 157–64
- Laser welding, 145, 154–56
 - joint geometries, 170–77
 - parameters, 156–57
 - quarter-wave antenna, 184–88
- Lateral extrusion, 262
- L-band patch element, 177–79, 185
- Lead component, 222, 261, 278–79
- Leak testing, 318
- Leasing costs, 138
- Life cycle analysis, 131
- Lifetime, product, 120–21, 147–48
- Line impedance, 12
- Liquid penetrant, 312
- Loaded quality factor, 171–73, 174
- Load impedance, 12
- Local oscillator, 287, 323
- Lossless transmission line, 8
- Low-loss filter, 112–13, 207, 215–18, 253
- Low-loss interdigital filter, 253–56
- Low-noise amplifier, 288
- Low-temperature cofired ceramics, 75–77

- Lu's visualization approach, 82
- Machinability, 55, 340
- Machining costs, 142
- Machining technologies, 211–15
- Macro cutting, 250
- Macro welding, 156
- Magnesia-silicon carbide, 70
- Magnesium, 261
- Magnesium aluminate, 273
- Magnesium oxide, 70–71
- Magnesium oxide-silicon carbide, 70
- Magnesium silicate, 76
- Magnetic field, 6–7, 8, 13, 20, 24
- Magnetic loop waveguide, 257
- Magnetic-particle inspection, 312
- Magnetic-pulse forming, 267
- Magnetron, 27
- Maintenance costs, 138, 139
- Manufacturability care, 131
- Manufacturability design, 122–29
- Manufacturability for concurrent engineering, 133–34
- Manufacturability-oriented design, 161
- Manufacturability-oriented embodiment design, 42
- Manufacturability-oriented parametric design, 113–14
- Manufacturing and designing, barrier between, 123–25
- Manufacturing costs, 120, 121–22, 134, 142
- Material costs, 120, 141
- Material inhomogeneity, 46
- Material parameters, welding, 157
- Material problems, 15–26
- Material optimization, 144
- Material selection, 161, 341
- Mathematical model, 36, 40
- Maximum material principle, 112
- Maxwell's equations, 4–8
- Measuring system
 - dimensional uncertainties, 303–10
 - geometrical tolerances, 304–10
 - surface properties, 310–17
 - wood quality, 285–94
- Mechanical engineering, 102–3, 129–30, 147
- Mechanical imperfection, 21–22
- Mechanical parameters, 112–14
- Mechatronics, 130
- Meshing, 100
- Metal active gas, 93
- Metal alloy, 50–51
- Metal electroless forming, 273
- Metal inert gas, 93, 155, 180–82, 184–88
- Metallic components, 54–64
- Metallographic testing, 312
- Metallurgical transformation, 311, 312, 317
- Method 635, 30, 32
- Method of moments, 99
- MGRID structure editor, 97
- Microphonics, 144
- Microstrip technology, 26–27, 243, 244, 246–49
- Microwave and millimeter wave integrated circuit, 288, 290
- Microwave circulator, 27
- Microwave-engineering design phase, 133
- Microwave device, 87
- Microwave design computer-aided design, 103–8
- Microwave mechanics, 129–30, 136, 148
- Microwave software, 100
- Mildly activated flux, 194
- Milled connector design, 229–31
- Milled construction, 134, 165, 174, 193, 209, 211, 213, 215, 244, 253
- Milled enclosure, 224–29
- Milled filter, 215–18, 305–6
- Millimeter wave, 26, 171
- MIL-STD-833 Method 2020, 318
- MiniCircuits VNA-25 chip, 195–97
- Mixer, 328
- Mobile communications, 27
- Model costs, 141
- Modular construction, 42, 84, 123, 125, 179
- Molding costs, 141
- Monolithic microwave integrated circuit, 96, 98
- Monopole antenna, 296
- Multichannel rotary joint, 235–37
- Multilevel optimization, 141–48

- Multiprocessing, 144, 147, 250
- Multirepresentation architecture, 81
- Nd:YAG laser, 155, 156, 158–61, 164, 180–81, 251–52, 256, 341
- Near field, 20
- Nesting, 141
- Networking, 85, 89
- New product, 137
- Nickel, 51, 269, 272, 275
- Nickel-iron alloy, 62–64
- Nickel plating, 274, 276
- Nickel silver, 51
- Nonperfect conductivity, 26
- Nonperfect welding joint, 25–26
- Ohm's law, 16
- Open mold processing, 265
- Operating costs, laser processing, 137, 138, 139–40
- Operating environment effects, 51–54
- Operating frequency effects, 47–51
- Optical element costs, 138, 140
- Optimization, machining, 213–22
- Organic coating, 272, 273
- Organizational aspects, teamwork, 132
- Outer conductor, 57
- Outer contact, 58
- Oxidation, 53, 173, 274–75
- Oxide layer, 311
- Oxinitride transition layer, 275
- Oxygen-free copper, 55–56
- Palladium, 273
- Parabolic antenna, 296, 298
- Parallel capacitance, 9
- Parallel engineering, 131
- Parallelism, 306–7, 309
- Parallel wind, 298
- Parameterization, 132–33
- Parametric modeling, 84, 90, 111, 112–14, 126, 135–36, 340
- Pareto, 85
- Particle impact noise detection, 194, 318
- Parts, minimizing, 123, 125
- Passivation, 274, 275
- Passive intermodulation, 274, 324, 327–29
- Passive microwave component, 127, 205, 243, 253, 322, 323
- Patch antenna, 66, 296–97, 333
 - radiating elements, 177–92
- Pattern performance, 22
- Penetration depth, 17, 18, 19, 48–51
- Perfluoralkoxy, 65, 67
- Performance-oriented optimization, 144, 145, 161
- Performance-oriented parametric modeling, 113–15
- Permeability, 153
- Permittivity, 16, 47–48, 153
- Perpendicular wind, 298
- Phase constant, 16, 24, 25
- Phased array antenna, 332–37
- Phase error, 334, 335
- Phosphorus bronze, 57
- Physical loading conditions, 170
- Physical optics, 99
- Planar design, 26–27
- Planning task phase, 30
- Plasma arc welding, 155, 180
- Plastics, 53, 164, 206, 311
 - extrusion, 261, 262, 264
 - hardness, 317
 - shaping, 264–66
 - types, 64–67
 - welding, 156, 164
- Polarization characteristics, 171
- Polar notation, 9
- Polycarbonate, 66
- Polyether-etherketone, 65, 67
- Polyethylene, 64–65, 67
- Polymer system, 275
- Polyphenylene oxide, 66
- Polytetrafluoroethylene, 64, 67, 104, 127, 159, 162, 164
- Polyurethane adhesive, 208
- Polyvinyl chloride, 265
- Positioning system, 138
- Postprocessing, welding, 156
- Powder metallurgy, 66–77, 134, 142
- Powder production, 68
- Power combiner, 27
- Power divider, 27, 178, 218–24, 243, 251, 287
- Precision machining, 237–40, 245
- Precision resonator, 27

- PREFEKO, 99
Preprocessing, 143
Press joint. *See* TOX joining
Printed circuit board, 243, 274, 279–80
Probe-fed antenna, 330–31
Process control, 146
Process management, 131
Process parameters, 157
Product costs, total, 148
Product data management system, 130
Product development, 161
Production costs, 148
Production management, 131
Programming costs, laser, 137, 139
Projection welding, 197–99
Propagation, 5–8, 157
Prototype costs, 134
Pulsed laser, 155
Pyramidal extension, 20
- Quality aspects, 135
Quality factor, resonator, 171–74
Quality-oriented decision making, 131
Quarter-wave patch antenna, 178–92
Questionnaire, 31, 33, 35–38, 129
- Radar cross section, 99, 100, 101, 290
Radar system, 231, 243
Radiating element, 177–92
Radiation damage, 53
Radiation-resistant wire insulator, 65
Radio frequency block, 27
Radio frequency excitation, 156
Radio frequency parameter, 112–14
Radio frequency sputtering, 272
Radome, 296, 300
Rapid prototyping, 125, 134
Ratios, optimizing procedure, 148
Reaction injection molding, 266
Receive unit, 247
Rectangular cavity resonator, 172–74
Rectangular horn antenna, 21–22, 154
Rectangular quarter wave patch antenna, 87–88, 91–93, 92
Rectangular tube, 20
Rectangular waveguide, 23, 25, 26, 256–57, 289–91, 308
Recurrence cost, 179
- Recycling, 130
Redesign costs, 137
Redesigned product, 137
Reflector antenna, 296, 298
Reinforced plastics, 66, 264, 265
Repeatability, welding, 156
Requirements list, 33–34, 35–36, 39, 40
Resilient contact, 57
Resistance spot welding, 93
Resistivity value analysis, 50–51
Resistor, 75
Resonant vortex effect, 299, 300
Resonator, 75, 166, 215, 216, 281
 sapphire, 238–39
 cavity resonator, 27, 113, 154, 161, 170–77, 238–39
Resonator base, 216
Resonator oscillator, 287
Reversed extrusion, 261
Reverse engineering, 128
RG-58 cable, 325
Rhodium, 275
Ring-hybrid construction, 209, 218–24, 246–49, 335–37
Riveting, 180
Rockwell hardness test, 317
Rodenacker's design approach, 30
Roll forming, 267, 268
Rotary joint, 231–37, 281
Rotating disk, 164
Rotational joint, 312
Rotational molding, 266
Rubber sealing, 234
Rule-based design system, 84, 85
- Samarium cobalt, 73–75
Sandwich structure, 144
Sapphire resonator, 238–39
S-band antenna, 180, 249, 332
S-band ring hybrid, 222–24
S-band space application, 281
S-band transducer, 291
Scale factor, 112
Scale model, 134
Scaling dimensions, 332
Scattering parameter amplitude, 14–15
Screw joint, 113, 179, 184, 203–5

- Sealed microwave component, 313
- Seam welding, 155, 159, 161, 176
- Self-excited vibration, 228
- Series resonant behavior, 173
- Service costs, 138, 139–40
- Shearing stresses, 164
- Sheet metal cutting, 139, 142, 211, 243–46
- Sheet metal forming, 267–68
- Sheet metal welding, 159–64, 167, 174, 176
- Shielding performance, 329–30
- Sidelobe performance, 24
- Signal generator, 321, 324–25
- Silicon alloy, 222
- Silicon aluminum nitride, 275
- Silicon-based adhesive, 208
- Silicon carbide, 70
- Silicone compound, 207
- Silicon-tungstic acid, 275–76
- Silver, 45–46, 51, 76–77, 206–7, 269
- Silver alloy, 274–75
- Silver-based adhesive, 206–7
- Silver plating, 58, 273, 274–76, 280
- Similarity laws, 136
- Simulation models
 - impulse radar antenna, 103–8
 - patch antenna, 189–90
 - stripline filter, 94–96
- Simulation software solutions, 96–102
- Simultaneous engineering, 131
- Sintering, powder metallurgy, 68
- Sinusoidal signal, 8, 9, 19–22
- Skin effect, 45, 280
- Slab laser, 156, 250
- Slot antenna, 292–93, 331–32
- Slow axial flow, 250
- Smart antenna, 297
- Smith chart, 14, 15, 106–7, 108, 173, 216, 257–58, 322, 342
- Social aspects, 132
- Software development, 91
- Soldered joint tests, 166–67
- Soldering, 156, 159, 180, 193, 194
- Solder sealing, 194
- Sonotrode, 164, 168
- Specific absorption, 102
- Spectrum analyzer, 321, 323–24, 325, 328
- Splatter, 311
- Spot welding, 155, 161, 180, 184
- Stability, metallic components, 55
- Stainless steel, 19, 58–60, 159, 161, 234, 280, 282
- Stainless steel resonator, 173–74, 175
- Stamped steel, 116
- Standardization, 42, 123, 126, 179, 211, 214, 215, 221
- Standing wave ratio, 14, 104–8, 322
- Statistical process control, 85
- Steatite insulator, 69
- Steel, 19, 45, 49, 50, 51, 58–60, 93, 116, 155, 180, 185, 261, 262, 282, 328
- Steel resonator, 171, 173–74, 175
- Step-wise refinement, 132, 133, 171
- Stereo lithography file format, 125, 129
- Stress relaxation, 55
- Stretching sheet metal, 267, 268
- Stripline feeding network, 249
- Stripline filter, 157–64
- Stripline technology, 26–27, 243, 244, 245, 246–56, 328
- Structural optimization, 144, 145
- Subjective information, manufacturing, 126
- Sublimation cutting, 250
- Submerged plasma arc welding, 180
- Subminiature A connector, 57, 158–59, 164–65, 166, 167, 207, 209, 210, 215, 218–21, 231, 274, 322, 325
- Subproblem division, 31
- Sucoplate, 276–77
- Sulfamate nickel, 279
- Superconductor, 67
- Superconductor oxygen-free copper, 55–56
- Super-plastic forming, 267, 268
- Surface finish/texture, 113–14, 121, 134–35, 167, 312–14
 - defects, 263, 311–12
 - measuring, 310–17
- Sweep time, 323–24
- Swivel joint, 234
- Symmetrical geometries, 214
- Synetics, 30, 32

- Systematic design, 29–34, 126
Systematic variation method, 32
- Taguchi method, 146
Task clarification, 30, 33–34
Teamwork, 36, 39–40, 124, 129–31, 132, 133, 134
Tearred surface, 263
Teflon, 46, 53
Temperature, operating environment, 52, 54, 213, 234
Temperature effect, welding, 154, 159, 161, 166, 182
Tensile strength, 55
Termination, 278–79
Test antenna performance, 91–92
Testing costs, 138
Thermal conduction welding, 155
Thermal spraying, 272
Thermoforming, 264–65
Thermoplastics, 164
Thick film hybrid technology, 76
Thin-film technology, 253
Third generation system, 255
Third-order Butterworth filter, 255–56
Third-order intermodulation, 328
Three-dimensional coordinate measuring system, 304, 307–9
Three-dimensional field pattern, 171
Three-dimensional modeling, 82, 84, 85, 88, 96, 97, 99, 100, 128, 129, 133, 134, 146
Times diffraction limited factor, 157
Tin, 51, 272, 279
Tin chloride, 275
Tin-lead alloy, 276, 279
Tolerance factor “i,” 213
Tolerances
 extrusion, 264
 general manufacturing, 111, 116–18
 geometrical, 112, 116–18, 187, 189, 304–10
 ISO, 117, 210, 213, 237, 245, 305
 transducer, 292
Tooling costs, 140, 141, 213, 244, 267
Tooling system, 167
Tool wear, 212, 213
Topic area, 153–54
Torsion component, 298, 299
TOX joining, 179, 184–85, 187–88
TOX pressing, 93
Transducer, 154, 164, 289–94
Transition fit, 209
Transmission line cross-sectional structure, 3
Transmission line insulation, 46–47
Transmission line theory, 177
Transmit-receive unit, 247
Transmitter tube, 27
Transversal phase constant, 25
Transverse electric mode, 13, 23, 25, 172, 173, 234, 239, 257, 280, 289
Transverse magnetic mode, 239
Transverse phase coefficient, 22
Trapezoidal impulse radar antenna, 103–8
Tschebyscheff bandpass filter, 215–18
T-switch, 281
Tubular coaxial filter, 239–40
Tuned design methodology, 34–42
Tuned optimizing algorithm, 142–48
Tungsten inert gas, 93, 155, 156, 180–82
Tuning, 134
Tuning coaxial transition, 256–58
Turning, 211
Two-and-a-half dimensional modeling, 96
Two-dimensional modeling, 84, 96
Two-port calibration, 322
- Ultraprecision machining, 211, 229, 231, 237–40, 341
Ultrasonic machining, 69
Ultrasonic welding, 57, 154, 161, 195
 filter constructions, 164–70
Ultraviolet radiation-cured adhesive, 206
Unique product, 137
Universal mobile telecommunications system, 255
Unloaded quality factor, 173–74
Upsetting-pressing process, 179
User profile, 27
- Vacuum evaporation, 272
Value analysis, 31, 42
Vapor deposition, 272

- Vector network analyzer, 14, 106–7, 174, 195–97, 224, 286, 321, 322–23, 342
- Vector network analyzer four-port method, 180
- Vector potential, 20
- Verein Deutscher Ingenieure 2221, 31, 32, 126
- Vibration, 52, 54, 227–28
- Vickers hardness test, 317
- Virtual engineering, 86–94, 129, 134, 340
- Virtual environment, 81
- Virtual impedance, 11–12
- Virtual manufacturing, 127
- Virtual model, 84, 85
- Virtual prototyping, 127
- Virtual reality, 86–87
- Visualization approach, 82
- Voltage reflection coefficient, 11, 12, 14
- Voltage standing wave ratio, 215
- Volume production, 141, 147, 159, 161, 170, 267
- Vortex shedding effect, 298–300
- Water jet cut ring hybrid, 246–48
- Water jet cut stripline feeding network, 249
- Wave equation, 6–8, 8
- Waveguide, 76, 161, 205
 - electroforming process, 268–69, 273
 - input impedance, 330–32
 - joint geometries, 170–77
 - rectangular, 23, 25, 26, 256–57, 289–91, 308
 - surface plating, 280
 - transition design, 256–58
- Waveguide bandpass filter, 280
- Waveguide valve, 280
- Wear measurement, 315–17
- Wear mechanics, 53–54
- Weight gain measurement, 318
- Weldability, 42, 90, 153–54, 340
- Welded device
 - costs, 138, 139, 141
 - critical areas, 93–94
 - deformations, 145, 161, 162, 177, 189–92, 311, 334–35
 - design problems, 90–91
 - procedure specification, 90, 112, 117
- Welded stripline filter, 94–96
- Welding processes, topic area, 153–54
- Welding tip, 164
- Whispering gallery mode resonator, 238–39
- Wideband antenna test, 103–8
- Wilkinson-type power divider, 251
- Wind load, 297–300
- Windows environment, 81, 99, 101, 104
- WinFEKO, 101
- Wire coating, 65
- Wire drawing processes, 266–67
- Wishes list, 33
- Wood quality measurement, 285–94
- Work breakdown structure, 132
- Workpiece manipulator system, 137, 138, 139, 140
- Zinc, 272