

**MTEMS**  
**(Military Tactical Equipment Maintenance System)**



**BY**

**CAPT MUDASSAR SADIQ**

**CAPT HAFIZ M. ANWER KHAN**

**CAPT NAQASH ALI**

**CAPT SOHAIB HASSAN**

**SUPERVISOR**

**MAJ WAJAHAT SULTAN**

Submitted to the Faculty of Software Department  
National University of Sciences and Technology, Islamabad  
in partial fulfillment for the requirements of a B.E Degree in  
Computer Software Engineering

**June 2021**

## CERTIFICATE OF CORRECTION & APPROVAL

*This is to officially state that the thesis work contained in this report titled “MTEMS” (Military Tactical Equipment Maintenance System Service) Is carried out by: Capt Mudassar Sadiq, Capt Hafiz Muhammad Anwer Khan, Capt Naqash Ali, Capt Sohaib Hassan, under my supervision and that in my judgment, it is fully ample, in scope and excellence, for the degree of Bachelor of Computer Software Engineering from National University of Sciences and Technology (NUST).*

**Approved By:**

**Signature:** \_\_\_\_\_

**Supervisor: Maj Wajahat Sultan**  
**MCS, NUST Rawalpindi**

## **DECLARATION OF ORIGINALITY**

We hereby declare that the work contained in this report and the intellectual content of this report are the product of our work. This thesis report has not been formerly published in any structure nor does it include any verbatim of the published resources which could be treated as violation of the international copyright decree. We also affirm that we do recognize the terms 'plagiarism' and 'copyright' and that in case of any copyright infringement or plagiarism established in this thesis, we will be held fully accountable of the consequences of any such violation.

## Plagiarism Certificate (Turnitin Report)

This thesis has been checked for Plagiarism. Turnitin report endorsed by Supervisor is attached at the end of the document.

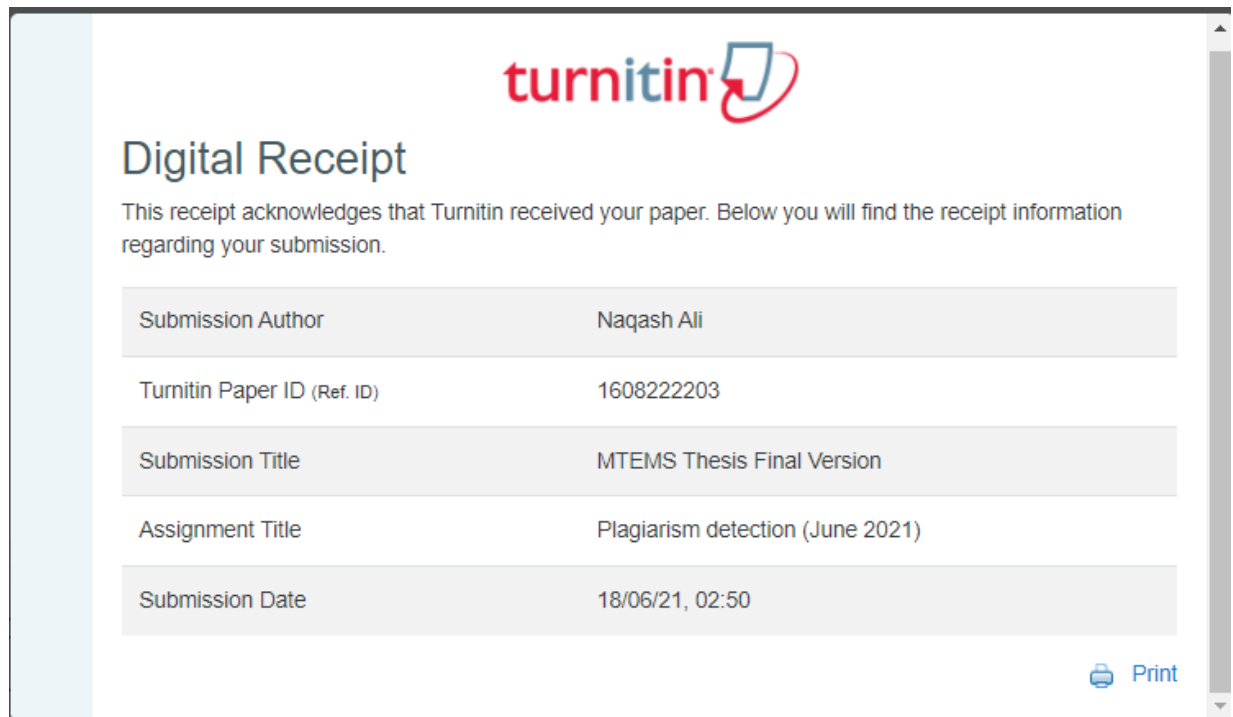

The image shows a screenshot of a Turnitin Digital Receipt. At the top center is the Turnitin logo. Below it, the title "Digital Receipt" is displayed. A paragraph of text states: "This receipt acknowledges that Turnitin received your paper. Below you will find the receipt information regarding your submission." Below this text is a table with five rows, each containing a label and a value. At the bottom right of the receipt area, there is a "Print" button with a printer icon.

Submission Author	Naqash Ali
Turnitin Paper ID (Ref. ID)	1608222203
Submission Title	MTEMS Thesis Final Version
Assignment Title	Plagiarism detection (June 2021)
Submission Date	18/06/21, 02:50

Print

**Signature:** \_\_\_\_\_

**Supervisor:** *Maj Wajahat Sultan*

## ACKNOWLEDGEMENTS

In the name of Allah, the most merciful and the most Beneficent, Who led us to this extent. May all glory, honor and Adoration be unto Thy Name.

Our special thanks go to our supervisor **Maj Wajahat Sultan** for guiding us throughout the process that resulted in the successful completion of our project. We would also like to thanks to the faculty of Software Department specially **Dr. Athar Mohsin Zaidi, Lec Mobeena Shehzad, Maj Zeeshan Zulkifl** for their guidance in the development of the project.

A deep gratitude towards **Dr. Adnan Ahmed Khan** (Head of Computer Software Department) for his guidance and facilitation for the Project.

At last, we are most obliged to our Parents, their support contributed immensely to the success of this project.

*Dedicated to our exceptional parents and adored siblings whose tremendous support and cooperation led us to this wonderful accomplishment.*

## **ABSTRACT**

Military equipment is one of the pillars for any modern Military. Military mobility and effectiveness depends on the availability of its operational equipment. Military equipment and platforms have evolved significantly and so does the maintenance systems.

According to Pakistan military equipment we will be looking for military vehicles and weapons.

To cater for the problem and to reduce the manual handling of records besides providing user assistance we as a team have come with the proposal named as “MTEMS” stands for Military Tactical Equipment Maintenance System.

As the name is self explanatory it highlights that our project will construct into a web application using the existance Earms application protocols. It will provide user a service of real time entry of records , automated generation of records and prediction for the availability of equipment. MTEMS is a new concept besides the availability of Earms systems in Pakistan Military. MTEMS will predict maintenance of parts, automated generation of work orders, prediction the availability of equipment state. None of the present systems provides these features.

## Table of Contents

Plagiarism Certificate (Turnitin Report) .....	iv
Chapter 1 .....	1
1 Introduction.....	2
1.1 Intended Audience and Reading Suggestions.....	2
1.2 Motivation.....	3
1.3 Project Vision .....	3
1.4 Project Objective.....	4
1.4.1 Primary Objectives:.....	4
1.4.2 Academic objectives:.....	4
1.4.3 Application / End – goal objectives: .....	4
1.5 Deliverables.....	4
Chapter 2.....	5
2 Literature Review .....	6
2.1 Introduction.....	6
2.2 Problem Domain .....	6
2.3 Related Work.....	7
2.4 Shortcomings/issues.....	7
2.5 Proposed Project .....	8
2.6 Deliverables.....	8



2.6.1	Software Requirement Specification (SRS).....	8
2.6.2	Software Architecture Document.....	9
2.6.3	Software Design document.....	9
2.6.4	Implementation code Document.....	9
2.6.5	Software Testing Document.....	9
2.6.6	Final Project Report.....	9
2.6.7	User Manual.....	10
2.7	Technological Requirements.....	10
2.7.1	Software Interfaces.....	10
2.7.2	Hardware Interfaces.....	10
2.7.3	Programming Interface.....	11
Chapter 3	.....	12
3	Overall Description.....	13
3.1	Product Perspective.....	13
3.2	Product Functions.....	13
3.2.1	User Profiles.....	13
3.2.2	Sensors Input.....	13
3.2.3	Alerts and Reports.....	13
3.2.4	External connectivity.....	14
3.2.5	Login/Access Right.....	14

3.3	Operating Environment.....	14
3.3.1	Technology Platform:.....	15
3.4	Design and Implementation Constraints.....	15
3.5	User Documentation .....	16
3.6	Assumptions and Dependencies .....	16
Chapter 4	.....	17
4	Software Requirements Specification.....	18
4.1	System Features.....	18
4.1.1	Use Case UC1: Create Account.....	19
4.1.2	Use Case UC2: Confirm Duty Slip.....	20
4.1.3	Use Case UC3: Fitness certificate and Workorders.....	20
4.1.4	Use Case UC4: View Details of vehicles and weapons.....	21
4.1.5	Use Case UC5: Send Duty slip for approval.....	22
4.1.6	Use Case UC6: View and send work order for approval .....	23
4.1.7	Use Case UC7: Verify and signature duty slip .....	24
4.1.8	Use Case UC8: View and send fitness certificate for approval to CO.....	25
4.1.9	Use Case UC9: Vehicles Registration .....	26
4.1.10	Use Case UC10: View Vehicle Reading Received through Sensor.....	27
	Table 10 View Vehicle Reading Received through Sensor.....	28
4.1.11	Use Case UC11 : Generate Fitness Certificate for Vehicle.....	28

Table 11 Generate Fitness Certificate for Vehicle .....	29
4.1.12 Use Case UC12: Generate Duty slips.....	29
4.1.13 Use Case UC13: Send work order for approval .....	30
Table 13 Send work order for approval .....	31
4.1.14 Use Case UC14: Verify Duty Slip .....	31
4.1.15 Use Case UC15: Generate maintenance form.....	33
4.1.16 Use Case UC16: Generate Maintenance form.....	34
4.1.17 Use Case UC17: Weapon Registration .....	35
4.1.18 Use Case UC18: Assign Weapon using Bar code.....	36
4.1.19 Use Case UC19: View Weapons Assigning Details .....	37
Table 19 View Weapons Assigning Details .....	38
4.2 Other Non-functional Requirements.....	38
4.2.1 Performance Requirements.....	38
4.2.2 Safety Requirements .....	38
4.2.3 Security Requirements .....	38
4.2.4 Software Quality Attributes .....	38
4.2.5 Business rules: .....	39
4.3 Software Quality Attributes .....	39
4.3.1 Runtime System Qualities .....	39
Chapter 5.....	41

5	System Design Specifications.....	42
5.1	System Architectural Design.....	42
5.2	Class Diagram.....	43
5.3	Use Case Diagram .....	44
5.4	Sequence Diagrams.....	45
5.5	Login-Success & Failure: .....	45
5.5.1	Account Creation Success & Failure: .....	46
5.5.2	Duty Slips Success & Failure .....	47
5.5.3	Maintenance Form Success & Failure.....	48
5.5.4	Work Order Success & Failure.....	49
5.5.5	Fitness Certificate Success & Failure .....	50
5.5.6	Assign Weapon.....	51
5.6	Activity Diagrams.....	51
5.7	Design Rationale .....	55
5.8	Component Design.....	56
Chapter 6	.....	57
6	System Implementation.....	58
6.1	Technology Used.....	58
6.1.1	Programming Language Used .....	58
6.1.2	Development Tools .....	58

6.1.3	Database .....	58
6.1.4	Operating System.....	58
6.2	Complete System Implementation.....	58
6.2.1	Login Page .....	58
6.2.2	Creating Account.....	59
6.2.3	View Listed users .....	60
6.2.4	Register New Vehicles/ Weapons .....	60
6.2.5	Fitness certificate/ Duty Slip .....	62
Chapter 7	.....	63
7	System Implementation.....	64
7.1	Overview .....	64
7.2	Unit Testing .....	64
7.2.1	Login Feature Testing.....	64
7.2.2	Creating Account feature Testing .....	65
Chapter 8	.....	68
8	Conclusion and Future Work.....	69
8.1	Conclusion .....	69
8.2	Future work.....	69
Glossary	.....	70
Bibliography	.....	72

## LIST OF TABLES

Table 1 Create Account.....	<b>Error! Bookmark not defined.</b>	19
Table 2 Confirm Duty Slip .....		20
Table 3 Fitness certificate and Workorders .....		20
Table 4 View Details of vehicles and weapons .....		22
Table 5 Send Duty slip for Approval.....		23
Table 6 View and send work order for approval .....		23
Table 7 Verify and signature duty slip .....		25
Table 8 View and send fitness certificate for approval to CO .....		26
Table 9 Vehicles Registration.....		27
Table 10 View Vehicle Reading Received through Sensor .....		28
Table 11 Generate Fitness Certificate for Vehicle .....		29
Table 12 Generate Duty slips.....		30
Table 13 Send work order for approval .....		31
Table 14 Verify Duty Slip.....		33

Table 15 Generate maintenance form.....	34
Table 16 Generate Maintenance form.....	35
Table 17 Weapon Registration.....	35
Table 18 Assign Weapon using Bar code .....	37
Table 19 View Weapons Assigning Details .....	37
Table 20 System Login Testing .....	64
Table 21 Creating Account Feature Testing.....	66
Table 22 Glossary.....	70

## **LIST OF FIGURES**

Figure 1 Use case Diagram.....	18
Figure 2 System Architectural Design .....	42
Figure 3 Class Diagram.....	43
Figure 4 Use Case Diagram.....	44
Figure 5 Sequence Diagram Login.....	445
Figure 6 Account Creation Success & Failure.....	46
Figure 7 Sequence diagram Duty Slips Success & Failure .....	47
Figure 8 Sequence diagram Maintenance Form Success & Failure .....	48
Figure 9 Sequence Diagram Work Order Success & Failure .....	49
Figure 10 Sequence Diagram Fitness Certificate Success & Failure .....	500

Figure 11 Sequence diagram Assign Weapon .....	511
Figure 12 Activity Diagram: Activity Diagram - CO .....	52
Figure 13 Activity Diagram: Activity Diagram – QM.....	53
Figure 14 Activity Diagram: Activity Diagram – KOTE NCO .....	54
Figure 15 Activity Diagram: Activity Diagram – NCO.....	55
Figure 16 Login Page .....	59
Figure 17 Creating Account page.....	59
Figure 18 View Listed users .....	60
Figure 19 Register New Vehicles/ Weapons .....	61
Figure 20 Fitness certificate/ Duty Slip .....	62





# Chapter 1

# 1 Introduction

The current System in Pakistan Army for maintenance of equipment is manual and paper-based which is both slow and cumbersome. Users got to record each entry manually which in turn increases probability of human errors, search a number of ledgers for periodic maintenance of equipment and/or track workorders manually for feedback on the equipment sent for any repairs. All this cumbersome activity slows down the pace of the work and workload on the staff increases many folds. This lag is not affordable in any way keeping in view the modern and volatile battlefield situation.

In this project we develop a comprehensive solution that shall not only maximize the speed of the process but also shall provide supportive measures like automated entries for minimizing human errors and application will reduce the workload.

MTEMS will be Network based application that will automate the whole process of entries into the database, recordkeeping, notification for required maintenance and generating the periodic workorders.

This way MTEMS will provide us an automated system for maintenance of the equipment thus reducing human error probability, enhancing the efficiency, and minimizing the workload on the concerned staff.

## 1.1 Intended Audience and Reading Suggestions

This document is meant for all the stake holders.

- **Project Supervisor:** It will assist to supervise the project and guide the group available by better manner.
- **Development Team:** It will assist the developer to develop the application and to discover back the functional requirements.
- **Testing Team:** Designed to assist testers to comprehend the constraints.
- **Users:** Users of the system include the staff (including Quarter Master and Commanding officer) responsible for maintenance of unit's Mechanical transport.

- **UG Project Evaluation Team:** Assessment board which will evaluate the assessment and evolution of UG Projects.

## **1.2 Motivation**

Since mobile phones and computers have become an intrinsic part of our daily lives, and made every process quicker and reliable so, why not use them to save our time and effort in a new way. The traditional ways of handling the records and maintenance service is based on ledger system being maintained centrally in units. Entries are recorded manually for divergent equipment used on daily basis. This manual entry system increases the probability of errors or omissions, also increases the workload as these entries are to be searched as well for periodic maintenance of the equipment.

Even when the Equipment has been sent for repairs, it is difficult to remember every workorder and return dates. For this purpose, again the ledgers are scanned, and feedback is asked for the equipment at the last moment.

All these problems pushed us to design a viable solution for the speedy and reliable system that provides a better solution using modern day techniques and eliminates the lag posed by legacy system.

## **1.3 Project Vision**

We propose a system that will provide core functionalities i.e. keep a record of vehicle daily running, periodic maintenance like battery changes, oil change etc. prompt the repairs required for the weapons. This application provides automated entries into the database, an attractive dashboard, and automated reports for the summary of the state of equipment (may be required for planning).

- User launches app and can view current state of the equipment.
- Reports and alerts are generated for both the staff and officers.
- Staff can forward the workorders to officers for approval.

This way MTEMS will provide equipment handling services that will be precise, accurate and with the required speed to save the precious time and effort thus reducing fatigue and workload.

## **1.4 Project Objective**

### **1.4.1 Primary Objectives:**

1. Manage Mechanical Transport Daily running account.
2. Minimize the errors and omissions in record keeping.
3. Minimized time & effort required to search the ledgers for any impending repairs required.
4. Real Time Dashboard for quick view of the equipment state and maintenance analysis.

### **1.4.2 Academic objectives:**

1. Web development.
2. To have a good hand on using SQL, Bootstrap
3. To automate the existing legacy system
4. Introducing a shared medium for end user staff and administrative officers.

### **1.4.3 Application / End – goal objectives:**

1. To facilitate the end users of the application in terms of equipment maintenance.
2. To enable military units, handle their vital equipment accurately, reliably and on time.
3. To save time and effort of the staff thus reducing the fatigue and workload.
4. Real time smart automated prediction for availability of equipment.
5. Automation of work orders for maintenance of equipment.

## **1.5 Deliverables**

1. Complete working project.
2. Web based application.
3. Documentation.
4. Video of working of project.

# Chapter 2

## **2 Literature Review**

### **2.1 Introduction**

There are some android and IOS applications that have been developed on similar lines. We can adopt the same mechanism to develop a web-based application to be used within local network of Pakistan Army. This application will be isolated from Internet and aims at replacing the existing legacy paper- based system which is cumbersome and slow.

Conventional applications for such purpose provide such facility for just one vehicle per user account. MTEM will be different in terms of its features like dashboard, handling of divergent vehicle and equipment and minimum human effort requirement for maintenance of complete inventory including the vehicles and weapons. The main intention of the project is to set up a system in form of web-based application that will automate the whole process of record keeping, entries into database, generation of workorders and notifications in advance for any periodic repairs required.

### **2.2 Problem Domain**

Keeping in view the current system, staff needs to manually check the odometers of vehicles returning to the unit parking from any duty, then these reading are recorded in a ledger and log-book (separate for every vehicle), periodic maintenance is delayed because every time log-books are to be checked for every vehicle for finding dates/ milage for determining the time for change of oil, tyres, battery etc.

This process incurs many problems, like:

1. Inability of the staff to update the ledgers on daily basis because of other security and administrative duties.
2. All the ledgers cannot be scanned by the staff on daily basis for any periodic maintenance coming up.
3. Conventional process is time consuming and slow.

It urges the use of modern technology to minimize the effects of this existing disparity by making a web-based application to enable the user units to keep the equipment battle ready through the usage of an automated system.

### **2.3 Related Work**

Currently there is no such system working in Pakistan Army that provides such services. We can adopt the same mechanism to develop an android application for emergency and medical transfer services of the patients.

Project Objectives that distinguish our solution from the others:

1. "MTEMS" becomes the pioneer in Pakistan Army to provide services through an automated system.
2. Our application can be deployed in Army at unit level.
3. Will minimize the lag and errors in maintenance of equipment.
4. To develop an automated system for the units, providing services to facilitate the staff in precise and efficient way.
5. Will minimize the time and effort of the staff and facilitates more accurate and up to date records.

### **2.4 Shortcomings/issues**

1. Intranet connection is essential for the working of MTEMS.
2. The application is web-based.
3. Currently cannot be deployed at massive level like for complete formations.
4. At present it cannot be deployed in exercise areas due to lack of network infrastructure.
5. Currently we are using sensors, their reading accuracy is to be determined precisely after repeated trials.



6. The server will not be available in case of maintenance and testing issues. No backup server configuration is provided.

## **2.5 Proposed Project**

The purpose of our project is to computerize and automate the currently existing manual paper-based system of military equipment Management, thus getting the processes faster, less cumbersome, reliable, and efficient.

This software currently is a self-contained system and can be a part of a larger system e.g. E-ARMS. The main parts of the project include sensors to read data and the other is record keeping for reports and alerts generation and summary of the overall state and condition of the equipment.

To cater for the problem and to reduce the manual handling of records besides providing user assistance we as a team have come with the proposal named as “MTEMS” stands for Military Tactical Equipment Maintenance System.

As the name is self explanatory it highlights that our project will provide user a service of real time entry of records, automated generation of records and prediction for the availability of equipment. MTEMS will predict maintenance of parts, automated generation of work orders, predicting the availability of equipment state.

## **2.6 Deliverables**

### **2.6.1 Software Requirement Specification (SRS)**

The purpose of the document is towards the introduction of a comprehensive picture of the MTEMS. It describes the persistence and characteristics of the system, the interfaces, the boundaries of the system, whatever the product will do, its processes and workings, noted that the constraints by which it ought to operate and how the system is going to act in response to exterior stimuli. This paper is intended for developers and the participants of the system. It shall describe how the system will primarily aid concerned groups to team up and cooperate with each other.

## **2.6.2 Software Architecture Document**

In this document the overall architecture of the system is discoursed, also including the introduction of various components and subsystems. It is chiefly braced by system Architecture diagram which depicts an insider's viewpoint of the system by unfolding the high-level software components that execute the major functions to make the system operational.

## **2.6.3 Software Design document**

The Software Design Document is a record to give documentation that shall be utilized to help in programming advancement by giving the subtleties to how the product ought to be fabricated. Inside the Software Design Document are narratives and graphical documentation of the product plan for the task. It covers every single practical prerequisite and shows how they communicate with one another adroitly. The low-level design additionally appears with respect to how really, we have been executing how we are going to actualize these requirements.

## **2.6.4 Implementation code Document**

The implementation code document provides details about the pseudo code for the application and project prototype.

## **2.6.5 Software Testing Document**

This document has testing modules in which there are certain test cases which depicts the correctness and accuracy of the project.

## **2.6.6 Final Project Report**

This is the thesis report which compiles all the previous and current working for the project. Thesis report provides the whole summary for the project and also give details about each and every aspect of the project starting from introduction of the project,

literature review, requirements leading to design discussions then testing and lastly future work and conclusion.

### **2.6.7 User Manual**

User Manual gives details about the use of the product. It contains details as how to use the product. Its functionalities and details of every aspect as how that works and how to use it. User Manual is for users to get to know the product.

## **2.7 Technological Requirements**

MTEMS entails subsequent software and hardware requirements specifications.

### **2.7.1 Software Interfaces**

1. MTEMS shall work on MS SQL database management system.
2. MTEMS app shall be able to execute on all PCs with basic hardware requirements fulfilled that run windows 10.
3. The app will require IIS Server.

### **2.7.2 Hardware Interfaces**

#### **2.7.2.1 Mobile Device**

The hardware, software and technology used must possess the subsequent specifications:

1. Bar code reader.
2. Accelerometer.
3. Personal Computer.
4. Operating System: Windows 10.
5. Capability to exchange information across the network.
6. Processor with speed of 1 GHz or above.

7. Ability to take over input from user.
8. PC needs to have at least 8 GB of RAM.

### **2.7.3 Programming Interface**

Programming interfaces for project are:

1. Front End: Bootstrap JQuery, HTML 5, CSS 3
2. Backend Coding Tool: Visual Studio
3. Backend Language: C#
4. Backend Framework: ASP.Net,
5. Database: MS SQL

# Chapter 3

### **3 Overall Description**

#### **3.1 Product Perspective**

The current System in Pakistan Army for maintenance of equipment is manual and paper-based which is both slow and cumbersome. Users got to record each entry manually which in turn increases probability of human errors, search a number of ledgers for periodic maintenance of equipment and/or track workorders manually for feedback on the equipment sent for any repairs. All this cumbersome activity slows down the pace of the work and workload on the staff increases many folds. This lag is not affordable in any way keeping in view the modern and volatile battlefield situation.

The main intention of the project is to set up a system in form of web-based application that will automate the whole process of record keeping, entries into database, generation of workorders and notifications in advance for any periodic repairs required.

#### **3.2 Product Functions**

Following are the key functions of the Military Tactical Equipment Maintenance System (MTEMS):

##### **3.2.1 User Profiles**

1. MTEMS registers every user and maintain their records. Users are Commanding Officer, Quarter Master, Maintenance staff.
2. User login and authentication for access.

##### **3.2.2 Sensors Input**

1. Sensing the current meter reading of the vehicles before departure and just after arrival.
2. Integration of bar code reader for record of weapon's issuance/recollection.

##### **3.2.3 Alerts and Reports**

Automated alerts and reports generation for maintenance for periodic and other required maintenance.

### **3.2.4 External connectivity**

No external device can be connected to the Server/Database to avoid data breach

### **3.2.5 Login/Access Right**

MTEMS will allow users to login, based on their roles e.g. Commanding Officer as admin of the system.

## **3.3 Operating Environment**

OE-1: MTEMS will use IIS Server.

OE-2: MTEMS will be managed with MS SQL database management system.

OE-3: MTEMS will run on Personal Computers.

OE-4: The hardware, software and technology used should have following specifications:

- Operating System: Windows 10
- Capability to link on Intranet.
- Bluetooth for exchange of data between Sensors and Database system
- Capability to exchange information across the network.
- Processor with speed of 1 GHz or above
- Ability to take input from sensors
- Device needs to have minimum 8 GB of RAM

### **3.3.1 Technology Platform:**

#### **3.3.1.1 Front End:**

MTEMS's front-end would be developed as web-based, network enabled providing the users with the interface to get registered on the server, and use the system. Development tools/language include Bootstrap JQuery, HTML 5, CSS 3.

#### **3.3.1.2 Programming languages:**

1. C# is the backend language.

#### **3.3.1.3 Programming Environment**

1. Bootstrap
2. Backend Framework: ASP.Net MVC framework
3. Back-end Coding Tool: Visual Studio
4. SQL Server

#### **3.3.1.4 Database**

1. MS SQL

### **3.4 Design and Implementation Constraints**

C-1: Accuracy of the sensors like accelerometer to be determined.

C-2: Soldiers and staff lack skills in using the system.

C-3: Network enabled system.

C-4: Use of English language as the main methods for correspondence in the system.

Connectivity issue:

C-5: Bluetooth be used as medium for exchanging data between Sensors and Database

C-6: Cannot be employed in operational and exercise areas.

C-7: Operating System: Windows 10



### **3.5 User Documentation**

UD- version 1.0: Ultimate publication shall be complemented with a user manual to enlighten users how to use MTEMS. User documentation that would be delivered along with the final product.

- User manual

### **3.6 Assumptions and Dependencies**

We can list following assumptions and dependencies for our system as follows:

AS-1: System must be functional round the clock.

AS-2: Intranet connection, BUS.

AS-3: Kote NCO is required for handling the barcode reader for reading the codes at the time of issuance/recollection of weapons.

AS-4: The Basic assumption is that majority of the soldiers are not adapted to the use of hi-tech equipment so the complexity to be minimized.

DEP-1: MTEMS shall be entirely dependent upon the server for 24/7 access as our database system resides on the admin's system.

DEP-2: Soldiers and staff need to be thoroughly trained for attaining better result and performance.

# Chapter 4

## 4 Software Requirements Specification

### 4.1 System Features

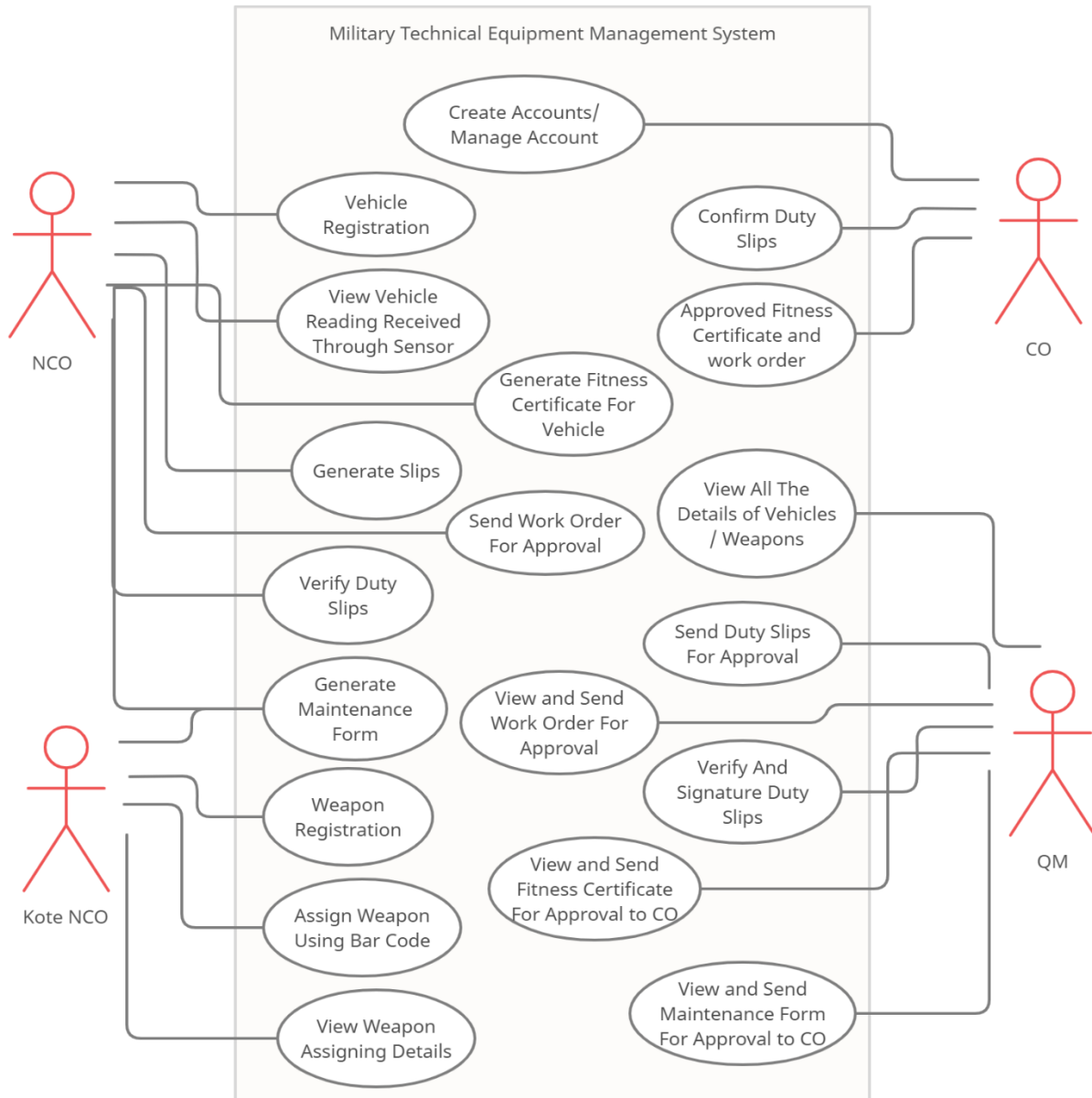

Figure 1-Use Case Diagram

#### 4.1.1 Use Case UC1: Create Account

Use Case ID:	1		
Use Case Name:	Create Account/ Manage Account		
Actors:	CO		
Created By:	Naqash Ali	Last Updated By:	Naqash Ali
Date Created:	19/03/2021	Date Last Updated:	19/03/2021
Description:	The CO will Create Account for NCO, KOTE NCO and QM and manage their account.		
Post conditions:	The account will be created successfully, and it will redirect it to the create account/ manage account page.		
Normal Flow (primary scenario):	<p>This use case starts when CO will Create Account for everyone.</p> <p>The system verifies the information which is delivered and stored it into the database.</p>		
Alternative Flows:	If the actor enters invalid information which is define by the parameter at the time of create account/manage account, the system displays an error message. The CO remains on the Create account/manage account page.		

**Table 1 Create Account**

#### 4.1.2 Use Case UC2: Confirm Duty Slip

Use Case ID:	2		
Use Case Name:	Confirm Duty Slip		
Actors:	CO		
Created By:	Naqash Ali	Last Updated By:	Naqash Ali
Date Created:	19/03/2021	Date Last Updated:	19/03/2021
Description:	The CO will sign the duty slip.		
Pre-Conditions:	The CO will be at the dashboard and goes into the Duty Slip request section.		
Post conditions:	The CO confirm the slip in the Duty Slip request section.		
Normal Flow (primary scenario):	This use case is used to accept and denied the Duty slip which is forwarded by the QM.		

**Table 2 Confirm Duty Slip**

#### 4.1.3 Use Case UC3: Fitness certificate and Workorders

Use Case ID:	3
--------------	---

Use Case Name:	Approved Certificate and Fitness Work Order:		
Actors:	CO		
Created By:	Naqash Ali	Last Updated By:	Naqash Ali
Date Created:	19/03/2021	Date Last Updated:	19/03/2021
Description:	The CO will approved the Fitness certificate and work order.		
Pre-Conditions:	The CO will be at the dashboard and goes into the approve Fitness Certificate and work Order Section.		
Post conditions:	The CO confirm and approve the fitness certificate and work order in the approve Fitness certificate and work order section.		
Normal Flow (primary scenario):	This use case is used to accept and denied the fitness certificate and also the work order which will then automatically forwarded to the QM.		

**Table 3 Fitness certificate and Workorders**

**4.1.4 Use Case UC4: View Details of vehicles and weapons**

Use Case ID:	4
Use Case Name:	View all Details of the Vehicles/ Weapons.

Actors:	QM		
Created By:	Naqash Ali	Last Updated By:	Naqash Ali
Date Created:	19/03/2021	Date Last Updated:	19/03/2021
Description:	The QM will login and redirected to the dashboard page and where it goes to the view all the Details of the Vehicles/ Weapons section to see the information.		
Pre-Conditions	The QM have to login to the system with all the correct information.		
Post conditions:	Once the forms is checked it will ready to forward to the superior.		
Normal Flow (primary scenario):	<p>This use case starts when QM log in to the system and redirected to the dashboard.</p> <p>The system verifies the given information and let the QM log in to the system where it can see the information and the form of all the vehicle and weapons in its assign section.</p>		

**Table 4 View Details of vehicles and weapons**

**4.1.5 Use Case UC5: Send Duty slip for approval**

Use Case ID:	5
Use Case Name:	Send Duty slip for approval.

Actors:	QM		
Created By:	Naqash Ali	Last Updated By:	Naqash Ali
Date Created:	19/03/2021	Date Last Updated:	19/03/2021
Description:	When the QM log in to the system it will be directed to the dashboard page where it will select the send duty slip section to see the day to day request and forwarded the duty slip for approval to the CO.		
Pre-Conditions	The QM have to login to the system with all the correct information.		
Post conditions:	Once the forms is checked it will ready to forward to the superior.		
Normal Flow (primary scenario):	<p>This use case starts when QM log in to the system and redirected to the dashboard.</p> <p>The system verifies the given information and let the QM log in to the system where it can see the information and the form of all Duty slip which is forwarded by the NCO in its assign section.</p>		

**Table 5 Send Duty slip for Approval**

#### **4.1.6 Use Case UC6: View and send work order for approval**

Use Case ID:	6
--------------	---



Use Case Name:	View and send work order for approval.		
Actors:	QM		
Created By:	Naqash Ali	Last Updated By:	Naqash Ali
Date Created:	19/03/2021	Date Last Updated:	19/03/2021
Description:	When the QM log in to the system it will be directed to the dashboard page where it will select the work order section to see the day-to-day request and forwarded the work order for approval to the CO.		
Pre-Conditions	The QM have to login to the system with all the correct information to redirect at the dashboard.		
Post conditions:	Once the forms is checked it will ready to forward to the superior.		
Normal Flow (primary scenario):	<p>This use case starts when QM log in to the system and redirected to the dashboard.</p> <p>The system verifies the given information and let the QM log in to the system where it can see the information and the form of all word order which is forwarded by the NCO and KOTE-NCO in its assign section and after confirming everything it will be forwarded to the CO.</p>		

**Table 6 View and send work order for approval**

#### **4.1.7 Use Case UC7: Verify and signature duty slip**

Use Case ID:	7		
Use Case Name:	Verify and signature duty slip.		
Actors:	QM		
Created By:	Naqash Ali	Last Updated By:	Naqash Ali
Date Created:	19/03/2021	Date Last Updated:	19/03/2021
Description:	When the QM goes to the duty slip section after verifying it the QM will signature the form and then it will be forwarded to the CO.		
Pre-Conditions	The QM will verify all the request for the duty slip in the dusty slip section.		
Post conditions:	Once the slips are verified and sign it will be forwarded to the CO.		
Normal Flow (primary scenario):	<p>This use case starts when QM go to the duty slip section.</p> <p>When the slip is verified and sign by the QM it will ready to be forwarded to the CO for approval.</p>		

**Table 7 Verify and signature duty slip**

**4.1.8 Use Case UC8: View and send fitness certificate for approval to CO**

Use Case ID:	8
--------------	---

Use Case Name:	View and send fitness certificate for approval to CO.		
Actors:	QM		
Created By:	Naqash Ali	Last Updated By:	Naqash Ali
Date Created:	19/03/2021	Date Last Updated:	19/03/2021
Description:	When the QM goes in to the Certificate section after verifying it the QM will signature the form and then it will be forwarded to the CO.		
Pre-Conditions	The QM will verify all the request for the Fitness Certificate in the Certificate section.		
Post conditions:	Once the Fitness Certificate are verify and sign it will be forwarded to the CO.		
Normal Flow (primary scenario):	<p>This use case starts when QM go to the Certificate section</p> <p>When the Fitness Certificate are verify and sign by the QM which is forwarded by the NOC it will ready to be forwarded to the CO for approval.</p>		

**Table 8 View and send fitness certificate for approval to CO**

#### 4.1.9 Use Case UC9: Vehicles Registration

Use Case ID:	9
--------------	---

Use Case Name:	Vehicles Registration.		
Actors:	NCO		
Created By:	Naqash Ali	Last Updated By:	Naqash Ali
Date Created:	19/03/2021	Date Last Updated:	19/03/2021
Description:	When the NCO log in to the system it will directed to the dashboard then after that the NCO will go into the vehicle section to register the vehicle and it will be stored into the database.		
Pre-Conditions	The QM has to fill out the specific field on the system to register the vehicle.		
Post conditions:	Once the vehicle is registered it will stored into the database.		
Normal Flow (primary scenario):	<p>This use case starts when NCO click the vehicle section which is on the Dashboard.</p> <p>Once the NCO register the vehicle then it can be allowed to leave the premises.</p>		

**Table 9 Vehicles Registration**

#### **4.1.10 Use Case UC10: View Vehicle Reading Received through Sensor**

Use Case ID:	10
--------------	----

Use Case Name:	View Vehicle Reading Received through Sensor.		
Actors:	NCO		
Created By:	Naqash Ali	Last Updated By:	Naqash Ali
Date Created:	19/03/2021	Date Last Updated:	19/03/2021
Description:	After the NCO log in to the system then it will be directed to the Dashboard for checking the reading it has to go into the vehicle reading section to check the reading of the vehicle which is received by the sensor.		
Pre-Conditions	The NCO will see that which vehicle is leave out of the premises which is recorded by the sensor so when it come back in to the premises it will received its reading either it's the same vehicle or not.		
Post conditions:	Once the reading is received to the NCO it will stored into the database.		
Normal Flow (primary scenario):	This use case starts when NCO click on the vehicle reading section.  Once the vehicle leave it will note down the specific information of the vehicle and when it comes back it will not down the reading through sensor of that specific vehicle which leave the premises.		

**Table 10 View Vehicle Reading Received through Sensor**

#### **4.1.11 Use Case UC11 : Generate Fitness Certificate for Vehicle**

Use Case ID:	11		
Use Case Name:	Generate Fitness Certificate for Vehicle.		
Actors:	NCO		
Created By:	Naqash Ali	Last Updated By:	Naqash Ali
Date Created:	19/03/2021	Date Last Updated:	19/03/2021
Description:	The NCO will generate Fitness Certificate for the Vehicle so it can be forwarded to the QM.		
Pre-Conditions	The NCO generate the fitness certificate before sending it to the QM.		
Post conditions:	Once the NCO fill out the form of fitness certificate for vehicle then it will be forwarded to the QM.		
Normal Flow (primary scenario):	<p>This use case starts when NCO generate the form from the Fitness Certificate section.</p> <p>The Fitness Certificate will be generated and send it to the QM for the approval once it is verify by the QM it will forwarded to the CO for final Approval.</p>		

**Table 11 Generate Fitness Certificate for Vehicle**

#### **4.1.12 Use Case UC12: Generate Duty slips**

Use Case ID:	12		
Use Case Name:	Generate Duty slips.		
Actors:	NCO		
Created By:	Naqash Ali	Last Updated By:	Naqash Ali
Date Created:	19/03/2021	Date Last Updated:	19/03/2021
Description:	The NCO will generate Duty slip by filling out the specific fields.		
Pre-Conditions	The NCO will be filling out the specific fields of the duty slip in the duty slip section.		
Post conditions:	Once the duty slip is generated it will be send it to the QM for the approval.		
Normal Flow (primary scenario):	<p>This use case starts when NCO goes into the Duty slip section.</p> <p>The duty slip will be generated by the NCO and then send it to the QM for the approval and after that QM will forwarded THE Duty slip to CO for final approval.</p>		

**Table 12 Generate Duty slips**

#### **4.1.13 Use Case UC13: Send work order for approval**

Use Case ID:	13		
Use Case Name:	Send work order for approval.		
Actors:	NCO		
Created By:	Naqash Ali	Last Updated By:	Naqash Ali
Date Created:	19/03/2021	Date Last Updated:	19/03/2021
Description:	The NCO will generate work order and forwarded it to QM for approval.		
Pre-Conditions	The NCO need to generate the work order for approval.		
Post conditions:	Once the work order is generated it will forwarded to the superiors for the approval.		
Normal Flow (primary scenario):	<p>This use case starts when NCO goes into the dashboard by log in to the system.</p> <p>Once the work order is generated it will be send it to the QM for verification and signature once it's done then the duty slip forwarded to the CO for final Approval.</p>		

**Table 13 Send work order for approval**

**4.1.14 Use Case UC14: Verify Duty Slip**



Use Case ID:	14		
Use Case Name:	Verify Duty Slip.		
Actors:	NCO		
Created By:	Naqash Ali	Last Updated By:	Naqash Ali
Date Created:	19/03/2021	Date Last Updated:	19/03/2021
Description:	The NCO will verify the Duty slip after that the vehicle will be considered is verified through the system.		
Pre-Conditions:	The Duty slip is approved from QM and CO.		
Post conditions:	Once the duty slip is verified the vehicle can leave the premises because it is approved by the superiors.		
Normal Flow (primary scenario):	<p>This use case starts when NCO go to the Verify duty slip section.</p> <p>When the vehicle leaves the premises, the sensor detect the vehicle and it will update the NOC that the vehicle is verified or not if any of the superior did not approved the vehicle it will be mentioned as unverified.</p>		
Alternative Flow:	In case of emergency the Duty slip will be generated but it will not be approved in the specific time so when the vehicle leaves the premises it will be considered unverified vehicle.		

**Table 14 Verify Duty Slip**

**4.1.15 Use Case UC15: Generate maintenance form**

Use Case ID:	15		
Use Case Name:	Generate maintenance form		
Actors:	NCO		
Created By:	Naqash Ali	Last Updated By:	Naqash Ali
Date Created:	19/03/2021	Date Last Updated:	19/03/2021
Description:	The NCO will generate maintenance form so it can be forwarded to the QM.		
Pre-Conditions	The NCO generate the maintenance form before forwarding to the QM.		
Post conditions:	Once the NCO fill out the form of maintenance form for vehicle then it will be forwarded to the QM.		
Normal Flow (primary scenario):	<p>This use case starts when NCO generate the form from the maintenance form section.</p> <p>The maintenance form will be generate and send it to the QM for the approval once it is verify by the QM it will forwarded to the CO for final Approval.</p>		

**Table 15 Generate maintenance form**

**4.1.16 Use Case UC16: Generate Maintenance form**

Use Case ID:	16		
Use Case Name:	Generate Maintenance form		
Actors:	KOTE-NCO		
Created By:	Naqash Ali	Last Updated By:	Naqash Ali
Date Created:	19/03/2021	Date Last Updated:	19/03/2021
Description:	The KOTE-NCO will generate maintenance form so it can be forwarded to the QM.		
Pre-Conditions	The KOTE-NCO generate the maintenance form before forwarding to the QM.		
Post conditions:	Once the KOTE-NCO fill out the form of maintenance form for Weapons then it will be forwarded to the QM.		
Normal Flow (primary scenario):	<p>This use case starts when KOTE-NCO generate the form from the maintenance form section.</p> <p>The maintenance form will be generated and send it to the QM for the approval once it is verify by the QM it will forwarded to the CO for final Approval.</p>		

**Table 16 Generate Maintenance form**

**4.1.17 Use Case UC17: Weapon Registration**

Use Case ID:	17		
Use Case Name:	Weapon Registration.		
Actors:	KOTE-NCO		
Created By:	Naqash Ali	Last Updated By:	Naqash Ali
Date Created:	19/03/2021	Date Last Updated:	19/03/2021
Description:	When the KOTE-NCO log in to the system it will directed to the dashboard then after that the KOTE-NCO will go into the Weapon section to register the weapon and it will stored into the database.		
Pre-Conditions	The QM have to fill out the specific field on the system to register the Weapon.		
Post conditions:	Once the weapon is registered it will stored into the database.		
Normal Flow (primary scenario):	<p>This use case starts when KOTE-NCO click the Weapon section which is on the Dashboard.</p> <p>Once the KOTE-NCO register the weapon then its data will be save in the database.</p>		

**Table 17 Weapon Registration**

#### 4.1.18 Use Case UC18: Assign Weapon using Bar code

Use Case ID:	18		
Use Case Name:	Assign Weapon using Bar code		
Actors:	KOTE-NCO		
Created By:	Naqash Ali	Last Updated By:	Naqash Ali
Date Created:	19/03/2021	Date Last Updated:	19/03/2021
Description:	When every the KOTE-NCO assign weapon to anyone it is already registered in to the database so at the time of assigning the bar code is used to issue the weapons.		
Pre-Conditions	The weapons should be registered in the database to before assigning to anyone.		
Post conditions:	Once it issued through the bar code it will save the data into the database that which weapon is assign to whom.		
Normal Flow (primary scenario):	<p>This use case starts when KOTE-NCO log in and directed to the dashboard where it goes to the assigning weapons section.</p> <p>When the KOTE-NCO need to assign the weapon to anyone it just have to put the data of the person whom the weapon is assign and the weapon will be issue using the bar code so the information will be save that which weapon is assign to which person.</p>		

**Table 18 Assign Weapon using Bar code**

**4.1.19 Use Case UC19: View Weapons Assigning Details**

Use Case ID:	19		
Use Case Name:	View Weapons Assigning Details.		
Actors:	KOTE-NCO		
Created By:	Naqash Ali	Last Updated By:	Naqash Ali
Date Created:	19/03/2021	Date Last Updated:	19/03/2021
Description:	When every the KOTE-NCO issue the weapons to anyone its regarding information is save at the time of assigning weapons section. So in the view Weapon section the assigning details can be seen that for how many time the weapons is assign and to whom.		
Pre-Conditions	The weapons should be assign to someone before it comes to view weapons section.		
Post conditions:	Once it issued through the bar code it will save the data into the database that which weapon is assign to whom.		
Normal Flow (primary scenario):	<p>This use case starts when KOTE-NCO log in and directed to the dashboard where it goes to the view weapons section.</p> <p>When the KOTE-NCO assign the weapon to anyone so it's regarding information is saved in the database so in this section it</p>		

	<p>can be seen. If someone time is finished which is allotted at the time of assigning the weapon it will give an error of that weapon to re-register the weapon.</p>
--	---

**Table 19 View Weapons Assigning Details**

## 4.2 Other Non-functional Requirements

### 4.2.1 Performance Requirements

- Application ought to be light weight.
- The front-page load time must be no more than 5 seconds.
- PC with 8 GB RAM must be able to run the application.

### 4.2.2 Safety Requirements

- Application shall handle any user's information safely.
- Only registered users can login to the system.
- User credentials and private info shall not be shared with the rest of the users.

### 4.2.3 Security Requirements

- Only Commanding Officer can modify user profiles.
- The system shall not be accessed by any unauthorized person.
- USB ports of the system shall be disabled.

### 4.2.4 Software Quality Attributes

- **Availability:** System shall be operating round the clock.
- **Reusability:** The components of the system are reusable.
- **Reliability:** Failure rate be minimized for reliable performance.

#### **4.2.5 Business rules:**

- Standard Operating procedures are already laid down in Army for maintenance of equipment that shall be adhered with
- All operations of the system shall be governed by these rules or procedures.

### **4.3 Software Quality Attributes**

Quality attributes of MTEMS are portrayed underneath. In the wake of these characteristics, the quality of MTEMS shall be enhanced.

#### **4.3.1 Runtime System Qualities**

Some of the qualities that needs to be counted in the development of MTEMS are described here.

##### **4.3.1.1 Functionality**

MTEMS must provide functions to search the different vehicles and equipment and the reports. MTEMS ought to offer the feature of authentication of user.

##### **4.3.1.2 Availability**

MTEMS should be available round the clock. If at all system is down, the servers will take about 5 minutes to start the MTEMS again.

##### **4.3.1.3 Usability**

Usability is an important criterion in the development of MTEMS. The system should present all functionalities in such a way that nothing is missed by the user. The app will be presented and organized in a manner that is both visually appealing and easy for the user to navigate.

##### **4.3.1.4 Non-Runtime System Qualities**

These are characteristics of MTEMS which are required to make this software useful for further enhancements. It will also be helpful in future development as well as extending system to different environments.



#### **4.3.1.5 Modifiability**

MTEMS ought to support modifiability in case any further enhancements or features are effortless to incorporate.

#### **4.3.1.6 Testability**

Various quality assessments ought to be executed so that MTEMS is exempt of flaws and operate as required.

# Chapter 5

## 5 System Design Specifications

### 5.1 System Architectural Design

Layered architecture will be used with each layer providing a set of functionalities. These layers will be composed of multiple services which will communicate with each other via message passing. Abstractly, the services can be observed as components of the complete solution. Though, on the inside, each facility is made up of software components, exactly as any other application, additionally these components can make use of each other without being aware of the internal implementation.

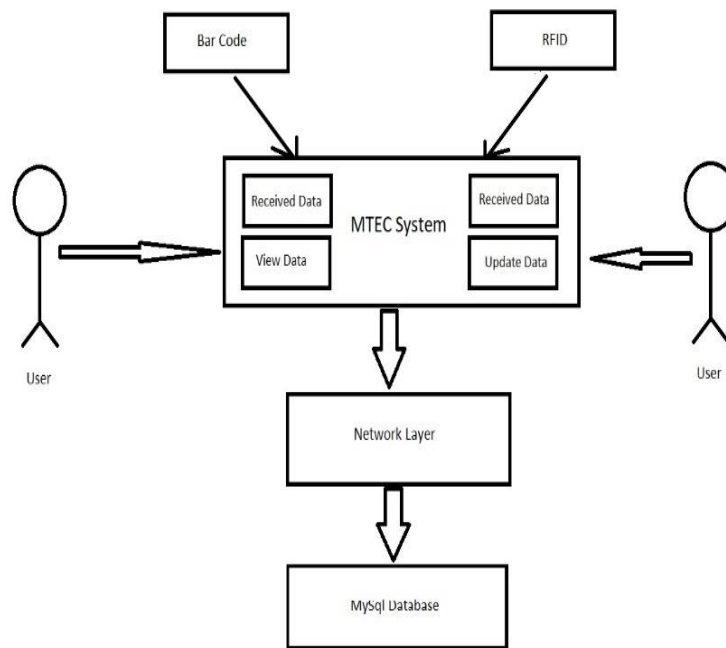

---

**Figure 2 System Architecture**

#### 5.1.1 Presentation Layer

This layer act as a manifesto for the communication of the user and system. This layer presents data to the user and recognizes input from the user.

### 5.1.2 Business Logic

It provides the core functionality to application which a user is required to have from the application.

### 5.1.3 Data Access Layer

This layer entertains the request from the Service Layer and sends report back data after querying from the database server.

## 5.2 Class Diagram

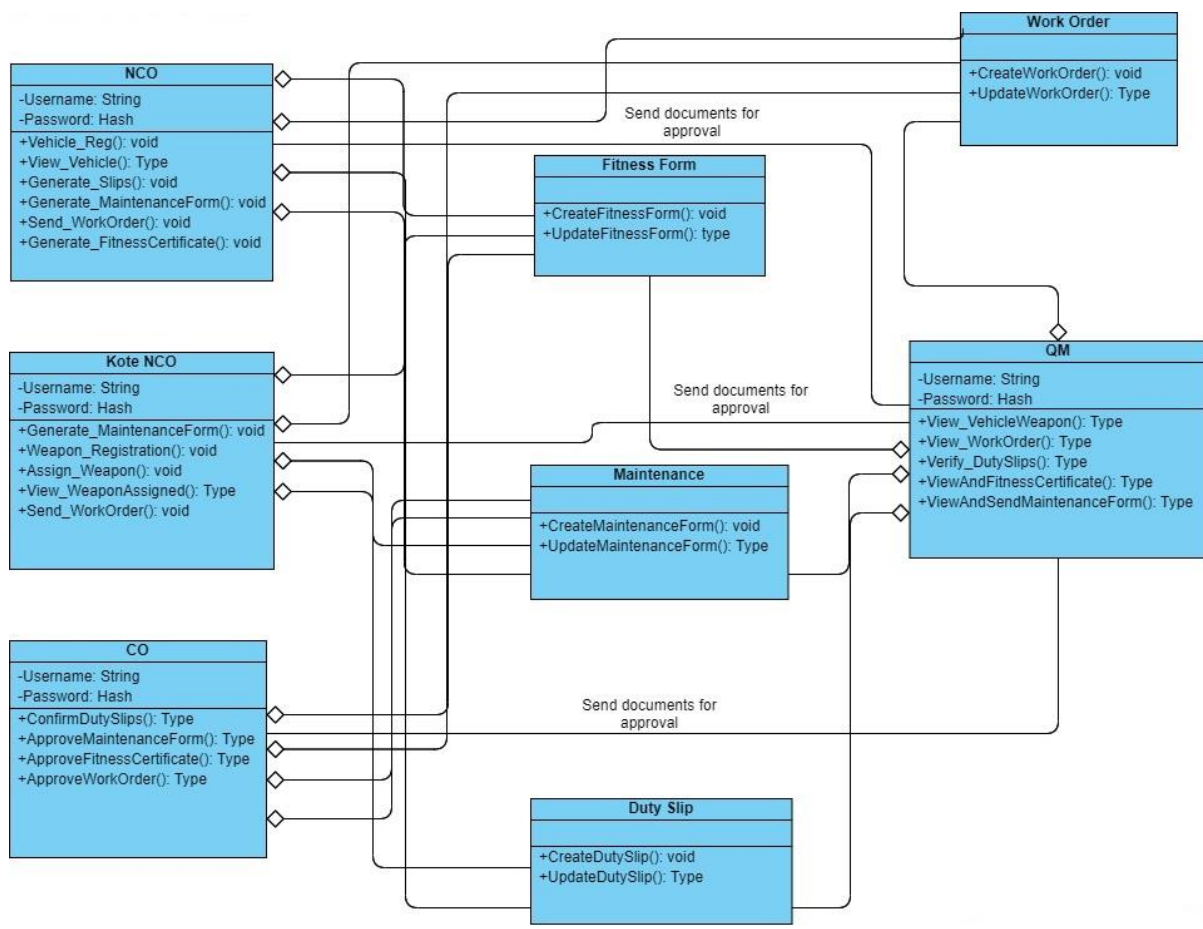
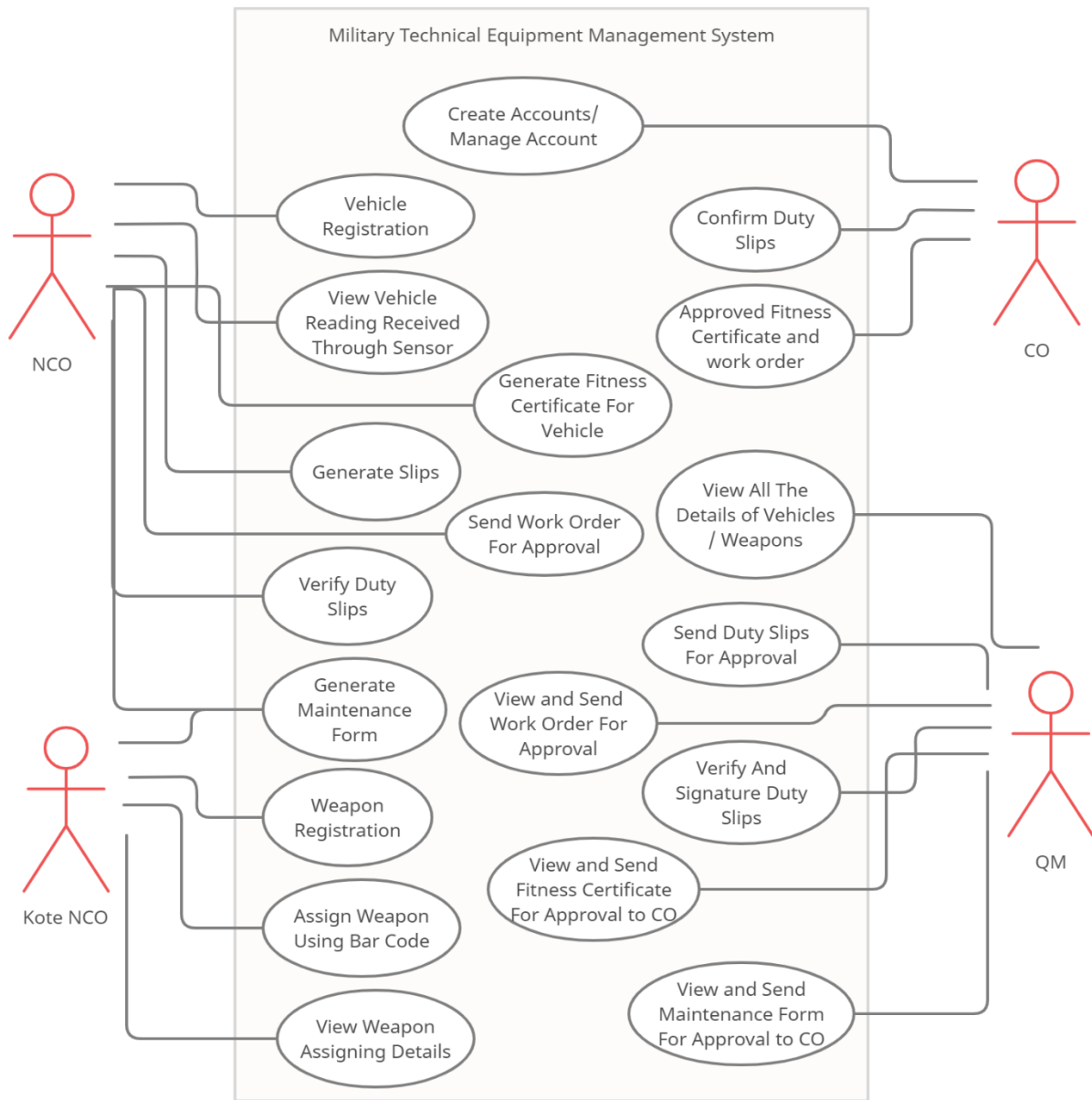

Figure 3 Class Diagram

### 5.3 Use Case Diagram



**Figure 4 Use Case Diagram**

## 5.4 Sequence Diagrams

### 5.5 Login-Success & Failure:

The below diagram defines the sequence of actions that happens when end User tries to login into the system.

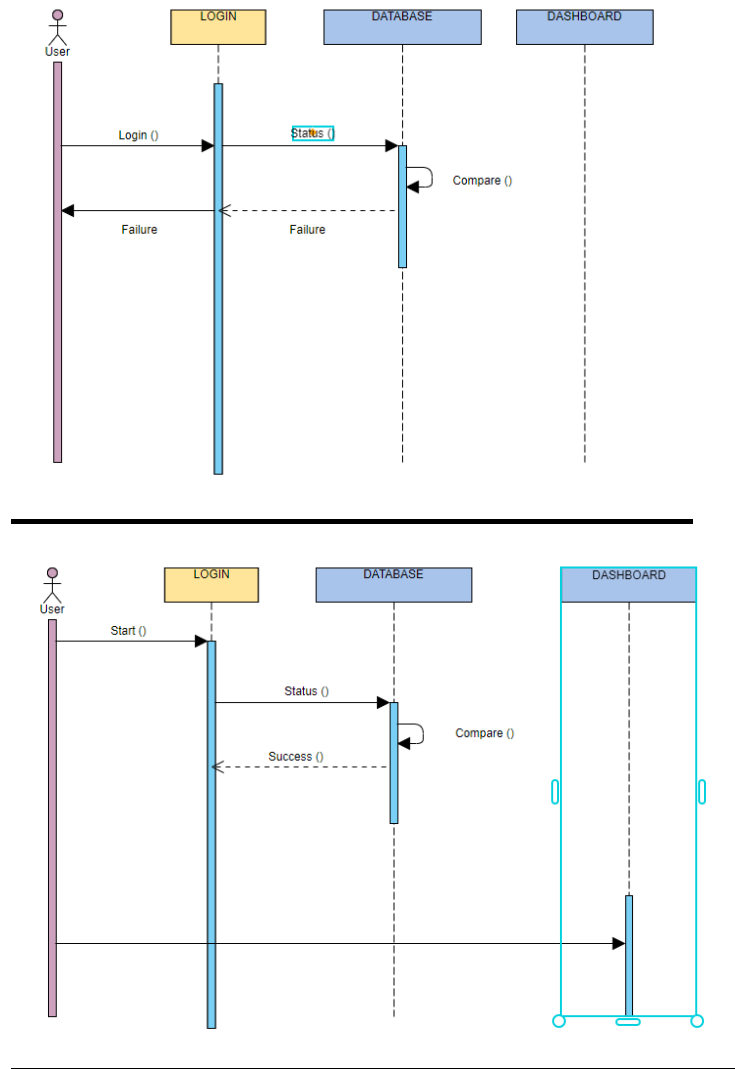
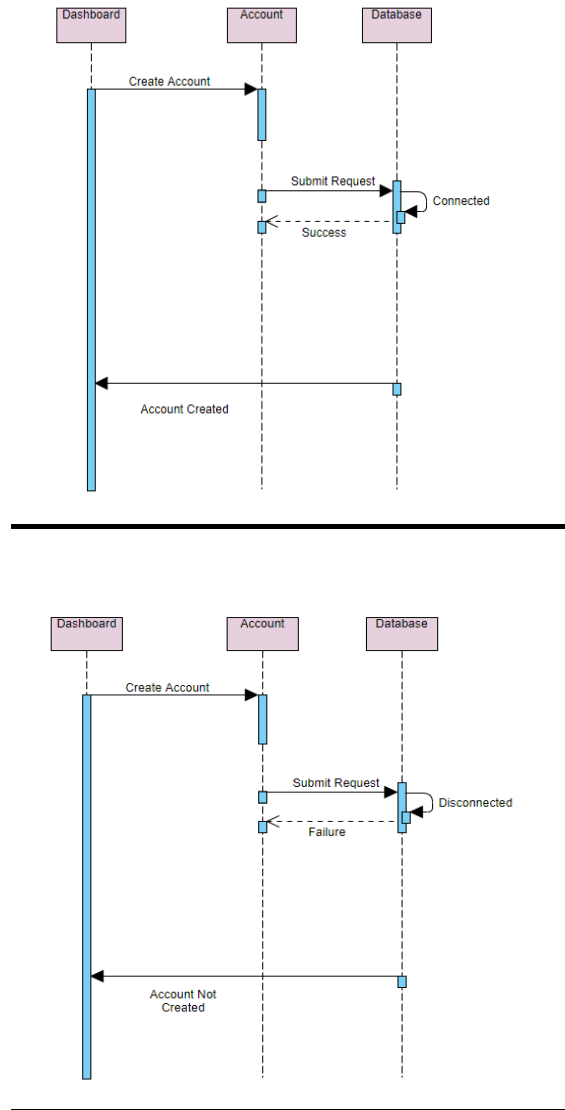

Figure 5 Sequence Diagram Login

### 5.5.1 Account Creation Success & Failure:

The below diagram defines the sequence of actions that happens when an account is created for the end-user.



**Figure 6 Account Creation Success & Failure**

## 5.5.2 Duty Slips Success & Failure

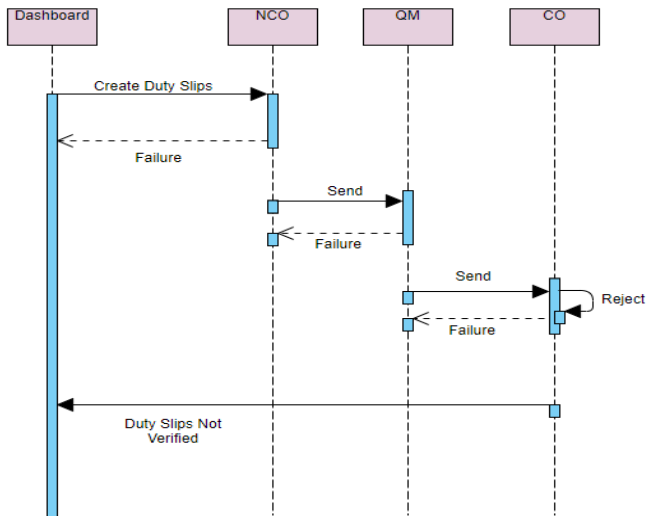
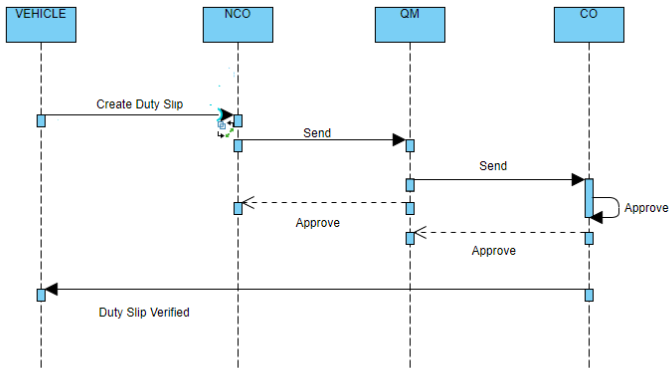

Figure 7 Sequence diagram Duty Slips Success & Failure



### 5.5.3 Maintenance Form Success & Failure

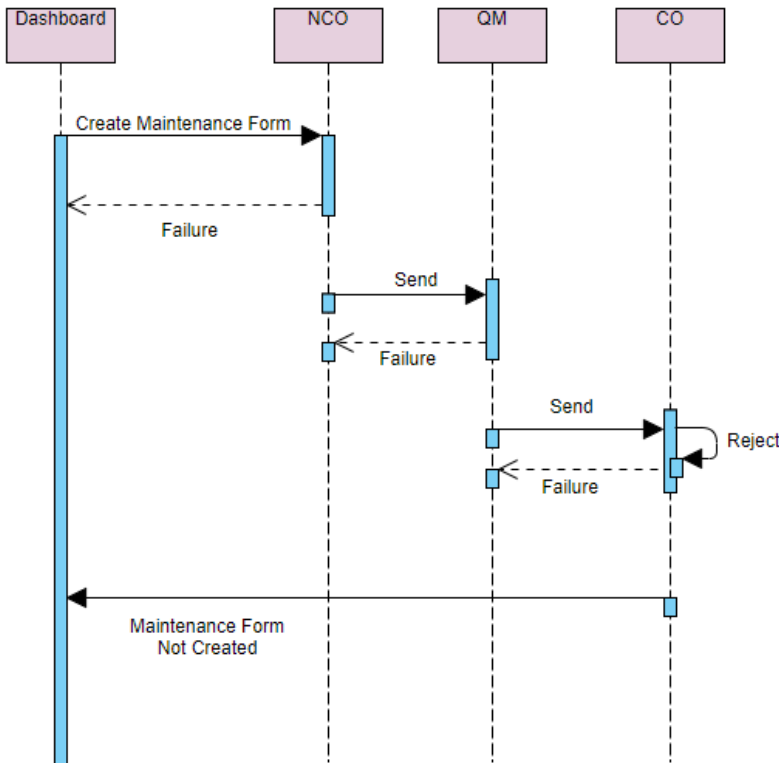
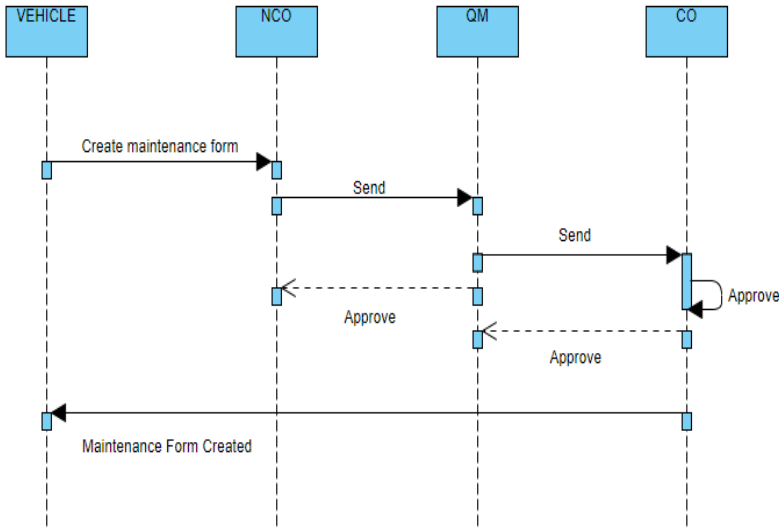

Figure 8 Sequence diagram Maintenance Form Success & Failure

### 5.5.4 Work Order Success & Failure

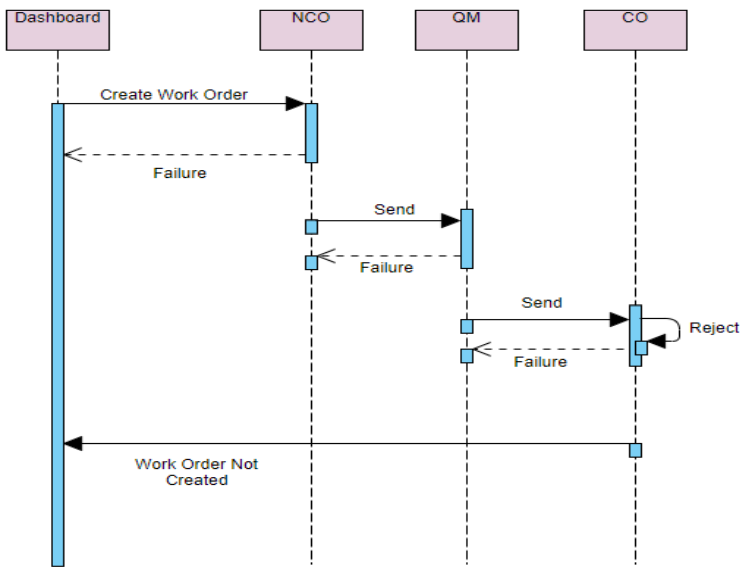
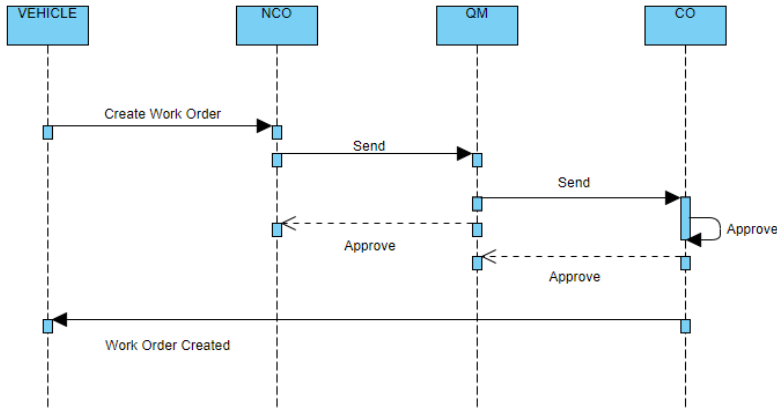

Figure 9 Sequence Diagram Work Order Success & Failure

### 5.5.5 Fitness Certificate Success & Failure

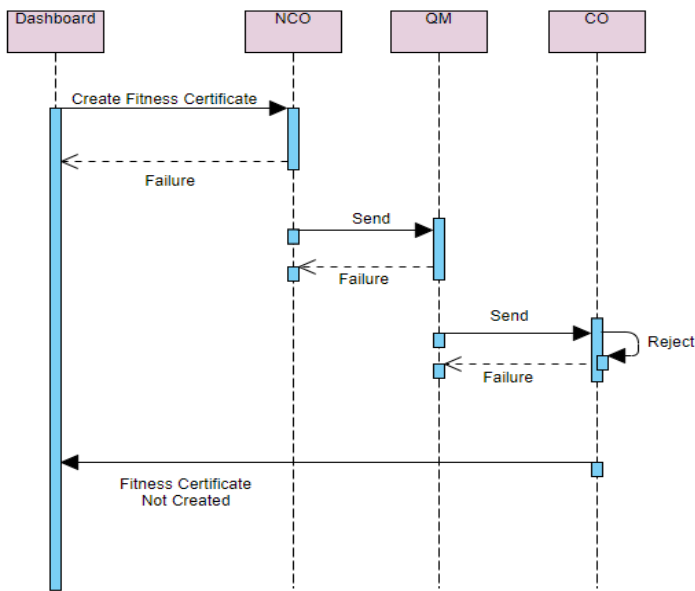
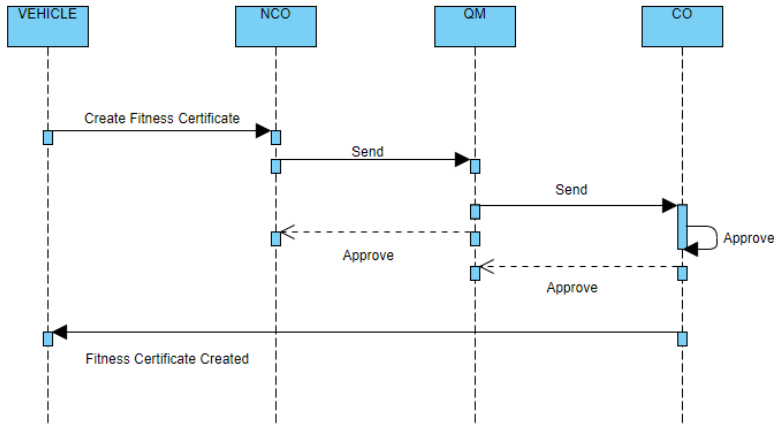

Figure 10 Sequence Diagram Fitness Certificate Success & Failure

## 5.5.6 Assign Weapon

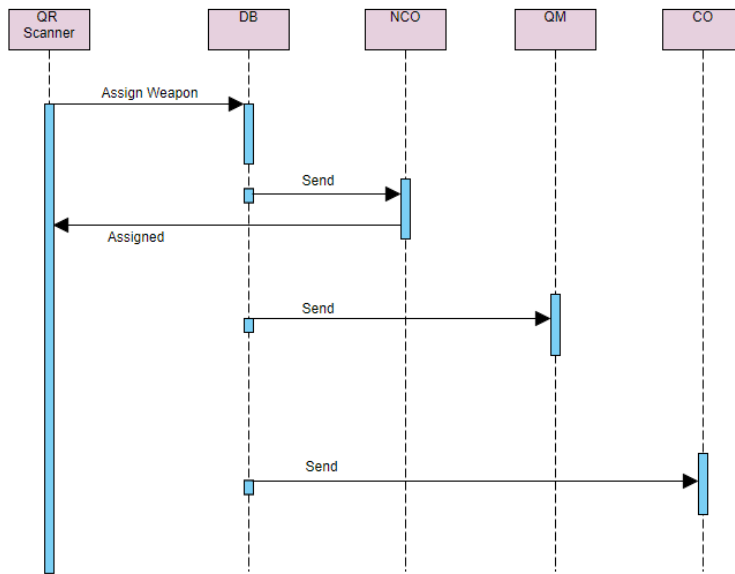
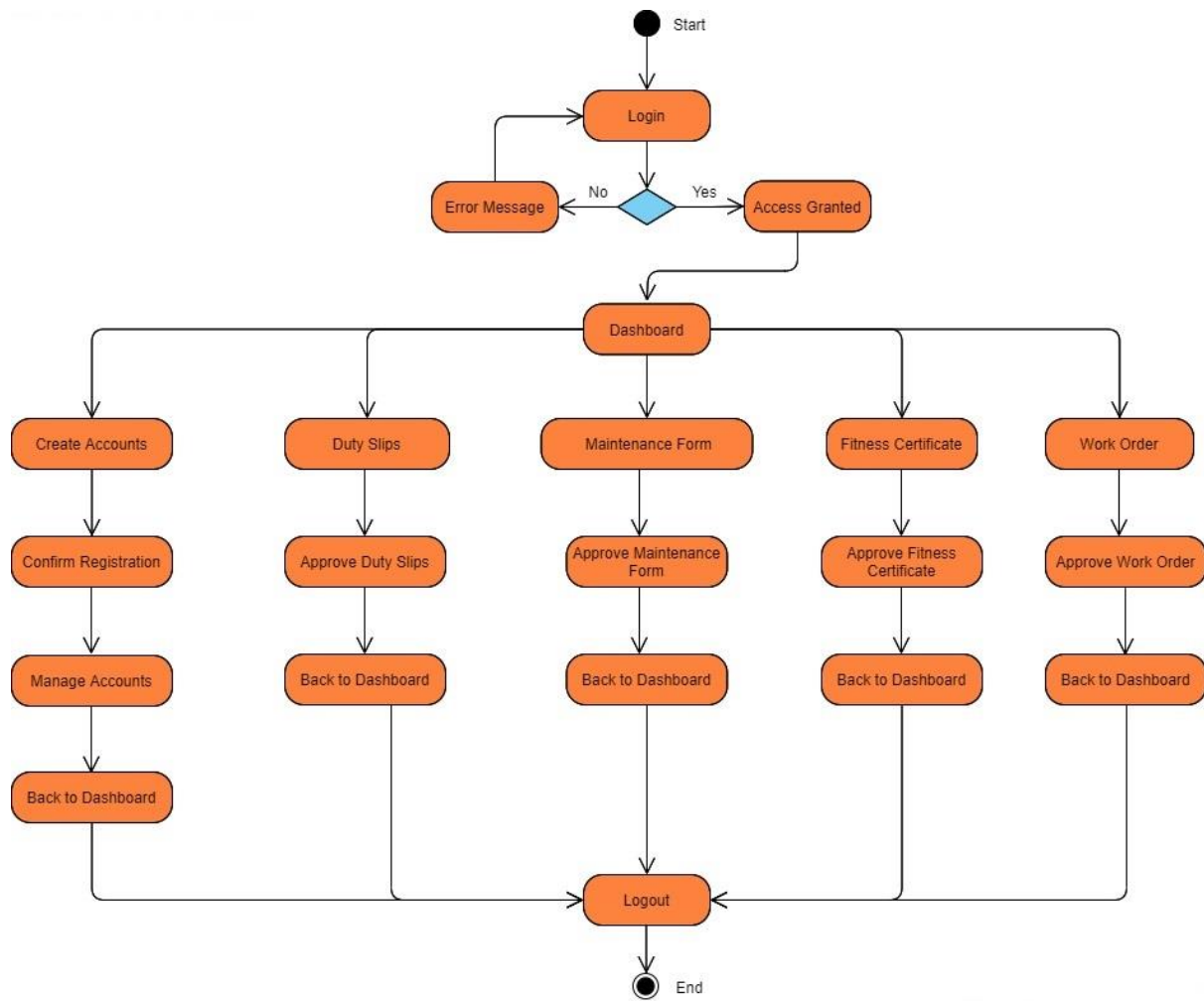

Figure 11 Sequence diagram Assign Weapon

## 5.6 Activity Diagrams

The activity diagram below depicts the full range of activities that a user can perform. To use the System, a user must first log in.

### 5.6.1 Activity Diagram - CO:



**Figure 12 Activity Diagram: Activity Diagram - CO**

### 5.6.2 Activity Diagram – QM:

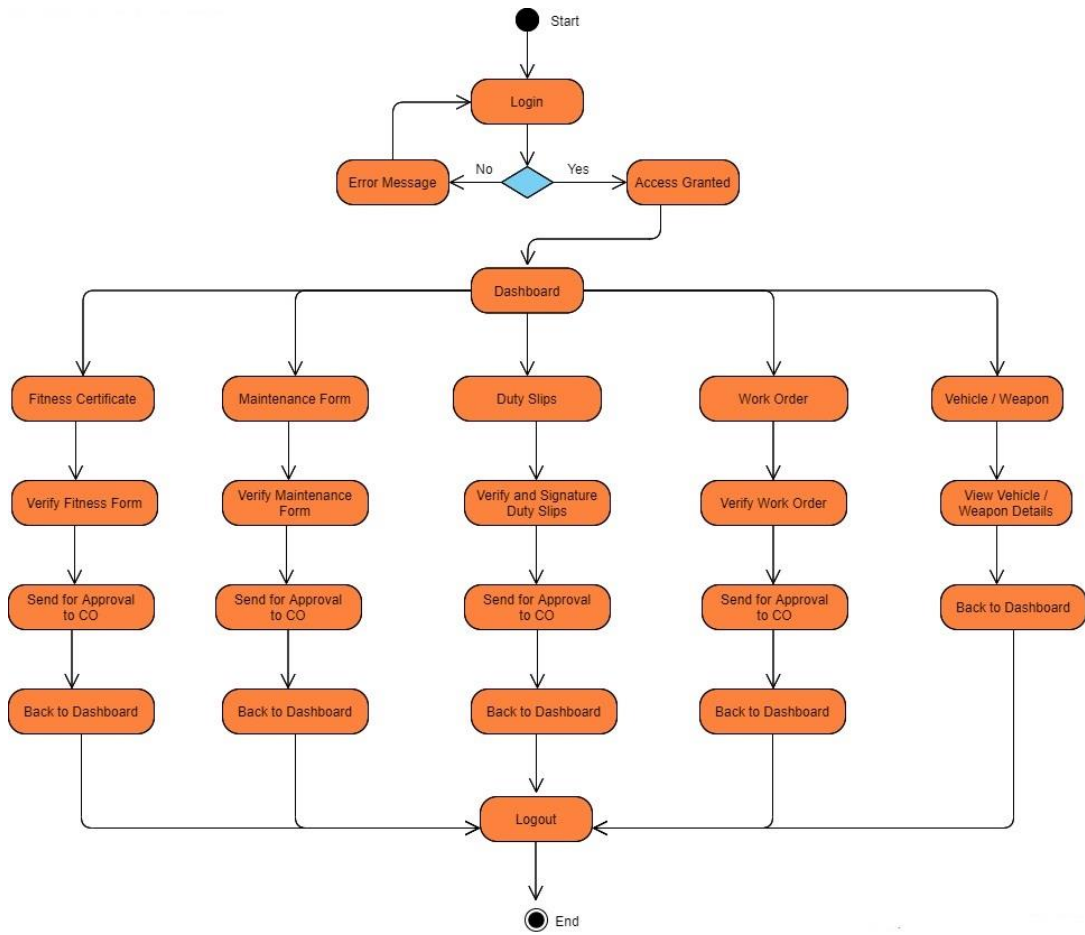

**Figure 13 Activity Diagram: Activity Diagram – QM**

### 5.6.3 Activity Diagram – KOTE NCO

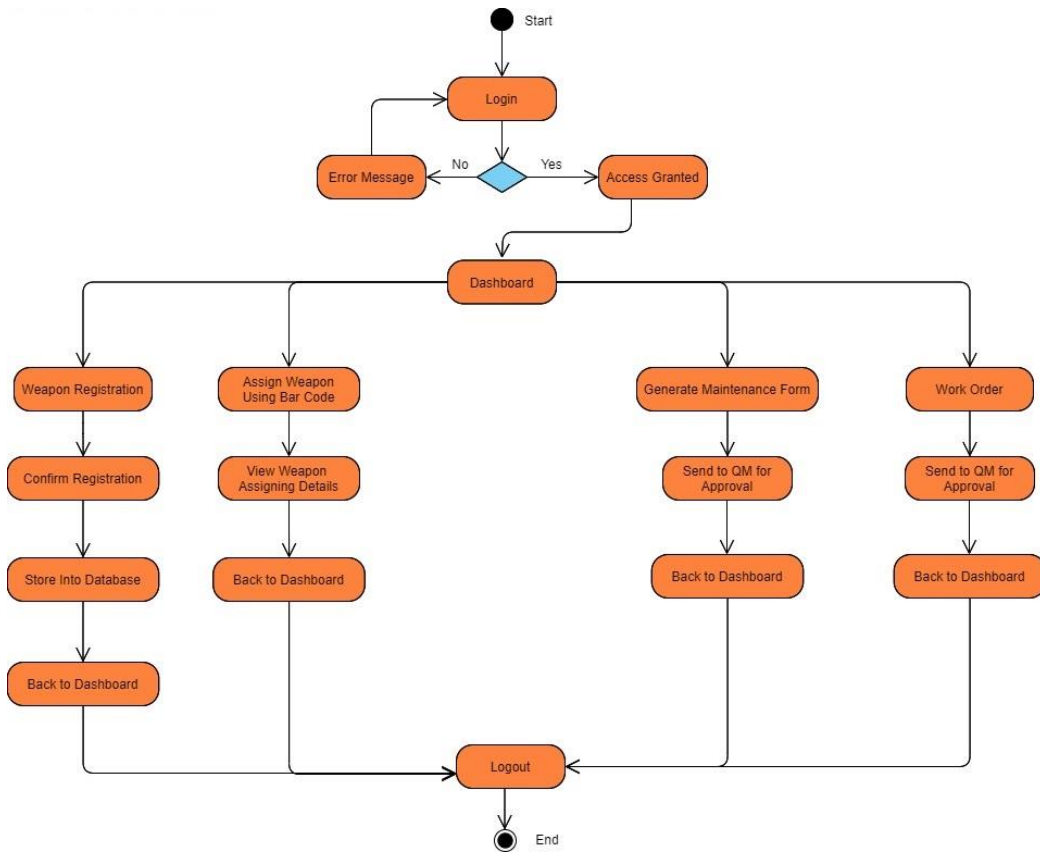

Figure 14 Activity Diagram - KOTE NCO

## 5.6.4 Activity Diagram – NCO

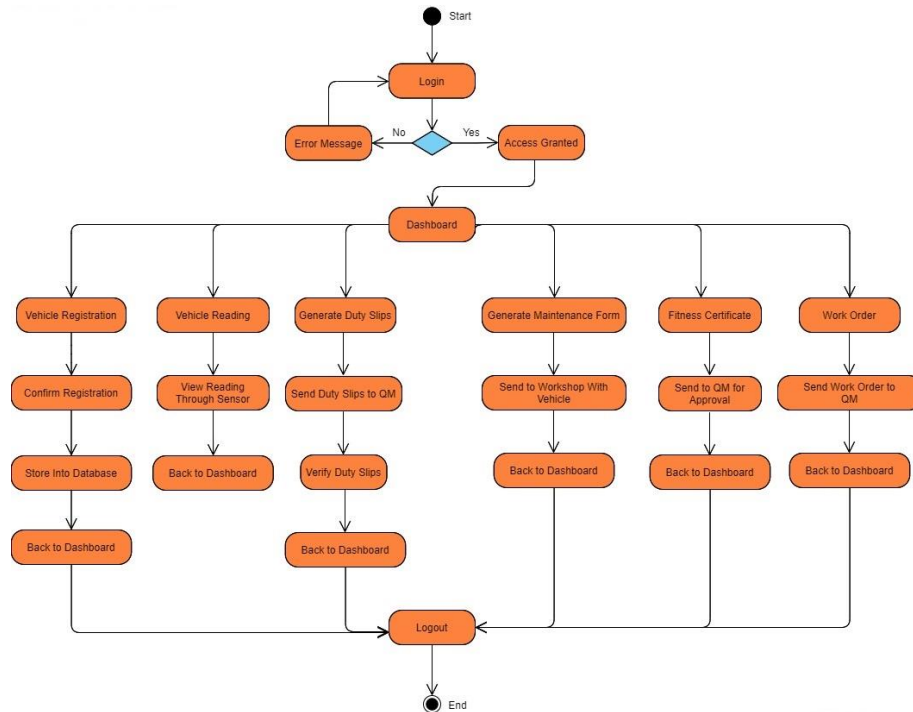

Figure 15 Activity Diagram: Activity Diagram – NCO

## 5.7 Design Rationale

The layered architecture design is a strong broadly useful example, making it a decent beginning stage for most applications, especially when you don't know what architecture design is most appropriate for your application. In any case, there are a few interesting points from architecture design viewpoint while picking the pattern.

The main thing to keep an eye out for is what is known as the architecture sinkhole anti-pattern. This anti-pattern depicts the circumstance where solicitations course through different layers of the design as straightforward go through preparing with practically zero rationale performed inside each layer. For instance, accept the introduction layer reacts to a solicitation from the client to recover client information. The introduction layer passes the solicitation to the business layer, which essentially passes the solicitation to the constancy layer, which at that point makes a basic SQL call to the database layer to



recover the client information. The information is then passed right back up the stack with no extra handling or rationale to total, compute, or change the information.

Each layered architecture will have probably a few situations that fall into the design sinkhole hostile to design. The key, be that as it may, is to examine the level of solicitations that fall into this classification. The 80-20 standard is normally a decent practice to follow to decide if you are encountering the design sinkhole against design. It is commonplace to have around 20 percent of the solicitations as straightforward go through preparing and 80 percent of the solicitations having some business rationale related with the solicitation. In any case, if you find that this proportion is switched, and a dominant part of your solicitations are basic go through handling, you should consider making a portion of the design layers open, remembering that it will be progressively hard to control change because of the absence of layer confinement.

Another thought with the layered design is that it will in general lean itself toward solid applications, regardless of whether you split the introduction layer and business layers into isolated deployable units. While this may not be a worry for certain applications, it represents some expected issues as far as sending, general strength and dependability, execution, and versatility.

## **5.8 Component Design**

We gave an Object-Oriented description in section 5.7 and summarized each object member function in all the objects created.

# Chapter 6

## **6 System Implementation**

### **6.1 Technology Used**

#### **6.1.1 Programming Language Used**

MS SQL database has been used for handling all the data storing, retrieval and fetching that is used to operate the application. The web-based application for the project was written using ASP.Net, MVC and SQL Server.

#### **6.1.2 Development Tools**

Application is developed using Visual Studio and SQL Server.

#### **6.1.3 Database**

The systems Database is designed and maintained using IIS Server.

#### **6.1.4 Operating System**

Windows 10 will be required for the systems running the application.

### **6.2 Complete System Implementation**

The system comprises of four components. A web-based application in which separate modules are designed for CO (Admin), QM (middle admin), and user i.e NCO and Kote-NCO. The major modules of the application will be discussed in detail in the succeeding sections.

#### **6.2.1 Login Page**

Given that the application shall be used by Admin or user they have to login first. This is used to access all the different functionality of the application and can be considered as a main menu.

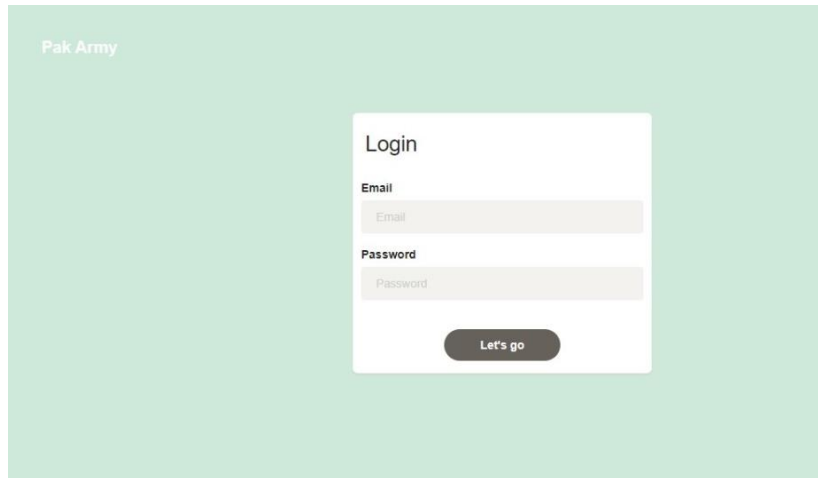

**Figure 16 Login Page**

### 6.2.2 Creating Account

This is the module designed for CO to create accounts like QM, NCO and kote-NCO who will be using the system as end users, users will have different permission and interface depending upon their roles.

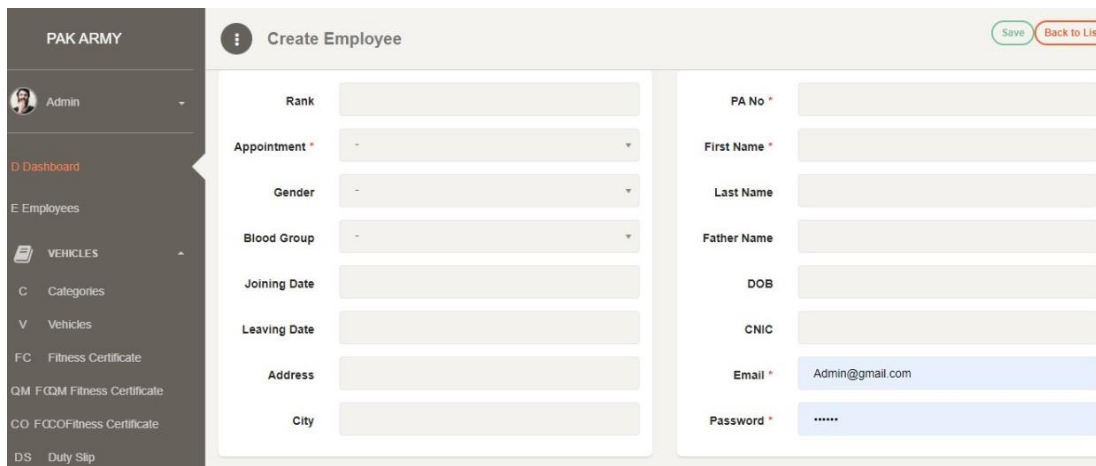

**Figure 17 Creating Account**

### 6.2.3 View Listed users

This module allows logged in users to view the complaints that they have lodged and view the development that has taken place for those specific complaints. It does so by seeing the tracking Id's connected with the account currently logged in to the application, then shows these. Upon selecting one, the details of that complaint are showed.

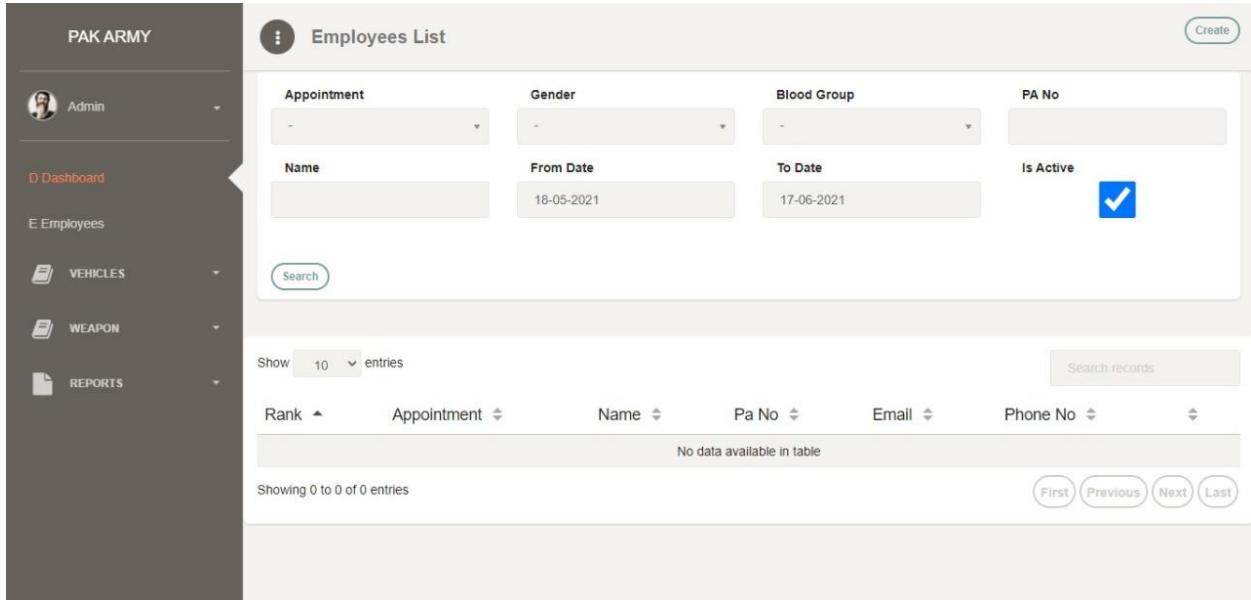

**Figure 18 View Listed users**

### 6.2.4 Register New Vehicles/ Weapons

Users can register new vehicles/weapons, which will be entered into database.

PAK ARMY
⋮ Create Vehicles
Save Back to List

Admin

D Dashboard

E Employees

VEHICLES

WEAPON

REPORTS

Category \* -

Maker Company

Model

Notes

Height

Width

Length

Weight

Image Path  No f...sen

BA Number \*

Name \*

Oil Change Date 17-06-2021

Oil Change Running

Battery Change Date 17-06-2021

Battery Change Running

Tyre Change Date 17-06-2021

Tyre Change Running

Consumption Avg

PAK ARMY
⋮ Create Weapons
Save Back to List

Admin

D Dashboard

E Employees

VEHICLES

WEAPON

REPORTS

Category \* -

Butt Number \*

Maker Company

Model

Body # \*

Name \*

Notes

**Figure 19 Register New Vehicles/ Weapons**

## 6.2.5 Fitness certificate/ Duty Slip

**PAK ARMY** Create Duty Slip Save Back to List

Category \* -

STO Indent Register No \*

Indenting Unit \*

The following will report as under -

At

To Proceed To

From Date \* 17-06-2021

BA Number \* -

Dated \* 17-06-2021

Rationed To

Notes \*

Nature and probable duration of duty

Via (Route)

To Date \* 17-06-2021

**PAK ARMY** Create Fitness Certificate Save Back to List

Category \* -

Make And Type \*

Remarks \*

Vehicle \* -

Date \* 17-06-2021

Figure 20 Fitness certificate/ Duty Slip

# Chapter 7



## 7 System Implementation

### 7.1 Overview

Testing of software project include different levels of testing to ensure that the software which is being developed is free of errors and faults. The different levels at which testing was performed is argued here.

### 7.2 Unit Testing

It includes the testing of each module at completion.

#### 7.2.1 Login Feature Testing

<b>Test Case Name:</b>		<b>System Login Testing</b>	
<b>Test Case ID:</b>	01		
<b>Description of Case</b>	This module enables user to login to the system by providing his credentials. As per the sequence of authorization the credentials are checked with the database, noted that access shall be granted only to verified credentials.		
<b>Testing technique used:</b>	Black Box Testing		
<b>Preconditions:</b>	System operating normally and connectivity of system and database is already established.		
<b>Input values:</b>	Username: String		

	Password/PIN: String	
<b>Valid Inputs:</b>	Registered Users/legal Users credentials Registered password/legal password	
<b>Steps</b>	<ol style="list-style-type: none"> <li>1. Enter username</li> <li>2. Enter password</li> <li>3. Click SIGN IN</li> </ol>	
<b>Expected Output</b>	After successful verification of the user credentials from the database, the user shall be directed to the dashboard.	
<b>Actual Output</b>	User logged in successfully.	
<b>Status</b>	POSITIVE/PASS	

**Table 20 System Login Testing**

### 7.2.2 Creating Account feature Testing

<b>Test Case Name:</b>	<b>Creating Account Module testing</b>
<b>Test Case ID:</b>	02
<b>Description:</b>	This module shall enable System Admin (Commanding Officer) to register the users by providing their credentials. As per the sequence of registration the credentials are stored within the database, noted that access shall be granted based on these credentials.

<b>Testing technique used:</b>	Black Box Testing	
<b>Preconditions:</b>	System shall be operating normally, and connectivity of system and database is already established.	
<b>Input values:</b>	First Name	
	Last Name	
	ID	
	Password	
<b>Valid Inputs:</b>	First Name Type: String	
	Last Name Type: String	
	Password Type: Alphanumeric	
<b>Steps</b>	1. Enter First Name	
	2. Enter Last Name	
	3. Enter ID	
	4. Enter Password	
	5. Tap Register/Create account button	
<b>Expected Output</b>	Credentials provided by admin shall be stored at the database.	
<b>Actual Output</b>	Credentials provided by admin are stored in database.	

<b>Status</b>	PASS/POSITIVE
---------------	---------------

**Table 21 Creating Account Feature Testing**

# Chapter 8

## **8 Conclusion and Future Work**

### **8.1 Conclusion**

Our goal was to develop a system to find out innovative and creative solution for military staff deputed to maintain the military tactical equipment available in the unit. A system needs to be developed that will allow staff an easy interface to work with, that will reduce their fatigue and effort, and will be a faster and reliable system to replace the existing paper based slow and cumbersome system.

We accomplished our objectives, successfully developing a web-based application that lets users keep record of the daily use of equipment, automatically generated alerts and notifications reduce their effort of searching huge ledgers to check for periodic maintenance of equipment, and reports can also be generated that help the staff see the current status of serviceable equipment.

Due to constraints of time and team size, the scope of the project was kept small. Initially we will deploy the system in one unit, but its scope can be enhanced with the passage of time.

We firmly believe that our project can genuinely bring about a significant change in the unit's routine maintenance tasks.

### **8.2 Future work**

Due to certain intrinsic limits in terms of project development time, budget and team size, a lot of things had to be omitted from the scope of this project. However, this leaves room for several augmentations/ improvements, expansions, and functionality add-ons.

First of all, at the moment the Project only accommodates one unit therefore the user base for the system will be extremely limited. In the future however, functionality could be expanded to include all major units and can be extended to operation and training areas.

## Glossary

API	Application Programming Interface
App	Application
AS	Assumption
Black box Testing	Testing emphasizes on the external behaviour of the software entity
C	Constraints
CO	Commanding Officer
NCO	Non-Commissioned Officer
VDRA	Vehicle Daily Running Account
Wpn	Weapon
App	Application
QM	Quarter Master
DBMS	Database Management System
DEP	Dependency
FRs	Functional Requirements
GUI	Graphical User Interface
IDE	Integrated Development Environment

iOS	Mobile Operating System created and developed by Apple
MCS	Military College of Signals
NFRs	Non Functional Requirements
NUST	National University of Science and Technology
OE	Operating Environment
OS	Operating System
Parse	Cloud Server
REQ	Requirement
SQL	Structured Query Language
SR	Safety Requirements
SRS	Software Requirements Specification
UD	User Documentation
UML	Unified Modelling Language
White Box Testing	Testing emphasizes on the internal behaviour of the software entity
Kote	Weapon Store room
MT	Mechanical Transport
MTEMS	Military Tactical Equipment Maintenance System



## Table 22 Glossary

### Bibliography

<https://www.coursera.org/>

<https://www.quora.org/>

<https://bytehost.com>

<https://www.w3schools.com>

## Turnitin Plagiarism Report:

### NUST - LMS Portal

Dashboard
Courses
NUST Plagiarism Detection Service
1
Plagiarism detection (June 2021)

---

My Submissions

Part 1
Part 2

Title	Start Date	Due Date	Post Date	Marks Available
Plagiarism detection (June 2021) - Part 1	31 May 2021 - 16:01	7 Jul 2021 - 16:01	7 Jul 2021 - 16:01	100

Refresh Submissions

	Submission Title	Turnitin Paper ID	Submitted	Similarity	Grade	Overall Grade	
View Digital Receipt	<a href="#">MTEMS Thesis Final Version</a>	1608222203	18/06/21, 02:50	10% <div style="width: 20px; height: 10px; background-color: #444; display: inline-block;"></div>	--	--	Submit Paper   --

### MTEMS Thesis Final Version

---

ORIGINALITY REPORT

---

# 10%

SIMILARITY INDEX

# 3%

INTERNET SOURCES

# 0%

PUBLICATIONS

# 9%

STUDENT PAPERS

---

PRIMARY SOURCES

---

1

**Submitted to Higher Education Commission Pakistan**

Student Paper

3%

---

2

**Submitted to UNITEC Institute of Technology**

Student Paper

2%

---

3

**Submitted to Engineers Australia**

Student Paper

1%

4	Submitted to 於2012-06-13提交至Higher Education Commission Pakistan Student Paper	<1 %
5	Submitted to Arab Open University Student Paper	<1 %
6	Submitted to Heriot-Watt University Student Paper	<1 %
7	Submitted to Universiti Malaysia Sarawak Student Paper	<1 %
8	Submitted to Gulf College Oman Student Paper	<1 %
9	backend.orbit.dtu.dk	

	Internet Source	<1 %
10	www.slideshare.net Internet Source	<1 %
11	Submitted to Southampton Solent University Student Paper	<1 %
12	Submitted to University of Greenwich Student Paper	<1 %
13	elib.uni-stuttgart.de Internet Source	<1 %
14	Submitted to University of Teesside Student Paper	<1 %

15	Submitted to Baze University Student Paper	<1 %
16	digitalcommons.calpoly.edu Internet Source	<1 %
17	www.cs.bilkent.edu.tr Internet Source	<1 %
18	Submitted to CSU, San Jose State University Student Paper	<1 %
19	resourcecenter.service-leadership.com Internet Source	<1 %
20	scholarworks.sjsu.edu Internet Source	<1 %

21	Submitted to Mississippi State University Student Paper	<1 %
22	Submitted to McMaster University Student Paper	<1 %
23	Submitted to Middlesex University Student Paper	<1 %
24	alfaisal.edu Internet Source	<1 %
25	spectrum.library.concordia.ca Internet Source	<1 %
26	core.ac.uk Internet Source	<1 %

---

27 [dspace.auk.edu.kw](https://dspace.auk.edu.kw) <1%  
Internet Source

---

28 [eprints.utar.edu.my](https://eprints.utar.edu.my) <1%  
Internet Source

---

29 [www.coursehero.com](https://www.coursehero.com) <1%  
Internet Source

---

---

Exclude quotes Off

Exclude matches Off

Exclude bibliography Off