

GLUCOM (NON-INVASIVE GLUCOMETER)



ASC Osama Saeed

Pc Mudassir Subhani

ASC Naeem Hussain

NC Haris Arshad

Supervisor

Assoc. Prof Dr. Muhammad Imran

Submitted to the Faculty of Department of Electrical Engineering, Military College of Signals,
National University of Sciences and Technology, Islamabad in partial fulfilment for the
requirements of a B.E. Degree in Electrical Engineering

June 2021

CERTIFICATE OF CORRECTIONS & APPROVAL

Certified that work contained in this thesis titled“ **Glucom (Non-Invasive Glucometer)**”, carried out by **PC Muddasir Subhani , ASC Osama Saeed, ASC Naeem Hussain & NC Harris Arshad** under the supervision of **Associate Professor Dr. Muhammad Imran** for partial fulfillment of Degree of Bachelors of Electrical Engineering, in Military College of Signals, National University of Sciences and Technology, Islamabad during the academic year 2019-2020 is correct and approved. The material that has been used from other sources it has been properly acknowledged / referred.

Approved by

Supervisor

Associate Professor Dr. Muhammad Imran

Date: 17th June,2021

DECLARATION

No portion of work presented in this thesis has been submitted in support of another award or qualification in either this institute or anywhere else.

Plagiarism Certificate (Turnitin Report)

This thesis has been checked for Plagiarism. Turnitin report endorsed by Supervisor is attached.

FYP Report

ORIGINALITY REPORT

11 %	11 %	2 %	4 %
SIMILARITY INDEX	INTERNET SOURCES	PUBLICATIONS	STUDENT PAPERS

PRIMARY SOURCES

1	www.swedishryk.edu.pk Internet Source	3 %
2	www.elektor.de Internet Source	1 %
3	www.ijltet.org Internet Source	1 %
4	Submitted to Ahlia University Student Paper	1 %
5	www.instructables.com Internet Source	1 %
6	dokumen.pub Internet Source	<1 %
7	Submitted to University of Nottingham Student Paper	<1 %
8	pr.hec.gov.pk Internet Source	<1 %
9	wordpress.nmsu.edu Internet Source	<1 %

10	collections.plymouth.ac.uk Internet Source	<1 %
11	dspace.auk.edu.kw Internet Source	<1 %
12	www.mdpi.com Internet Source	<1 %
13	Submitted to Engineers Australia Student Paper	<1 %
14	Submitted to Manchester Metropolitan University Student Paper	<1 %
15	dinshatech.blogspot.com Internet Source	<1 %
16	www.tandfonline.com Internet Source	<1 %
17	Submitted to Sheffield Hallam University Student Paper	<1 %
18	hdl.handle.net Internet Source	<1 %
19	ir.knust.edu.gh Internet Source	<1 %
20	scholarbank.nus.edu.sg Internet Source	<1 %
21	wrap.warwick.ac.uk	

Internet Source

<1 %

22 ir.uitm.edu.my
Internet Source

<1 %

23 www.forksoverknives.com
Internet Source

<1 %

24 open.library.ubc.ca
Internet Source

<1 %

25 www.make-a-difference.info
Internet Source

<1 %

26 Submitted to Leeds Beckett University
Student Paper

<1 %

27 repositorium.sdum.uminho.pt
Internet Source

<1 %

28 studentsrepo.um.edu.my
Internet Source

<1 %

29 www.ijptonline.com
Internet Source

<1 %

30 Wilbert Villena Gonzales, Ahmed Mobashsher,
Amin Abbosh. "The Progress of Glucose
Monitoring—A Review of Invasive to
Minimally and Non-Invasive Techniques,
Devices and Sensors", Sensors, 2019
Publication

<1 %

www.rss.chalmers.se

31

Internet Source

<1%

Exclude quotes Off
Exclude bibliography On

Exclude matches Off

Signature of Students

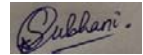

Muddasir Subhani (00000240934)

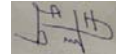

Osama Saeed (00000240930)



Naeem Hussain(00000240924)

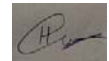

Harris Arshad(00000218944)

Signature of Supervisor

Associate Professor Dr. Muhammad Imran

Acknowledgements

I am thankful to my Creator Allah Subhana-Watala to have guided me throughout this work at every step and for every new thought which You setup in my mind to improve it. Indeed I could have done nothing without Your priceless help and guidance. Whosoever helped me throughout the course of my thesis, whether my parents or any other individual was Your will, so indeed none be worthy of praise but You.

I am profusely thankful to my beloved parents who raised me when I was not capable of walking and continued to support me throughout in every department of my life.

I would also like to express special thanks to my supervisor **Associate Professor Dr. Muhammad Imran** for his help throughout my thesis. I can safely say that I haven't learned any other engineering subject in such depth than the ones which he has taught.

Finally, I would like to express my gratitude to all the individuals who have rendered valuable assistance to my study.

*Dedicated to my exceptional parents and adored siblings whose
tremendous support and cooperation led me to this wonderful
accomplishment*

Abstract

Diabetes mellitus is a key state of apprehension for the current world with predictions of increase in patients in South Asia in near future. However, diabetes can be controlled by regular monitoring of glucose levels. The prevalent techniques are invasive and a source of discomfort for patients.

This thesis proposes a new technique of glucose measurement. Non-invasive glucometers using Near infrared radiation. A NIR ray of specified wavelength will be passed through skin. As a result, the reflected ray will be caught by sensor. The microcontroller will be used for analogue to digital conversion to determine the intensity level. The change in intensity is used to determine glucose level non invasively using linear regression.

The proposed method is not only efficient but very economical as well. This can be very beneficial for countries like Pakistan which spend considerable amounts on import of telemedicine technology.

Contents

Abstract	iii
List of Figures.....	xiii
CHAPTER 1: INTRODUCTION.....	1
1.1 Overview	1
1.2 Problem Statement.....	1
1.2.1 Categories of diabetes.....	2
1.2.2 Classification of glucose devices.....	4
1.3 Proposal:.....	6
1.3.1 Conversion overtone band.....	6
1.3.2 First overtone band	6
1.3.3 Second overtone band.....	6
1.4 Objectives:.....	7
CHAPTER 2: LITERATURE APPRAISAL.....	10
2.1 Overview	10
2.2 Literature Appraisal.....	10
CHAPTER 3: DESIGN AND DEVELOPMENT	13
3.1 Review.....	13
3.2 Electrical design	13
3.2.1 Components.....	13
3.3 Hardware design.....	19
3.3.1 Methodology.....	19
3.4 Software design	22
3.4.1 Arduino studio	22
3.4.2 MIT App Inventor	22
3.4.3 Methodology.....	23
CHAPTER 4 ANALYSIS AND EVALUATION.....	30
4.1 Overview	30
4.2 Illustration	30
4.4 Accuracy w.r.t market.....	32
CHAPTER 5 FUTURE WORK	34
5.1 Selection of appropriate wavelength.....	34

5.2 Sensitive receivers	34
5.3 Designing of transmitters with advanced wavelength	34
CHAPTER 6: CONCLUSION	36
6.1 Overview	36
6.2 Hindrances.....	36
6.3 Deliverables achieved.....	36
CHAPTER 7 REFERENCES	38
CHAPTER 8 APPENDICES.....	39
1.1 Appendix A.....	39
1.1.1 Synopsis.....	39

List of Figures

- Figure 1.1: Prediction of Increase of 55 percent in worldwide cases of World diabetes by 2035
- Figure 1.2: Formation of Imine from reaction of toluidine on aldehyde part of glucose
- Figure 3.1: ATmega32: 8-bit AVR Microcontroller
- Figure 3.2: HC 05 Bluetooth module
- Figure 3.3: 16x2 LCD display
- Figure 3.4: 2D Model of photodiode
- Figure 3.5: Schematic drawing
- Figure 3.6: Proteus design
- Figure 3.7: ARES design
- Figure 3.8: Pictures of basic components
- Figure 3.9 Design as per FICS IP
- Figure 3.10 Screenshot of the code for establishing connection between Bluetooth module and Android App
- Figure 3.11 Describing connection of Bluetooth device with app and its connection
- Figure 3.12 Screenshot for making the sensor in ON and OFF state and receive voltage level
- Figure 4.1 Table to create linear regression equation
- Figure 4.2 Hardware setup and result
- Figure 4.3 Linear regression analysis

CHAPTER 1: INTRODUCTION

CHAPTER 1: INTRODUCTION

IEEE is the biggest professional society for engineers which states the contribution towards betterment of humankind, as one of its aims. The common notion often held by an everyday person about the study of engineering is that it is a profession or course of study that revolves around rote memorization of complex theories and design of complicated applications. However the objective of IEEE sets a standard and signifies the importance of observing problems and using them to come up with innovative solutions, in order to cater to modern needs of humankind.

1.1 Overview

The current circumstances involving COVID-19 has exposed a big gap in medical care system for technology that permits minimum human contact.

Field of telemedicine has revolutionized the very perception and expanded the definition of healthcare. What first was thought of as an entity consisting of medicines and hospital equipment has now inculcated convenient and reliable technology. The inventions of convenient monitoring devices have transformed the way we treat diseases. However, because this field has its roots in the developed countries and the pharmaceutical industry being the most profitable business, telemedicine still lacks behind in medical devices that can be affordable in developing countries. These countries spend huge amounts of money in importing new technologies of telemedicine. Hence there is a dire need of economical innovation in the field of telemedicine.

1.2 Problem Statement

The diabetes mellitus is a serious cause of mortality and indisposition worldwide. It is a disease where the functioning of the hormone insulin is compromised. Diabetes is caused when pancreas is unable to produce insulin or failure of body to utilize it properly. It is produced via unique cells known as islets in pancreas. In basic terms, Insulin allows the glucose in our food to be entered into the bloodstream. The red blood cells use this glucose to convert it into energy, which in turn fuels our body. During increase in glucose amount in our body, the islet cells sense it and produce Insulin in return. It normalizes the blood glucose amounts which is necessary for suitable operating of body. However in diabetes, this simple but very important process is disturbed

which triggers the blood sugars to surge. [1] The levels vary over its usual limit of 90-140 mg/dl [2]

Diabetes has three main kinds: Type:1 diabetes, Type:2 diabetes, and gestational diabetes.

1.2.1 Categories of diabetes

1.2.1.1 Type 1 diabetes

The extremely severe kind of this disease is Type 1 diabetes.[1] According to International Diabetic Federation, Type 1 diabetes constitutes 10% of diabetic patients.

In this disease, the body comes under autoimmune attack. The islet cells that were responsible for producing insulin get attacked by the immune system. As a result, its function to produce insulin is severely hindered. This results in not enough Insulin being produced. With nothing to monitor it, the glucose levels in the blood alarmingly increases which then ultimately results in health complications. Moreover, the blood cells are unable to take in sugars and ultimately starve.[1]

1.2.1.2 Type 2 diabetes

Type:2 diabetes is the frequent form of diabetes. 90% of all diabetic cases are in fact Type 2 diabetic, according to International Diabetic Federation. It involves inability of the body to give a response to insulin. Unlike in Type 1, Type 2 produces a small amount of insulin. As discussed, the blood cells in the bloodstream require Insulin to allow sugar to be entered. And resultingly converted into energy However in Type 2, the cells do not respond to insulin. This is known as insulin resistance. Consequently, levels of blood sugars rise.

1.2.1.3 Gestational diabetes mellitus

Gestational diabetes mellitus is another type of diabetes where pregnant women experience hyperglycemia (high blood pressure). This puts the mother and the infant at a high risk for developing Type 2 diabetes later in life. Not only this, GDM is associated with pregnancy complications such as difficulty in labor hyperglycemia and delivering of infants with huge birth weight.

The population of people suffering from diabetes is escalating with a startling pace. Statistics estimate that the number of diabetic patients worldwide is 415 million and by 2040, the figures will increase to 642 million.[3] Hence if ignored, diabetes is a condition of concern for the modern world.

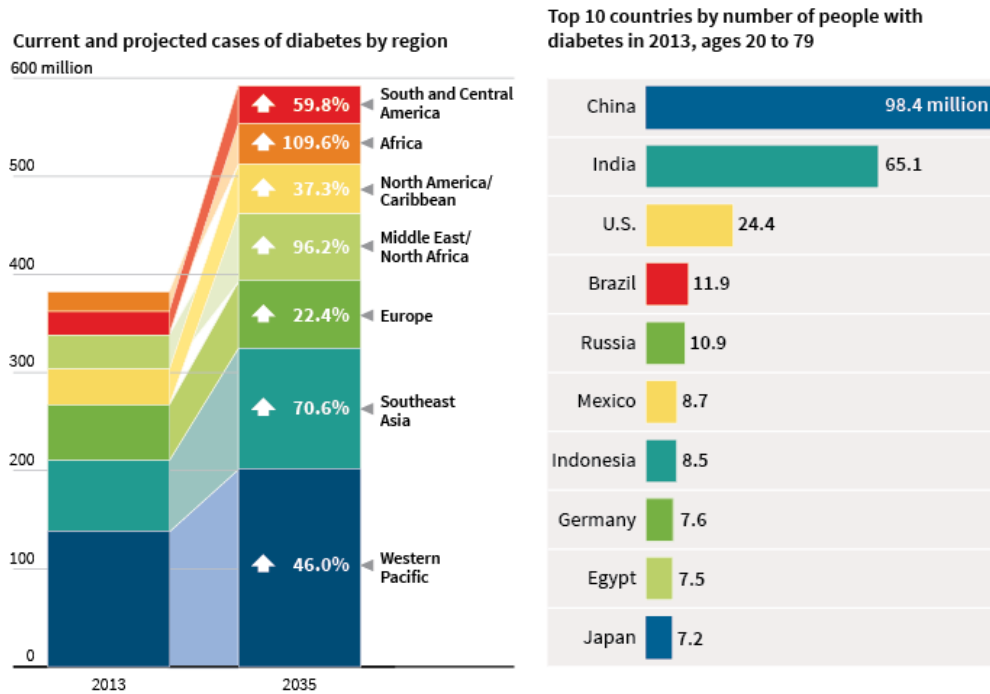

Figure 1.1: Prediction of Increase of 55 percent in worldwide cases of World diabetes by 2035

There is no cure for diabetes. Nevertheless, the situation can be progressed by assessing food intake, physical activity, and medical treatment. Hence, it is crucial to keep the blood glucose level under regular observation.[2]

Diabetic patient is more vulnerable to hyperglycemia. Hyperglycemia occurs when blood glucose level remains elevated. If not taken care of, it can seriously affect extremities, bones, kidneys and can cause coronary heart and cerebral vascular diseases. On the other hand, excessive use of blood sugar lowering medicines can cause hypoglycemia. Hypoglycemia results in blood sugar levels below 54 mg/die it is not treated immediately, it can lead to in complications such as coma, seizures, unconsciousness and even death.[4]

Keeping in mind all the consequences discussed above, it becomes essential for a person suffering from diabetes to scrutinize their blood sugars consistently.

1.2.2 Classification of glucose devices

Sensors that measure glucose levels are separated into following two types. This is based on the time taken by different glucose determination methods. [5]

1.2.2.1 Point sample glucose sensors

These sensors involve use of enzymes to calculate sugars. It is one of the initial approaches to evaluate glucose .It involves formation of an anil (imine) from a reaction between glucose and o-toluidine.

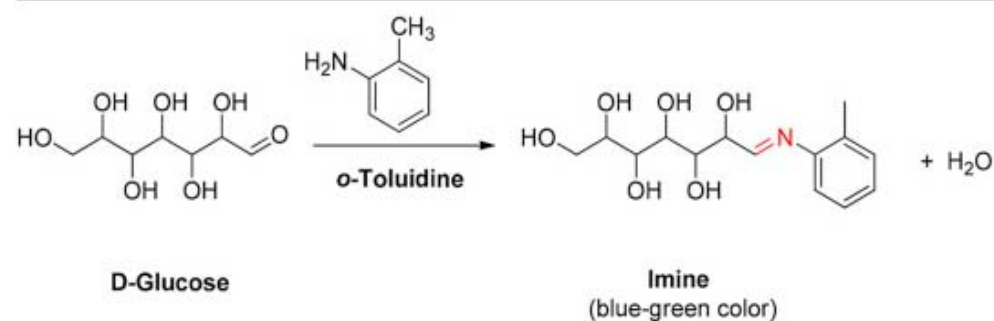

Figure 1.2: Formation of Imine from reaction of toluidine on aldehyde part of glucose

The imine shows highest absorption in visible zone of light spectrum. The intensity with which the resulting product absorbs is used to evaluate glucose. The main problem with this method was the fact that many other sugars in the blood tissue also contained aldehyde as their functional group. Even though the concentration of these monosaccharides is low, however the reaction of toluidine with these sugars would give erroneous results.[6]. Point sample sensors include conventional methods such as ones involving urine or finger piercing.[5]

1.2.2.2 Continuous glucose sensors

They provide comparatively more meticulous information. They are further split up into three classes:

1.2.2.2.1 Invasive

They include intravenous implantable and micro dialysis

1.2.2.2.2 Minimally invasive

Minimally invasive involves calculation of glucose quantity through body fluids (e.g. interstitial fluid) [7]. Microneedle is a constituent of this type.[5]

1.2.2.2.3 Noninvasive

As compared to the other two types, noninvasive procedures provide harmless substitutes. This technique uses radiation to access blood glucose.[7] They are further divided into two types:

1.2.2.2.3.1 Transdermal sensors

Transdermal sensors constitute of skin suction blister technique and impedance spectroscopy.[5]

1.2.2.2.3.2 Optical sensors

Optical sensors consist of mid-infrared spectroscopy, Near Infrared (NIR), fluorescence ,thermal infrared, and Ramen spectroscopy. [5]

There is a huge quantity of glucometers that use different techniques. However, there is still much to be desired in terms of quality and price. Especially for patients living in developing countries, the noninvasive techniques are often very expensive a result many are forced to resort to painful and uncomfortable invasive methods such as finger piercing glucometers and test strips . Moreover, these invasive methods are more likely to spread infectious diseases. Hence, it is safe to say that the current methods of glucose measurement has become source of discomfort to patients and there is a dire need to come up with a discrete non-invasive glucose measurement method which will allow them to monitor glucose level consistently. In short, a discrete non-invasive glucose measurement method.

Diabetic patients are required to keep a strict eye on the affect of diet and daily activities on their blood glucose levels. For this purpose, they might have to take several readings a week or in a day. However general methods for measuring blood glucose concentration available in the market are invasive in nature. For instance, the blood glucose monitoring devices involving finger pricking are very usual. Moreover, expenditure on test strip These techniques are not only aching

for the patient, but they are more prone to dispersing transmittable ailments. Techniques like test strip can become a burden on one's finances Hence there is dire need of effort required in development of noninvasive measuring devices that can help to monitor glucose levels in blood on a continuous basis.

1.3 Proposal:

Reliable and economical non-invasive glucometers are the answer to the mess of diabetes. The drawback with the existing techniques is their extreme expensiveness or erroneousness in measurement.

The proposed method in this thesis utilizes Near Infrared Radiation spectroscopy. This technique has gained popularity for its simplicity, safety and low expenditure.[2] It involves transmission of a light beam with a wavelength of 750-2500 nm. This beam is directed towards skin tissue with a thickness of 1-100 nm.[8] The reflected beam is used to determine the change in its intensity. This variation in intensity is used to evaluate biological parameters.

NIR range consists of the following bands:

1.3.1 Conversion overtone band

This band constitutes of wavelengths 2000-2500 nm

1.3.2 First overtone band

It consists of 1400-2000 nm wavelengths

1.3.3 Second overtone band

The wavelengths from 750-1400 nm are included in this. [2]

NIR light experiences partial absorption and scattering when it is directed towards the skin. This is because of its collision with chemical elements in our blood tissue which results in attenuation of signal. The light transport theory describes this attenuated signal through the following equation: [9]

$$I = I_0 e^{-\mu_{eff}d}$$

$$\mu_{eff} = f(\mu_a, \mu_s)$$

where I denote the intensity of the reflected signal, I_0 is the intensity of the incident signal. The optical path length is represented by d and μ_{eff} is the coefficient of attenuation. μ_a is the coefficient of absorption corresponding to displacement of water in tissue and μ_s is the scattering coefficient in relation with refractive index and diameter.[9] According to the equation, quantity of glucose and light intensity have a direct relationship. Surge in blood glucose results in decrease in μ_s and μ_a . This in return reduces d (optical path length) and increases the intensity of reflected beam of light [10] In simple words, higher value of intensity of attenuated signal will signify greater concentration of glucose in blood. In contrast. its lower value which will indicate lower amount of glucose.

Detectors can be used to measure the alterations in intensity of transmitted light when it reflects from the blood tissue.[9] In the case of NIR technique, the light can be projected on different body parts to determine level of glucose. These include buccae (cheek), antebrachium (forearm), finger, lobulus auriculae (earlobe), labia oris (lip) and lingua (tongue).[2]

Our approach also involves the design of a mobile Android application. At a time when mobile phone has revolutionized our communication, it becomes imperative to use the effective advantages of having a healthcare system based on telemedicine. Telemedicine allows a caretaker to take care of a patient without letting distance be a hindrance.[11] Health monitoring devices that use the technology of telemedicine are more helpful in exchanging feedback between a caretaker and patient [12]

Hence, our proposed solution consists of a reliable and handy noninvasive glucose monitoring device that solves the problem of discomfort, cost, and safety.

1.4 Objectives:

- Our objective is to prepare a consistent, precise and compatible non-invasive Glucose monitoring device that can economically replace the current invasive techniques.
- To employ NIR spectroscopy as the optical technique used to measure glucose.
- To improve signal quality by adding adequate alterations to the hardware.

- To add wireless functionality
- To interface it with an Android application

CHAPTER: 2

LITERATURE APPRAISAL

CHAPTER 2: LITERATURE APPRAISAL

2.1 Overview

As discussed in the prior chapter, NIR optical method is the technique under study in this paper. This is due to its cost effectiveness.

For effectively measuring glucose concentration, a specific wavelength from the three bands of NIR range had to be chosen. For that, a couple of research papers were studied that experimented with different wavelengths of NIR light and obtained respective RMSEP values.

2.2 Literature Appraisal

A satisfactory amount of literature on glucose measurement using NIR spectroscopy was found to be available. In 1997 *Mueller et.al.* used NIR light of wavelength between 800-1350 nm to measure glucose. They used a method called NIR diffuse reflectance spectra which consisted of a fiber optical measuring head, light source and a NIR spectrometer. The error was calculated in form of RMSEP which came out to be from 1.02 mmol/L to 1.88 mmol/L. In 1998 *Danzer et. al.* utilized the same intensities of 800-1350 nm through NIR diffuse reflectance spectra. The study obtained a RMSEP of 2.0 mmol/L by using middle finger as the test area. In 2004 *Araujo-Andrade et. al.* used the same NIR diffuse reflectance spectra and NIR light of wavelength 900-1700 nm. The similar technique involving NIR spectrometer, a source of light and fiber optical measuring head was used. The RMSEP was higher than 0.89 mmol/L with finger as the test area. The next year, *Xu et. al.* used a method called optical measurement condition reproduction technique. This method consisted of LED diodes, fiber probe, spectrometer, CCD camera, three-dimensional servo device and a brocket. The wavelengths used were from 1100 to 1800 nm to evaluate blood sugar through palm. The RMSEP ranged from 0.8 to 1.1 mmol/L [16] In 2010 **Guevara and Gonzalez et. al.** used wavelengths of 700-1000 nm of NIR along with impedance spectroscopy to measure glucose. The RMSEP achieved was 1.2488 mmol/L after testing in controlled humidity and temperature conditions on 10 healthy persons. The testing area selected was forearm. In 2013 *Srivastava et. al.* used 940 nm infrared light in the proposed noninvasive optical method. The light

was transmitted on the finger and the reflected signal was subjected to a special algorithm for detection of glucose. However, the results were not evaluated. In 2014 Pavithra *et. al.* proposed a system which used occlusion NIR spectroscopy. The system had two NIR sensors for measuring hemoglobin and glucose. The study was using a beam of 1000 nm for calculating glucose. The designed device also underwent experimentation on humans. In the same year of 2014, Yadav *et. al.* proposed a new method for noninvasive measurement of glucose levels. It used a NIR transmitter to transmit a wave of 940 nm wavelength. The results were evaluated through in vitro and in vivo experiments. In in vivo experiments, change in blood glucose level was determined for seven healthy persons before and after the meals. In vitro experiments showed that with surge in blood glucose concentration, there was decline in transmittance. In 2015 Guo *et. al.* proposed a new method for measuring blood glucose noninvasively. It measured readings from four different fingers. It was based on double artificial neural network analysis and NIR spectra of four different wavelengths of 820, 875, 945 and 1050 nm wavelengths. The average RMSE was 3.80 mg/Dl. In 2015 Tamilselvi and Ramkumar *et. al.* proposed a NIR **spectroscopy** system that used NIR light of 940 nm wavelength. It also used Global Positioning System to send location of user to a physician. However, the evaluation of technique was not carried out. In the same year, Pande and Joshi *et. al.* proposed that a transmitter of wavelength 1450 nm was more suitable for noninvasive determination of glucose. They showed this with a signal filtering circuit. In 2016 Bobade and Patil *et. al.* offered another technique for noninvasive technique. The study worked with NIR light of wavelength 940 nm. The design consisted of light passing through finger of patient and the transmitted light being measured before being processed with an algorithm. The result was displayed on LCD and sent to an Android application. Bahareh *et. al.* in 2018 **proposed** a method for measuring blood glucose noninvasively. They also designed a **mobile application** for communication with the optical sensor and display of results.

Our design involves a device that measures NIR voltages and uses an Android application to determine the corresponding glucose levels.

CHAPTER: 3

DESIGN AND DEVELOPMENT

CHAPTER 3: DESIGN AND DEVELOPMENT

3.1 Review

Design of noninvasive glucometer was not for the faint hearted. The process was subject to many hurdles. One of them was signal correction. The incoming light consisted of a lot of noise and attenuation. Therefore, it was passed through a noise removal circuit. Secondly, we used Atmega 32 microcontroller which could be programmed through a specific software. We learned the Atmel studio coding and successfully ran our algorithm. Thirdly, we had to go through extensive literature study to select the appropriate wavelength. The results were tested through two type of experiments: in vitro and in vivo.

3.2 Electrical design

3.2.1 Components

Our system involves transmission of NIR signal and a receiver which will receive the attenuated signal. This signal will undergo filtration through Panda and Joshi circuit and analogue to digital conversion. The microcontroller will convert the sensor readings to voltage values. The LCD will display these values.

Our design of Noninvasive glucometer used the following components:

3.2.1.1 Arduino Nano with AT-Mega 32

The Arduino Nano is a small, complete, and breadboard-friendly board based on the ATmega328 (Arduino Nano 3.x). It has more or less the same functionality of the Arduino Duemilanove, but in a different package. It lacks only a DC power jack, and works with a Mini-B USB cable instead of a standard one.

The brains of this project are the microcontroller. ATmega32 of Arduino Nano is an energy intensive CMOS microcontroller of 8 bits, which is built on AVR improved RISC architecture. It

attains outputs reaching 1 MIPS per MHz ,by executing potent commands in a sole clock cycle. This allows the optimization of power expenditure in opposition to processing rate.

The reason why we have chosen microcontroller Atmega32, is because it has a lot of desirable features. For instance, it provides enough In-System Programmable Flash Program memory with 32K bytes. This comes along with aptitude of Read-While-Write . Secondly, it has general purpose I/O lines and interrupts with an amount of 32.

A good set of commands in conjunction with 32 number of general-purpose working registers is combined in AVR hub. It also involves retrieval of two self-regulating registers in a lone command implemented in single clock cycle due to direct connection of these 32 registers to Arithmetic Logic Unit (ALU). The resultant design is further code accomplished. It can achieve ten times faster throughputs as compared to conformist CISC microcontrollers.[25] Because of its desirable features,Atmega32 is suitable for use in mobile embedded system where it requires minimum interference from humans [26]

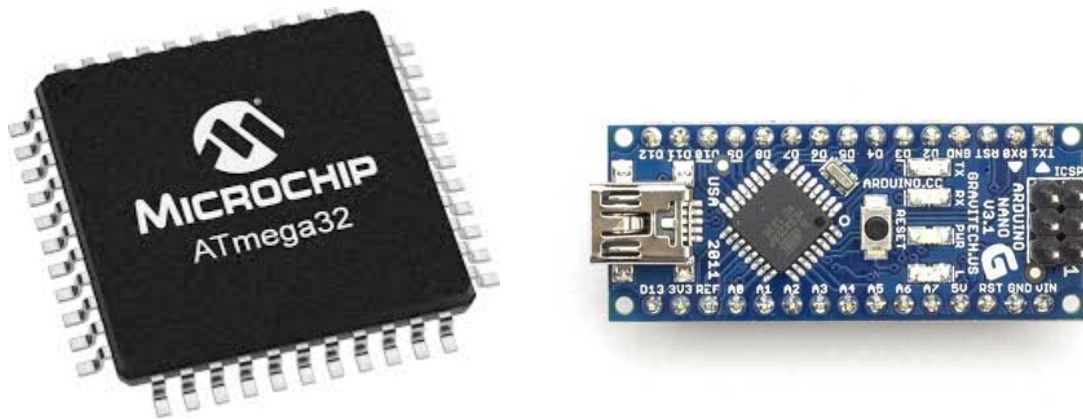

Figure 3.1 ATmega 32: 8-bit AVR Microcontroller & Arduino uno

In this project, the microcontroller must carry out analogue to digital conversion. It controls the receivers and transmitters through its D pins. On its A0 pin, it receives the filtered signal which is converted to a voltage value. The microcontroller then sends these values to the Android application.

3.2.1.2 Bluetooth module HC-05

This module exists to be a sought-after component in implementation of wireless functions in most projects. It operates in two mode: Data mode and Command mode. In data mode, it communicates with other Bluetooth devices to send and receive data. In the AT Command mode, it allows the user to make changes in its default settings.



Figure 3.2 HC 05 Bluetooth module

Our project required transmission of sensor readings to be sent to Android application for determination of glucose levels. In order to make this process reliable, adding two-way wireless functionality was the best option. For this purpose, HC-05 Bluetooth module was used in our project to send voltage values from the microcontroller to the Android application.[25]

3.2.1.3 LCD Display

Embedded system commonly use 16x2 LCD displays. As the name suggests it has 16 columns and 2 rows. This means it can display a total of $(16 \times 2 = 32)$ 32 characters and 1280 pixels. In order to easily interface these pixels, it requires an Interface IC to receive commands and data, apply necessary procedures and display the data accordingly. The IC used in the case of 16x2 LCD display is HD44780 which is mounted on the rear end of LCD.



Figure 3.3 16x2 LCD display

Our main objective was to come up with an affordable instrument therefore 16x2 LCD display was the best choice for display. It is reasonable, convenient and programmer friendly.[27]

3.2.1.4 Photodiodes

Photodiode is a very common name in embedded systems. It is used to detect light and produce a proportional amount of current. It has an anode and a cathode which are connected in inverse polarity. [28]

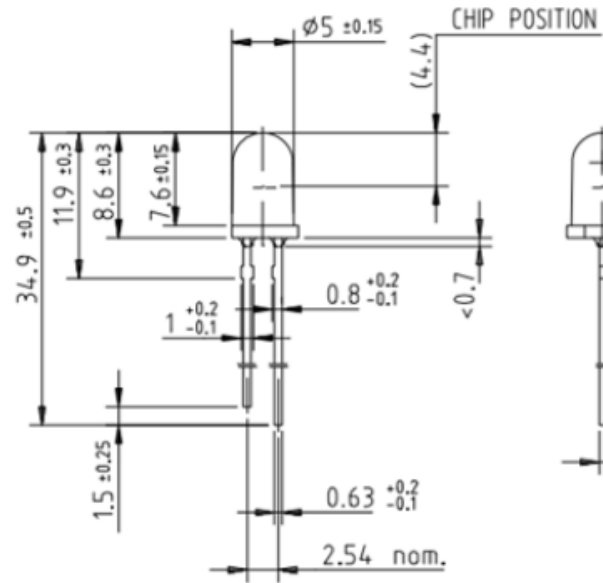

Figure 3.4 2D model of a photodiode.

No matter how basic it sounds, its use should not be underestimated. It can be used with an IR LED for detection of objects. In our case, we have used it to detect the attenuated NIR signal coming from the finger.

3.2.1.5 Android application

An Android product is devised for the interaction between sensor and smartphone user interface through the Bluetooth module. The information from the sensors is then received by the application where it is managed and recorded . The Android app's working is shown as:

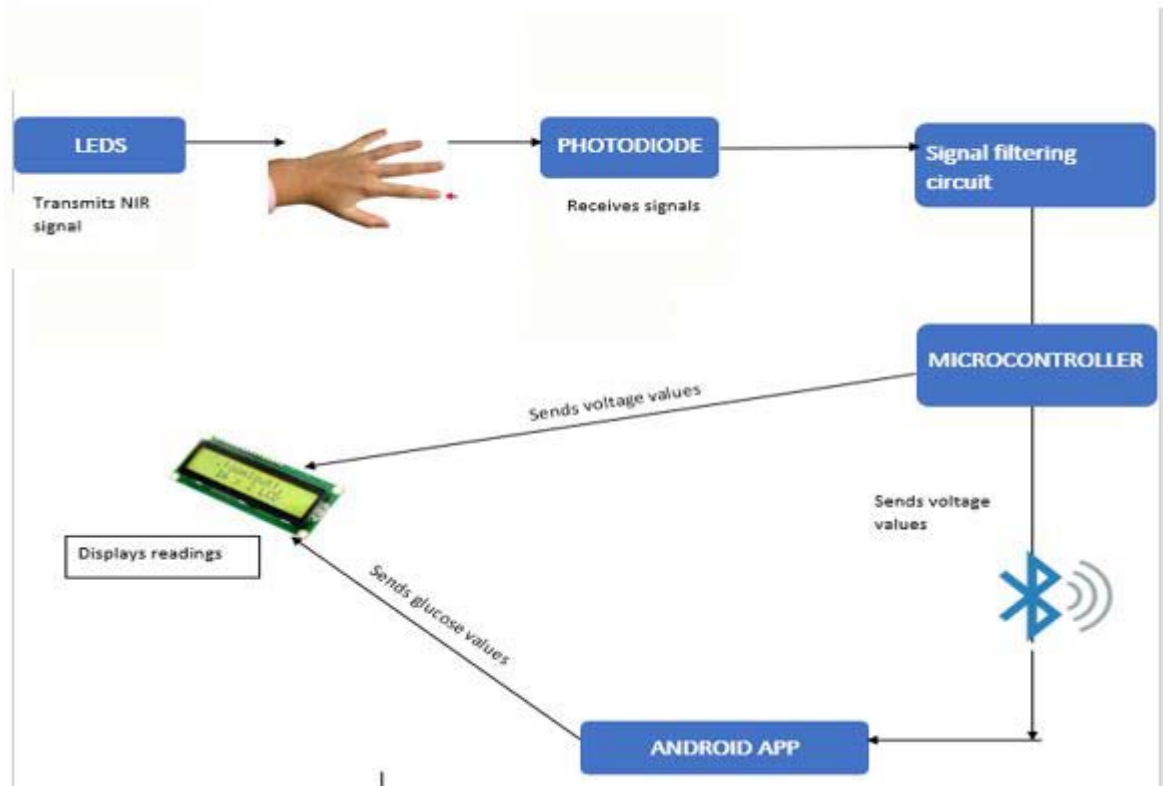

Figure 3.5 Schematic drawing

The other components used are:

- Voltage regulator LF33CV
- Voltage regulator L7805CV
- Amplifier LM 324
- Transistor 2N3904
- Resistors of different resistances of
- Capacitors of 1u,100 nF,0.1 u.

3.3 Hardware design

The above-mentioned components were tested on Proteus in order to design its circuit and the obtained circuit was used for hardware implementation.

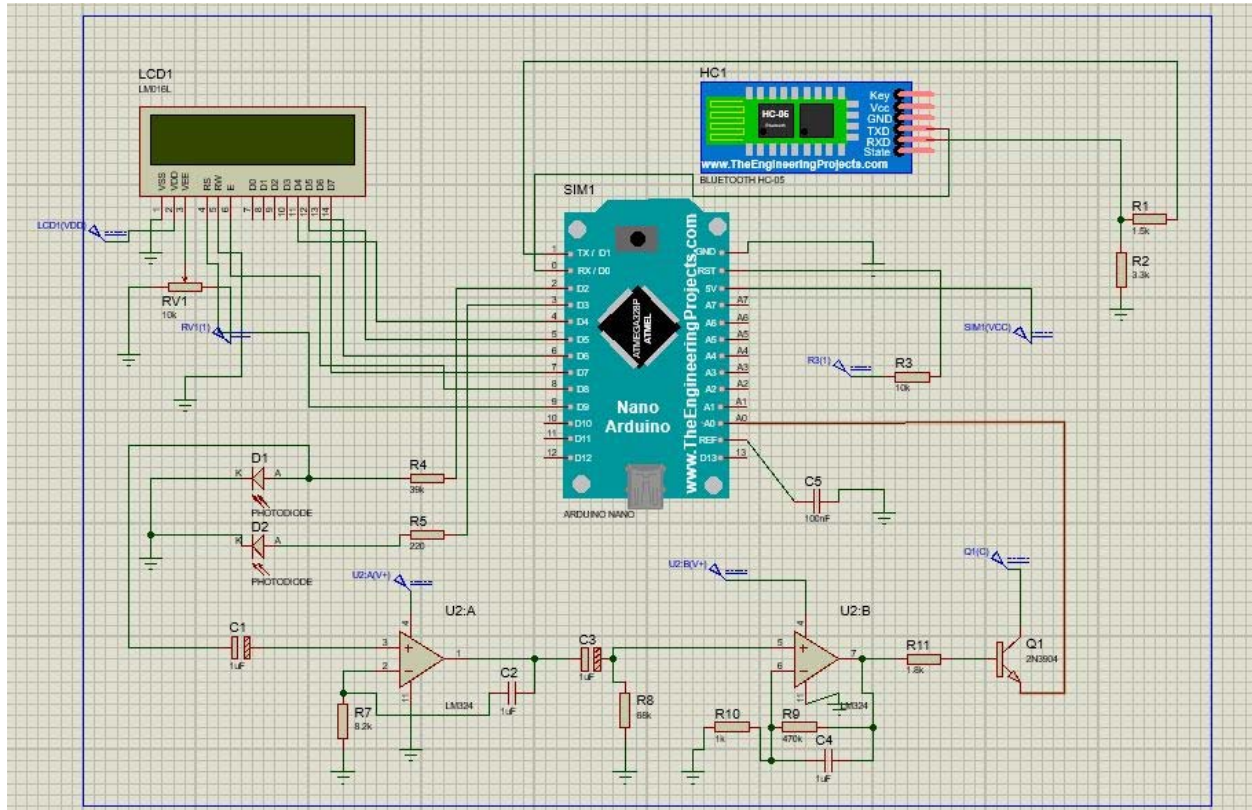

Figure 3.6 Proteus design

3.3.1 Methodology

- Our design involves the technique of NIR spectroscopy to measure glucose.
- NIR wavelengths of 940 is used to measure glucose [24]
- The AVR ATmega32 microcontroller is utilized to monitor the transmitters and the receiver which are associated to its Port D pins.
- The Pande and Joshi [22] circuitry is included for sorting, intensification, and signal isolation.

- Microcontroller transforms the input signal to a voltage value and brings out the managing.
- The voltages are displayed on the LCD.
- These results are sent through Bluetooth module to the Android app.

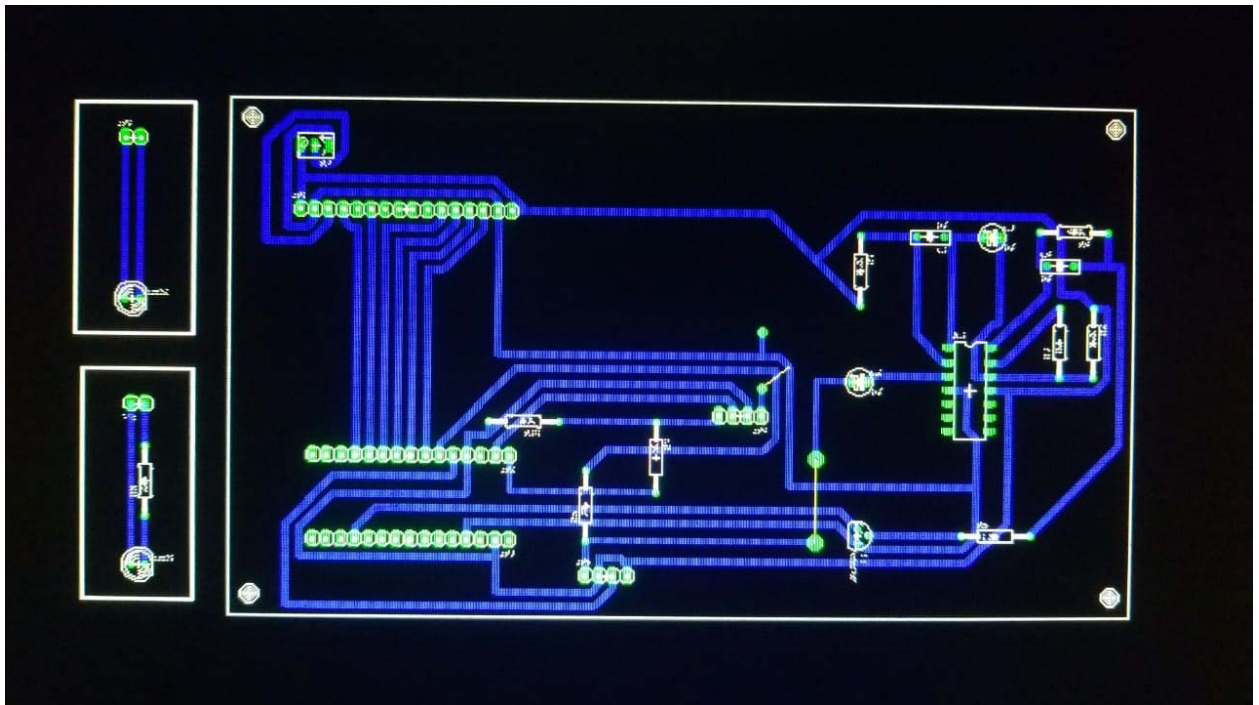
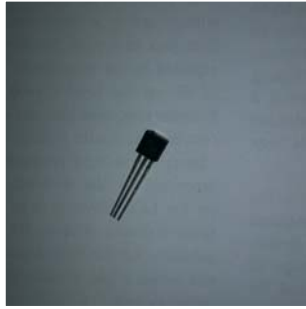

Figure 3.7 ARES design

Some of the components used are:

2N3904 Transistor



Resistors



Voltage Regulator L7805CV



LM 324 Amplifier



100 Nf Capacitor



1uF Capacitor

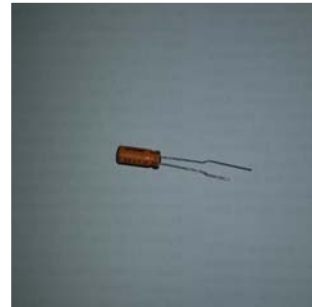

0.1 uF Capacitor



Figure 2.8 Pictures of basic components

3.4 Software design

Following software were used for designing two code books:

- Arduino studio (pass voltages to the LCD and measure Glucose Level)
- MIT App Inventor (Passing voltages to the android app)

3.4.1 Arduino studio

Arduino Studio is a software application used to aid in integration, development and debugging of Atmel ARM and AVR microcontrollers applications.

3.4.1.1 Necessities for installing Atmel Studio 7.0

- 1 GB RAM for x86
- GB RAM for x64
- Processor of 1.6 Hz or higher
- Hard disk space of 6GB

3.4.2 MIT App Inventor

MIT App inventor allows programmers to integrate.... different parts of writing a program into a single application for Android development.

3.4.2.1 Necessities for Installing Arduino studio

- Search online for Android Studio executable.
- Click the zip file to download it.

- When the downloading has been complete, choose the path for installation.
- If the software has not been installed before on the system, select “Don’t import settings”
- The program will look for the required SDK components in the system.
- After it is successful, a dialogue box will open
- Select the type of setup. “Standard” is recommended.
- Select the theme
- Download the SDK components
- After triumphant configuration, Android Studio will be equipped to use. [30]

3.4.3 Methodology

The algorithm was designed while keeping the following pseudocode objectives in mind:

- To determine the intensity of the attenuated signal after it passed through the test area (finger).
- To find the voltage of the detected signal by converting intensity into voltage value through the help of formulae.
- To convert the formulated value into a finite value of voltage.
- To develop an Android app for:
 - ❖ Finding corresponding glucose value (regression analysis)
 - ❖ Improving communication between a patient and a doctor.

3.4.3.1 Atmega32 coding in Arduino Studio

Atmel studio was used here to tackle the first three objectives. The algorithm here is an example of a code for switching the LEDs. Moreover, it is receiving the input signal at serial pins and converting it into a digital voltage value. This is then sent to Bluetooth module

```
#include <LiquidCrystal.h>

const int rs = 9, en = 8, d4 = 7, d5 = 6, d6 = 5, d7 = 4;
LiquidCrystal lcd(rs, en, d4, d5, d6, d7);
int voltageLevel;
int sugarLevel=80;
void setup() {
  pinMode(2,OUTPUT);
  pinMode(3,OUTPUT); //define pin 3 as output
  Serial.begin(9600); //Start Serial Communication (bluetooth)
  lcd.begin(16, 2);
}

void loop() {
  if(Serial.available()){ //check if the module is receiving anything via bluetooth
    lcd.clear();
    lcd.setCursor(0, 0);
    int recebe = Serial.read();
    Serial.println(recebe); //show on Serial Monitor the value received via bluetooth
    if(recebe-48 == 1){
      digitalWrite(2,HIGH);
      digitalWrite(3,HIGH);
    }
    else if(recebe-48 == 0){ //if the received value is 2...
      digitalWrite(2,LOW);
```

```

    digitalWrite(3,LOW);
}

voltageLevel = analogRead(A0);

//Serial.println(voltageLevel);
//lcd.print("V: ");
//lcd.print(voltageLevel);

//lcd.setCursor(8, 0);
// calculate you sugar level after calibration then store this value to sugarLevel variable
and comment next line
sugarLevel = 0.51*(voltageLevel-13.75);
lcd.print("G: ");
lcd.print(sugarLevel);
  lcd.print("mm/dL");

lcd.setCursor(0, 1);
if(sugarLevel<140)
{
  lcd.print("Normal");
}
else if(sugarLevel>140 && sugarLevel<199 )
{
  lcd.print("Pre Diabetese");}
else
{
  lcd.print("Diabetic");}
delay(100);
}

```

3.4.3.2 Android application

The following algorithm is the most important part of the whole design. The pseudocode involves defining libraries and receiving voltage values from microcontroller through serial port and show the voltage level received from the microcontroller.

3.4.3.2.1 Pseudocode

- In the code displayed below, the Bluetooth client is added in order to scan the nearby devices to take data.

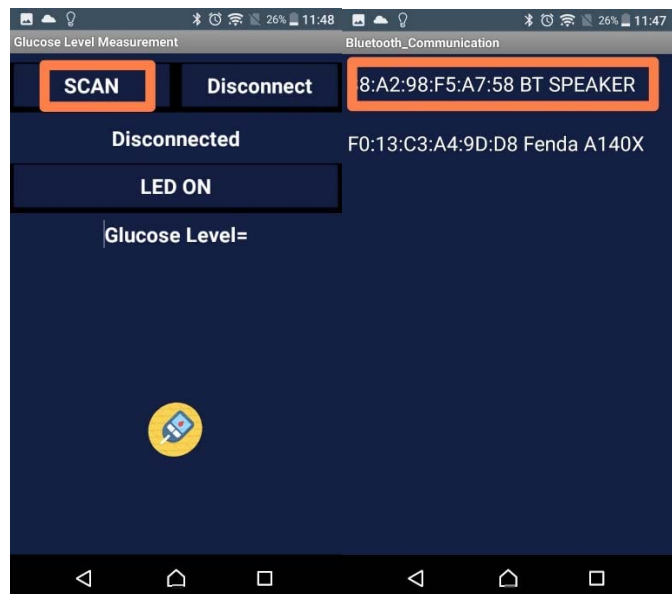

```
when ListPicker1 . BeforePicking
do set ListPicker1 . Elements to BluetoothClient1 . AddressesAndNames
```

Figure 3.10 Screenshot of the code for scanning nearby Bluetooth devices by Androip App

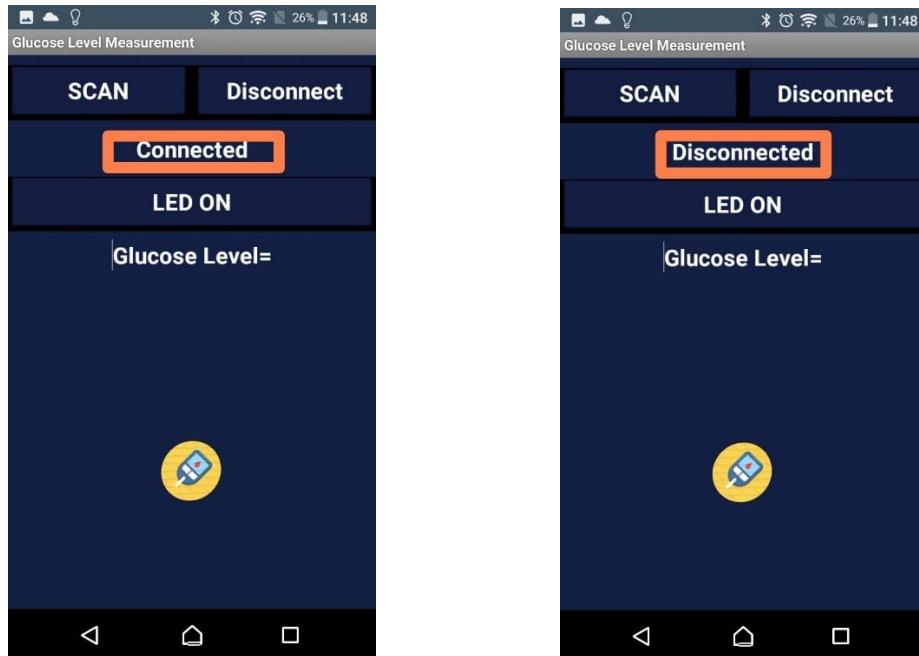

```

when ListPicker1 .AfterPicking
do
  if call BluetoothClient1 .Connect
     address ListPicker1 . Selection
  then set Label1 . Text to "Connected"

when disconnect .Click
do
  call BluetoothClient1 .Disconnect
  set Label1 . Text to "Disconnected"

```

Figure 3.11 Describing connection of Bluetooth device with app and its disconnection

- First of all when then showing Bluetooth is clicked the app will be connected to the device and when it disconnect button is pressed the the device will be disconnected.

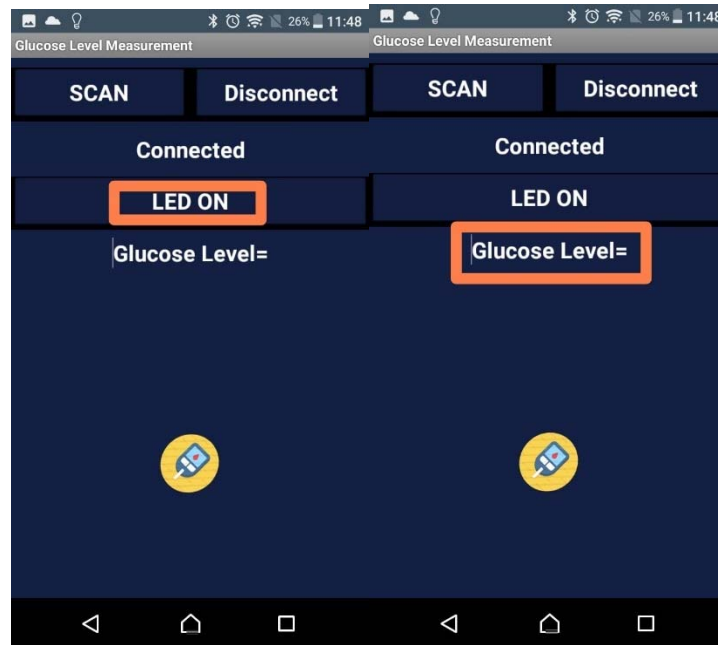

```

when led_on . Click
do
  if BluetoothClient1 . IsConnected
  then
    if led_on . Text = "LED ON"
    then
      call BluetoothClient1 . SendText
      text "1"
      set led_on . Text to "LED OFF"
    else if led_on . Text = "LED OFF"
    then
      call BluetoothClient1 . SendText
      text "0"
      set led_on . Text to "LED ON"
  
```

Figure 3.12 Screenshot for making the sensor in ON and OFF state and receive voltage level

- When LED on button is pressed it means the 1 is sent to Arduino which will make the sensor on state and to get voltage and receive voltage here.
- When LED Off button is pressed it means the 0 is sent to Arduino which will make the sensor Off state and no bytes will be received.

CHAPTER: 4

ANALYSIS AND EVALUATION

CHAPTER 4 ANALYSIS AND EVALUATION

4.1 Overview

Even though humans have been battling diabetes for awhile, there has been not much result in finding its cure. However there has been use of different methods to monitor it. Glucotech is one of them. It uses the NIR spectroscopy and optical method to monitor blood glucose levels. It is cheap, efficient and reliable.

4.2 Illustration

To Obtain polynomial regression equation, 16 diabetic and non Diabetic individuals including both genders are considered. Glucose level of these individuals is measured using invasive method and at the same time the analog voltage corresponding to their glucose level is also measured using the proposed hardware setup as shown in figure 4 and the readings are tabulated in table1. .

Sr.No	Glucose Concentration(mm/dl)	Analog Voltage(mV)	Sr.No	Glucose Concentration(mm/dl)	Analog Voltage(mV)
1	88	170	9	125	241.25
2	99	191.7	10	134	255.94
3	101	194.93	11	141	272.13
4	108	208.44	12	144	277.92
5	111	214.23	13	156	301.8
6	112	216.6	14	165	318.45
7	113	218.9	15	212	409.16
8	124	239.32	16	219	422.67

Table 4.1. Data to create Linear Regression Equation

The analog voltage measured at analog pin A0 of Arduino due microcontroller and the corresponding glucose concentration measured by the invasive method are plotted on a graph and shown in figure 4.3. The polynomial equation relating the analog voltage and the glucose level is computed by using regression tool and shown below. $x = 0.51*(y-13.75)$

where x and y are glucose level (mg/dl) and analog voltage (mV) and respectively.



Figure 4.2 Hardware setup and result

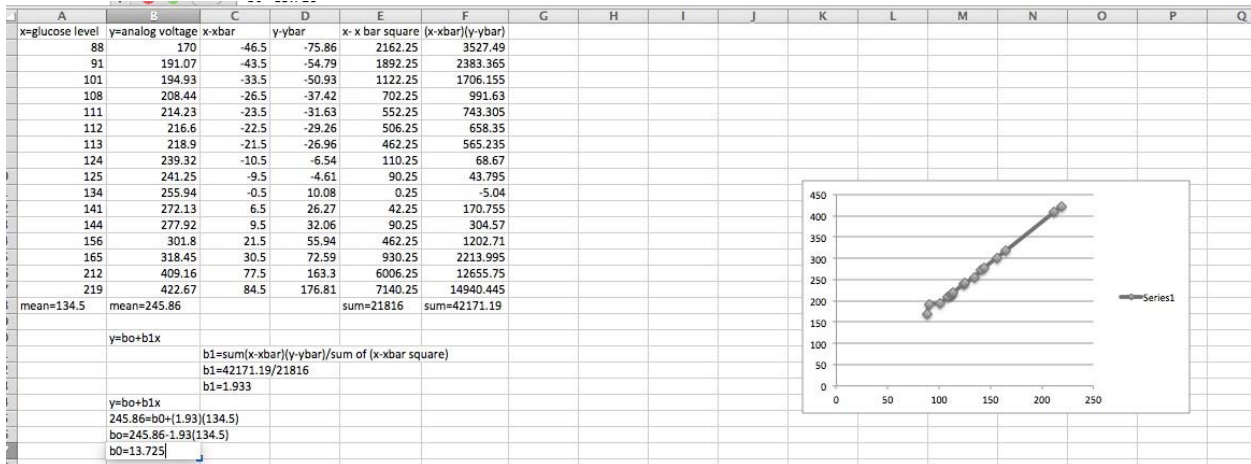

Figure 4.3 Linear regression analysis

4.4 Accuracy w.r.t market

According to ISO Standard, 95% of the blood glucose results have a Margin of Error within $\pm 15\%$ at glucose concentrations of 100 mg/dL[31]

TABLE II OTHER NON-INVASIVE TECHNIQUES AND RESULT ANALYSIS		
Technique	Principle of determination	Result and analysis
NIR spectroscopy	Absorption or emission data in 0.7-2.5 μ m region was compared to known data for BG. Test sites were ear lobes, finger webs, finger cuticles, forearm skin and lip mucosa (λ -1000nm to 2500nm).	NIR diffuse reflectance performed on fingers and cuticles. Good correlation with BG, 90 per cent of predictions are clinically acceptable.

Figure 4.4 Table of noninvasive procedures and analysis of results

CHAPTER: 5

FUTURE WORK

CHAPTER 5 FUTURE WORK

Glucotech is an innovative idea in the domain of telemedicine striving to combat diabetes by designing a reliable and cost-effective instrument for measuring blood glucose concentration.

5.1 Selection of appropriate wavelength

The selected wavelength holds great importance in blood glucose measurement. This is because there are also water molecules and other molecules which often get affected by the transmitted signal and result in erroneous measurement. Hence more research is required in finding a specific wavelength which could effectively penetrate through skin, without getting attenuated by water and other surrounding molecules present in our finger.

5.2 Sensitive receivers

Further improvements can be achieved by using more sensitive receivers that can detect the transmitted NIR signal efficiently.

5.3 Designing of transmitters with advanced wavelength

Innovation in design of transmitters will yield more satisfactory results. Experimentation for finding more suitable wavelengths might require more advanced transmitters.

CHAPTER 6:

CONCLUSION

CHAPTER 6: CONCLUSION

6.1 Overview

The rationale behind this project was to design a reliable non-invasive glucose measuring device capable of solving the problem of invasive and painful blood glucose measuring methods, using NIR Spectroscopy. Glucotech will be one in a kind device in the pharmaceutical market. This is because it has a suitable competitive advantage of being cost effective and safe at the same time. It will permit diabetic patients to reliably measure their blood glucose level several times a day.KJL;00

6.2 Hindrances

Due to COVID pandemic, we experienced nationwide lockdown. As a result, the process of hardware fabrication had to come to a big halt. LEDs of 1650 nm, which were the main component, could not be delivered to us due to lockdown. This stalled the process of integrating our software block with hardware.

6.3 Deliverables achieved

The circuit of the design is completed successfully. Similarly, the software code is fabricated as well. The application is fully functional. Moreover, integration of hardware part with the software is complete.

CHAPTER 7:

REFERENCES

- [1] *What Is Diabetes?* www.diabetesresearch.org/what-is-diabetes.
- [2] Yadav J, Rani A, Singh V, Murari BM, Near-infrared LED based non-invasive blood glucose sensor.2014 International Conference on Signal Processing and Integrated Networks (SPIN). Noida, India: IEEE; 2014.
- [3] Written by Editor Updated on 15th January 2019, & Editor. (2020, February 13). Diabetes Prevalence. Retrieved from <https://www.diabetes.co.uk/diabetes-prevalence.html>
- [4] “What Is the Difference Between Hyperglycemia and Hypoglycemia?” *VisionAware*, 25 June 2020, visionaware.org/your-eye-condition/diabetic-retinopathy/hyperglycemia-and-hypoglycemia/.
- [5] Oliver NS, Toumazou C, Cass AE, Johnston DG. Glucose sensors :A review of current and emerging technology.*Diabet Merd* 2009;26:197-210.
- [6] Wang, Hui-Chen, and An-Rong Lee. “Recent Developments in Blood Glucose Sensors.” *Journal of Food and Drug Analysis*, vol. 23, no. 2, 2015, pp. 191–200., doi:10.1016/j.jfda.2014.12.001.
- [7] Villena Gonzales, W.; Mobashsher, A.T.; Abbosh, A. The Progress of Glucose Monitoring—A Review of Invasive to Minimally and Non-Invasive Techniques, Devices and Sensors. *Sensors* 2019, 19, 800.
- [8] Vashist SK. Non-invasive glucose monitoring technology in diabetes management: A review. *Anal Chim Acta*. 2012;750:16–27.
- [9] Tura A, Maran A, Pacini G. Non-invasive glucose monitoring: Assessment of technologies and devices according to quantitative criteria. *Diabetes Res Clin Pract*. 2007;77:16–40.
- [10] Govada A, Renumadhavi C, Ramesh K. Non-invasive blood glucose measurement. *Int J Adv Res Comput Commun Eng*. 2014;3:5122–5.
- [11] Ng H, Sim M, Tan CM, Wong C. Wireless technologies for telemedicine. *BT Technol J*. 2006;24:130–7.
- [12] conditions reproduction technique. *Optics Lasers Eng* 2005; 43:1096-106.

CHAPTER 8 APPENDICES

1.1 Appendix A

1.1.1 Synopsis

Extended Title: Non-Invasive Glucometer for blood glucose analysis

Brief Description of The Project / Thesis with Salient Specifications:

The project is inspired by the idea of contribution to the thriving field of telemedicine in Pakistan. Our project mainly aims at coming up with an economical solution to the use of painful and expensive techniques like strip testing for regular glucose testing of diabetic patients. It'll employ properties of optical signalling techniques to detect the level of blood glucose using a sensor embedded in a handy and compatible device. Testing area will be finger or any thin skin part like ear lobe etc. The sensor will be interfaced with microcontroller which will be programmed to apply regression analysis on the incoming attenuated IR signals values to compare it with existing table of established values. The result will be based on the value of nearest precision. Necessary analogue to digital conversion techniques will be employed to get easily readable values. An easy friendly display will be used to show values at run time. Also, there is an idea to develop a remote analysis GUI for feeding of results to distant database/user. The technique majorly intended to be employed, is Near Infrared Spectroscopy. The advantages of this technique are well acknowledged based on its accuracy and economical nature. Moreover, further techniques which are being worked upon by global science community are studied and will be considered for enhancing the result accuracy.

Scope of Work:

Telemedicine.

Use of NIR spectroscopy for glucose levels measurement.

Academic Objectives:

- Improving skills in design/development of useful hardware.
- Improving programming skills.
- Using optical technology.
- Learning and improving skills in signalling techniques.
- Using result formation and analysis techniques.
- Getting accustomed with different engineering software programs.
- Observing the scope of telemedicine

Application / End Goal Objectives:

Preparing an indigenous, economic and reliable non-invasive glucose measuring device for diabetic patients.

Project Development:

The progress of project, in terms of one of the working modules has been very satisfactory. The circuit design of the project has been completed. Moreover, the code required for software development has been written. Similarly, the relation between incoming attenuated IR signals and the corresponding glucose levels has been determined in the form of regression tables. These tables will be used by the device to apply regression analysis and determine the glucose level of the patient. At the same time, research on the availability of some of the hardware components has been done as well. Keeping the scope of this project in mind, initial strategies to showcase it on different competitive platforms, has been discussed as well.

Material Resources Required:

- Microcontroller (Arduino)
- Optical Sensors (mainly infrared/near infrared)
- Photo diode & LED sensors
- Analog to Digital Converters
- Bluetooth/WIFI module
- LCD display

No of Students Required: 04

Group Members:

- **PC Muddasir Subhani**
- **ASC Osama Saeed**
- **ASC Naeem Hussain**
- **NC Harris Arshad**

Special Skills Required:

- Use of sensor hardware
- Use of microcontroller programming
- Interface of sensors with ADCs and microcontroller
- Data analysis and comparison
- Interface with display& remote result base like LCD/ mobile app etc.